



# AXIL/EQUITHERM

Unit heaters / Destratification fans



WATER



 **4 - 20 kW**  
 **12 - 105 kW**  
 **1600 - 9100 m<sup>3</sup>/h**

# AXIL<sub>(A)</sub> 4<sub>(B)</sub> 02<sub>(C)</sub> 4<sub>(D)</sub>

(A) **AXIL** = Hot water - **AXIL F** = Hot/chilled water - **AXIL V** = High temperature water/steam - **AXIL Z** = Electrical heater - **EQUITHERM** = Destratifier  
 (B) Cabinet size - **4** = 526 - **5** = 636 - **6** = 743 - **9** = 1011  
 (C) **AXIL/AXIL F/AXIL V** = Number of rows - 2R, 3R, 4R - **AXIL Z** = Electrical heater capacity 14kW/24kW/39kW - **EQUITHERM** = 4-pole or 6-pole motor  
 (D) **AXIL/AXIL F/AXIL V** - 4 = 4/6-pole motor - 6 = 6/8-pole motor = - **AXIL Z** - R = control power fitted on (for thermostat control)

## AXIL

Heating only: Hot water maximum 120°C / 16bars  
 Airflow : 2000 to 9500 m<sup>3</sup>/h  
 Heating capacity (Air 18°C - Water 90/70°C): 12 to 96 kW  
 4 Sizes - 4/5/6/9

## AXIL F

Cooling and Heating:  
 Hot water maximum 120°C / 16 bars  
 Minimum Chilled water inlet 7°C  
 Airflow : 2000 to 9500 m<sup>3</sup>/h  
 Cooling capacity (Air 26°C/55% - Water 7/12°C) : 4 to 22,4 kW  
 4 Sizes - 4/5/6/9

## AXIL V

Heating only:  
 Hot water, Superheated water or Steam  
 Maximum 210°C / 20 bars  
 Airflow : 2100 to 9200 m<sup>3</sup>/h  
 Heating capacity (Air 18°C - Steam 15bars) : 31 to 151 kW  
 4 Sizes - 4/5/6/9

## AXIL Z

Heating (electrical heater)  
 Airflow : 1560 to 4790 m<sup>3</sup>/h  
 Heating capacity : 14 / 24 / 39 kW  
 3 Sizes - 4/5/6

## EQUITHERM

Ventilation only  
 Airflow : 1700 to 13000 m<sup>3</sup>/h  
 4 Sizes - 4/5/6/9



AXIL		AXIL (HOT WATER)				AXIL F (HOT/CHILLED WATER)				AXIL V (HIGH TEMPERATURE WATER/STEAM)			
		4	5	6	9	4	5	6	9	4	5	6	9
A	mm	526	636	743	1011	526	636	743	1011	526	636	743	1011
B		526	636	743	1011	537	647	754	1022	526	636	743	1011
C		468	468	468	576	468	468	468	576	468	468	468	576
D		69	69	60	92	69	69	60	92	69	69	60	92
E*		-	-	-	-	542	650	758	1026	-	-	-	-
F*		-	-	-	-	450	450	450	450	-	-	-	-
<b>Weight of standard units</b>													
2R	kg	22	25	34	81	22	25	34	81	22	25	34	81
3R		23	28	39	90	23	28	39	90	23	28	39	90
4R		25	32	45	100	25	32	45	100	25	32	45	100
Steam		-	-	-	-	-	-	-	-	30	38	51	92

\* Drain pan only available on chilled water version (AXIL F).

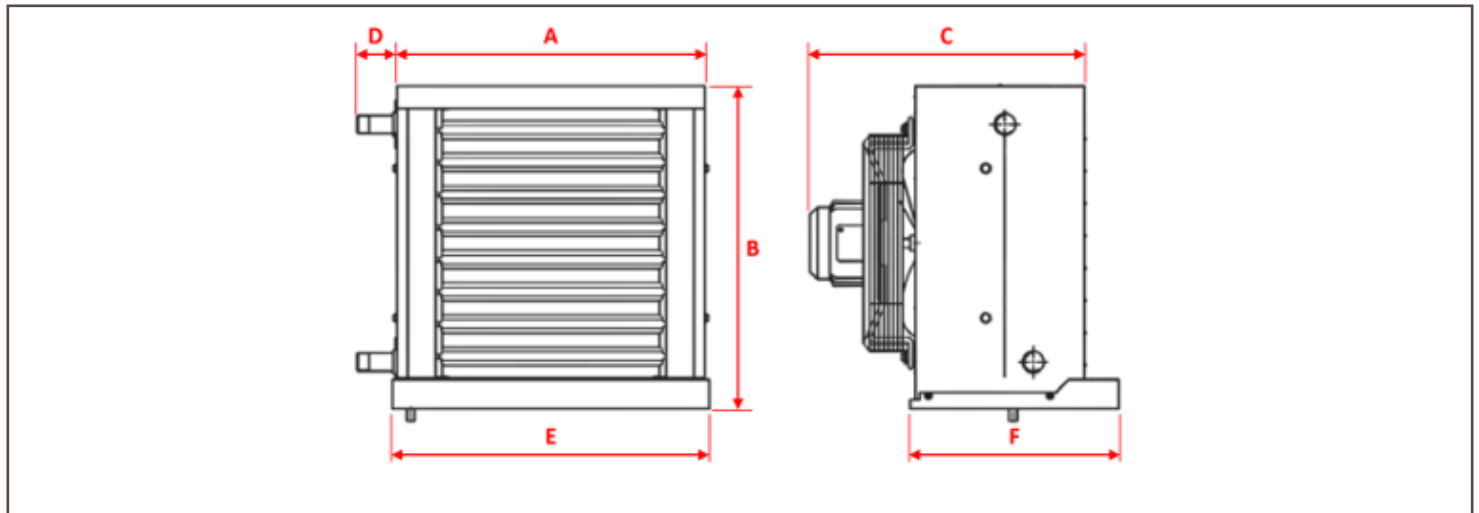

AXIL		AXIL Z (ELECTRICAL HEATER)			EQUITHERM (DESTRATIFIER)			
		4	5	6	4	5	6	9
A	mm	525	633	741	525	633	741	1009
B		526	636	743	526	636	743	1011
C		515	515	515	515	515	515	532
<b>Weight of standard units</b>								
Base unit	kg	22	30	38	14	20	25	42

\* Electrical box only available on AXIL Z.

