



e-Baltic

Air cooled rooftop packaged units

Installation, Operating and Maintenance



INSTALLATION, OPERATING & MAINTENANCE MANUAL

Ref : e-BALTIC-IOM-2022.02-EN

INTRODUCTION.....	1
GENERAL DESCRIPTION	1
COMPLIANCE WITH REGULATIONS AND DIRECTIVES.....	1
SAFETY CODES & REGULATIONS.....	1
MACHINE DESIGNATION	2
AIRFLOW LIMITS.....	2
EMC DIRECTIVE COMPLIANCE	3
F-Gas REGULATION	3
WARRANTY.....	3
SAFETY	4
NOTES FOR UNIT FITTED WITH GAS BURNER	5
LABELS.....	6
PED DIRECTIVE	7
MAIN SAFETY RECOMMENDATIONS	8
DELIVERY CHECKS.....	10
RATING PLATE	10
STORAGE	10
OPERATING LIMITS.....	11
MAINTENANCE KEY	12
CONDENSATE DRAINS.....	12
FLAMMABLE GASES	13
LABELS OF A FLAMMABLE GAS UNIT	13
TRANSPORT OF A FLAMMABLE GAS UNIT	13
RECEPTION CONTROLS FOR A FLAMMABLE GAS UNIT	13
SAFETY	14
SAFETY AREA	14
INSTALLATION ON A FLAMMABLE GAS UNIT.....	15
POWERING UP A UNIT CONTAINING FLAMMABLE GAS	15
ELECTRIC WIRING ON A UNIT CONTAINING FLAMMABLE GAS.....	15
INTERVENTION ON A UNIT CONTAINING FLAMMABLE GAS.....	15
CORRECTIVE MAINTENANCE ON R32 GAS UNIT:.....	16
ON-BOARD SAFETY ON R32 GAS UNIT:.....	17
HANDLING	21
MANDATORY HANDLING DEVICES	21
DIMENSIONS AND WEIGHTS	22
LIFTING THE UNIT	23
LIFTING THE ROOF CURBS	24
INSTALLATION	26
PRELIMINARY CHECKS	26
INSTALLATION REQUIREMENTS	26
CONNECTIONS	26
MINIMUM CLEARANCE AROUND THE UNIT	27
RECOMMENDATIONS FOR DUCTS CONNECTIONS.....	28
CUSTOMER WIRING	29
INSTALLATION ON A ROOFCURB.....	35

TYPE OF ROOFCURB	35
INSTALLATION ON AN ADAPTABLE ROOFCURB.....	36
CURBING AND FLASHING.....	37
NON-ADJUSTABLE NON-ASSEMBLED ROOFCURB INSTALLATION.....	38
TRANSITION CURB	40
FOAM INSULATION INSTALLING (C,D,E,E+) (SIZES 35, 45, 55, 65, 75, 85, 95, 115).....	40
FOAM GASKET INSTALLING (C,D,E,E+)(SIZES 35, 45, 55, 65, 75, 85, 95, 115)	40
ELECTRICAL CONNECTION.....	40
NON-EXTRACTION ADJUSTABLE ROOF CURB INSTALLATION	41
SPECIAL CASE OF ADJUSTABLE ROOFCURB WITHOUT EXTRACTION	41
HEAT RECOVERY	42
SENSOR MOUNTING	55
ECONOMISER AND EXTRACTION.....	56
COMMISIONING	57
CASING CONDENSATION RISK	57
BEFORE TURNING ON THE POWER.....	58
POWERING THE UNIT	58
CLIMATIC™ CONFIGURATION.....	59
FRESH AIR WOOD	61
INSTALLING	61
WIND DIRECTION	61
FILTERS	62
FILTER REPLACEMENT.....	62
REFRIGERANT CIRCUIT	63
GENERIC REFRIGERANT SKETCH.....	63
PREHEATING OF THE CRANKCASE HEATERS.....	67
ELECTRONIC EXPANSION VALVE	67
HEATING OPTION.....	68
HOT WATER COIL.....	68
ELECTRIC HEATERS	70
ELECTRICAL PREHEATER (C, D, E, E+ BOX) (SIZES 35,45,55,65,75,85,95,115)	71
CONDENSING GAS BURNER.....	72
RECOVERY WATER COIL C,D,E,E+ BOX (35,45,55,65,75,85,95,115).....	82
MAINTENANCE DIAGNOSTIC.....	83
MAINTENANCE PLAN	87
WARRANTY	91
TERMS AND CONDITIONS.....	91
LIFETIME OF THE EQUIPMENT.....	91
DISPOSAL OF THE EQUIPMENT.....	91

Original version is the English one.
Other versions are translations.

INTRODUCTION

We remind you that these instructions must be followed for operation, maintenance, repair and decommissioning of the product. Failure to follow these instructions will result in the offender assuming the manufacturer's responsibilities.

All the technical and technological information contained in this manual, including any drawing and technical descriptions provided by us, remain the property of LENNOX and must not be used (except in operation of this product), reproduced, issued to or made available to third parties without the prior written agreement of LENNOX.

GENERAL DESCRIPTION

The e-BALTIC range is an air cooled rooftop packaged unit designed for comfort air conditioning.

COMPLIANCE WITH REGULATIONS AND DIRECTIVES

The units comply with the directives and regulations which apply at the time of their placing on the market. For more information, please see the product's Declaration of Conformity.

SAFETY CODES & REGULATIONS

The unit is designed for outdoor installation only. The unit must be installed in accordance with local safety codes and regulations and can only be used in well ventilated area.

Inspections and requalification according pressure equipment directive must follow the local regulations where the unit is installed. Commissioning, monitoring, periodic verification and requalification obligations may be made mandatory in some countries. Please refer to it when installing the equipment.

You must read and be familiar with this operating manual prior to set up the equipment and commission the unit. Please closely follow the instructions.

We would like to stress the importance of training with respect to the correct handling of the unit.

Please consult LENNOX on the options available in this field.

It is important that this manual is stored in a permanent location in the vicinity of the unit

MACHINE DESIGNATION

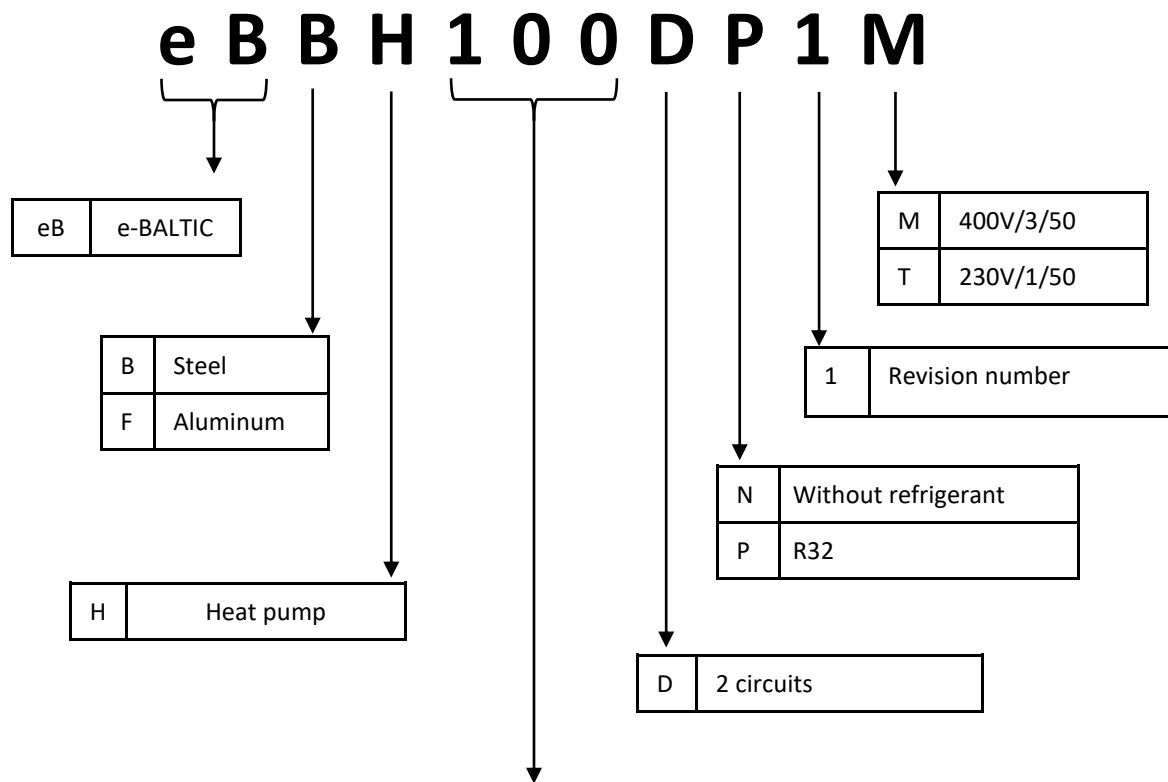

	C BOX		D BOX		E BOX		E+ BOX		F BOX		G BOX		H BOX	
Model designation	35	45	55	65	75	85	95	115	100	120	130	150	180	210

AIRFLOW LIMITS

Box	Model designation	Minimum airflow	Nominal airflow	Maximum airflow STD	Maximum airflow (option airflow boost)
C BOX	35	4200	7000	8000	8000
	45	4500	7500	8400	10000
D BOX	55	5000	8000	11200	11200
	65	6600	11000	13100	16000
E BOX	75	9500	13500	17000	22000
	85	9600	16000	19000	22000
E+ BOX	95	12300	20500	23000	23000
	115	13800	23000	23000	23000
F BOX	100	15000	20500	23000	23000
	120	15700	23000	23000	23000
G BOX	130	19000	26000	35000	35000
	150	21000	28000	35000	35000
H BOX	180	24000	33000	43000	43000
	210	28000	35000	43000	43000

EMC DIRECTIVE COMPLIANCE

WARNING:

This equipment is a "B class" according EMC Directive. In an industrial environment, this device can create radio electrical noise. In this case, the owner can be asked to take appropriated actions.

The units comply with the most stringent environmental standards according to the product's Declaration of Conformity.

This applies to all units installed with nominal amps below <75A:

- The short-circuit rate $R_{sce}=33$ is defined in the EN61000-3-12 standard relative to the harmonics readings on the supply network. The appliances compliant with the harmonic current limits equivalent to $R_{sce}=33$ can be connected in whatever connection point of the main supply system.
- The maximal allowable impedance of the main supply system $Z_{max}=0.30 \Omega$ for units C,D,E,E+ and $Z_{max}=0.143 \Omega$ for units F,G,H is defined by EN 61000-3-11 standard relative to the voltage variation, fluctuation and flicker readings. The connection to the supply is a conditional connection submitted to the preliminary agreement of the power supply local provider.

The differences between the various machines are only related to the power of the compressors and equipment that are associated. For conducted and radiated emission and immunity, these differences do not alter the results.

F-Gas REGULATION

PLEASE READ THE SAFETY DATA SHEET OF THE REFRIGERANT BEFORE ANY INTERVENTION OR INSTALLATION OF THE MACHINE.

Operators of refrigeration equipment's must comply with the obligations defined in

- Regulation on Fluorinated greenhouse gases (F Gas)
- Regulation on substances that deplete the ozone layer

Non-compliance with these requirements is an offence and liable of financial penalties.

Moreover, in case of problem it is mandatory to prove to the insurance company that the equipment complies with the F gas Regulation, as well as that all measures have been taken to safeguard people, environment and property.

WARRANTY

The warranty of the unit is subject to the warranty definitions as agreed upon in the order. It is expected that the design and installation of the unit utilizes good working practices. The warranty will be legally null and void if:

- Service and maintenance have not been executed in accordance with the regulations; repairs have not been carried out by LENNOX personnel or have been implemented without prior written permission by LENNOX.
- Modifications have been made to the equipment without prior written permission by LENNOX.
- Settings and protections have been modified without prior written permission by LENNOX.
- Non-original or other than the prescribed refrigerants or lubricants are used.
- The equipment has not been installed and/or connected in accordance with the installation instructions.
- The equipment is being used improperly, incorrectly, negligently or not in accordance with its nature and/or purpose.
- A flow protection device is not fitted.
- The unit maintenance booklet is not complete or not available.

In these circumstances LENNOX is indemnified from any product liability claims from third parties.

In the event of a warranty claim the machine serial number and LENNOX order number must be quoted.

The technical information and specifications contained in this manual are for reference only. The manufacturer reserves the right to modify these without warning and without obligation to modify equipment already sold.

SAFETY

The safety information contained in this manual is provided as a guide for the safe handling of this installation. LENNOX does not vouch for the completeness of this information and can therefore not accept liability for any possible omissions. Everyone involved in the product life cycle must perform a risk analysis. This applies to manufacturers, installers, maintainers and end-users. If risks are not eliminated or remain at unacceptable levels of occurrence or severity, they must be communicated to the next party (the customer in general) through the drafting of an installation, use, maintenance guide.

In the roof tops, heat is being transported by a pressurized refrigerant, with changes in pressure and temperature. For air cooled roof tops, fans have been provided to discharge heat into the environment. The protection of operating and maintenance personnel was central in the design of the roof top. Safety features have been included to prevent excessive pressure in the system. Sheet metal parts have been fitted to prevent inadvertent contact with (hot) pipes. For air cooled roof tops, the fans are equipped with protective grids and the electrical. The service panels can only be opened using tools by authorized personnel.

Notwithstanding that the units are equipped with extensive safety and protection features, the utmost care and attention is needed when carrying out operations on the machine. Furthermore, ear protection should be worn when working on or in the vicinity of the roof tops. All operations on the cooling circuit or electrical equipment should be carried out by authorized personnel.

It is essential to follow non exhaustive recommendations hereunder:

- Never work on a unit that is still energized. Wait 15 minutes before working on the machine after a power outage (discharge of the capacitors).
- Any manipulation (opening or closing) of a shut-off valve must be carried out by a qualified and authorized engineer. These procedures must be carried out with the unit shut-down.
- Never work an electrical component until the general power supply to the unit has been cut. During any maintenance operations on the unit, lock the power supply circuit in the open position ahead of the machine. If the work is interrupted, check the lock before resuming the work.
- **WARNING:** Even if the unit has been switched off, the power circuit remains energized, unless the unit or circuit disconnect switch is open. Refer to the wiring diagram for further details.
- In case of maintenance operations on fans (grills replacement ...) ensure that the power is shut off to avoid automatic restart.
- Before the opening of the refrigerant circuit, check the pressure with manometers or pressure sensors, and purge the circuit in accordance with current environmental directives.
- Never leave a unit stopped with valves closed on the liquid line, refrigerant could be trapped and the pressure would rise.
- All installation parts must be maintained by the personnel in charge, in order to avoid material deterioration and injuries to people. Faults and leaks must be repaired immediately. The authorized technician must have the responsibility to repair the fault immediately. Each time repairs have been carried out to the unit, the operation of the safety devices must be re-checked.
- Follow guidance and recommendations given in safety and machine standards such as EN378, ISO5149, etc. The use of the EN 378-2 standard provides you with the state of the art with regard to the essential safety requirements of the Machine Directives and PED.
- Do not use oxygen to purge lines or to pressurize a machine for any purpose. Oxygen gas reacts violently with oil, grease, and other common substances.
- Never exceed the specified maximum operating pressures.
- Verify the allowable maximum high- and low-side test pressures by checking the instructions in this manual and the pressures given on the unit name plate.
- Do not use air for leak testing. Use only nitrogen or dry nitrogen.
- Do not unweld or flame cut the refrigerant lines or any refrigerant circuit component until all refrigerant (liquid and vapor) has been removed from roof top. Successive purges with a neutral gas (such as dry nitrogen) are recommended to remove all traces of refrigerant. Refrigerant in contact with an open flame produces toxic gases.
- Do not siphon refrigerant
- Wearing PPE is mandatory (glasses, cuffs, gloves, masks). Avoid splashing refrigerant on the skin or in the eyes. Wash any spills from the skin with soap and water. If liquid refrigerant enters the eyes, immediately and abundantly flush the eyes with water and consult a doctor

NOTES FOR UNIT FITTED WITH GAS BURNER

THE UNIT MUST BE INSTALLED IN ACCORDANCE WITH LOCAL SAFETY CODES AND REGULATIONS AND CAN ONLY BE USED IN WELL VENTILATED AREA.

IF MACHINE IS INCLUDING GAS BURNER, MINIMUM CLEARANCE AROUND THE UNIT MUST BE AT LEAST 8 M TO ALLOW A PROPER COMBUSTION FUMES DILUTION. IF NOT POSSIBLE, THE FRESH AIR INTAKE MUST BE DUCTED AT LEAST 8 M AWAY FROM THE GAS BURNER EXHAUST.

PLEASE READ CAREFULLY THE MANUFACTURER'S INSTRUCTIONS BEFORE STARTING THIS UNIT

Switchgear must be installed on each unit in accordance with the Machine Directive and the standard EN 60204.

THIS MANUAL IS ONLY VALID FOR UNITS DISPLAYING THE FOLLOWING CODES:

GB IR GR DA NO FI IS

In case these symbols are not displayed on the unit, please refer to the technical documentation which will eventually detail any modifications required to the installation of the unit in a particular country

All the technical and technological information contained in this manual, including any drawing and technical descriptions provided by us, remain the property of Lennox and must not be used (except in operation of this product), reproduced, issued to or made available to third parts without the prior written agreement of Lennox.

The technical information and specifications contained in this manual are for reference only. The manufacturer reserves the right to modify these without warning and without obligation to modify equipment already sold

LABELS

The rooftop may be marked with the following warning labels to alert to potential hazards (on or near the potentially hazardous part). The rooftop may include the following labels

High temperatures	Low temperatures	Rotating parts	Sharp parts
Electrical Voltage	A2L: slightly flammable	Non-flammable liquefied gas (high pressure)	Flammable liquefied gas (high pressure)
Don't walk on it	Wear of PPE (Personal protective equipment)	Warning Inflammable dusty filters	Don't strap
Gravity center	Warning main switch supplied from bottom	EUROVENT certification	
Protection by water filter mandatory	Protection by strainer filter mandatory		
OK to send document	Information to read	Electrical connections can loosen during transport. Please check them before start-up.	
CMIM marking (Morocco)	CE marking	CA marking (UK)	EAC Marking (Russia)

Regularly check that the warning labels are still in the correct positions on the machine and replace them if necessary.

PED DIRECTIVE

For units covered by the Pressure Equipment Directive (see EU Declaration of Conformity).



Warning:

1. Attention: The high-pressure safety switches are essential elements which guarantee the system remains within the admissible operating limits. Before switching on the installation, always ensure all electrical connections are correct on these elements. Carry out a test to ensure the electrical power supply is effectively turned off when the pressure switch attains its set value.
2. In case of installation in a seismic zone or in a zone which may be effected by violent natural occurrences such as storms, tornados, floods, tidal waves, etc..., the installer and/or operator will refer to valid standards and regulations in order to ensure the devices required are available as our units are not designed to operate under such conditions without prior precautions.
3. The equipment is not designed to resist fire. The installation site will therefore have to respect valid standards about protection against fire (emergency instructions, map...).
4. In case of exposure to corrosive external atmospheres or products, the installer and/or operator shall take the necessary precautions to avoid damage to the equipment and will make sure the equipment provided has the necessary and sufficient anti-corrosion protection.
5. To respect a sufficient number of supports for the piping according to their size and weight under operating conditions and to design the piping to avoid a water hammer phenomenon
6. For technical reasons, it is not possible to carry out hydrostatic tests on all our units. Our rooftops are hermetically sealed products according to the definition of the F-Gas directive and certain local regulations such as CH35 in France. Leak tests are carried out as a compensatory measure. (The entire circuit is checked using leak detectors). For machines charged with refrigerant, at the end of the test, an HP test is carried out in the factory to make sure the pressure switch is working properly
7. Before any work is carried out on the refrigeration circuit, the dry air or nitrogen pressure our units are supplied with must be released (For units not charged with refrigerant in the factory.)
8. If a valve is fitted, the emissions of refrigerant via the safety relief valves must be directed to the outside, to a place free of ignition sources, fresh air intake and human presence.. The valve should be sized and connected in compliance with current standards.
9. Installation and maintenance of these machines must be carried out by personnel qualified to work on refrigeration equipment.
10. All interventions must be carried out in conformity with valid safety regulations (e. g.: EN 378), as well as the recommendations indicated on the labels and handbooks provided with the machine. All actions shall be taken to avoid access of unauthorized persons.
11. It is essential that any pipework or other components of the refrigeration circuit hazardous to people because of their surface temperature are insulated or identified.
12. Ensure that the installation zone (room or area) of the machine has restricted access and ensure the good condition of the covering.

MAIN SAFETY RECOMMENDATIONS

All work on the unit must be carried out by a qualified and authorized employee.

Non-compliance with the following instructions may result in injury or serious accidents.

WORK ON THE UNIT:

The risk analyses of our machines are carried out considering operation in a standard environment with unpolluted air. For other applications, which do not meet this criterion (Kitchen, industry, ...) please contact your local sales representative.

- The unit shall be isolated from the electrical supply by disconnection and locking using the main isolating switch.
- Workers shall wear the appropriate personal protective equipment (helmet, gloves, glasses, etc.).

WORK ON THE ELECTRICAL SYSTEM:

- Work on electric components shall be performed with the power off by employees having valid electrical qualification and authorization.

WORK ON THE REFRIGERATING CIRCUIT(S):

- Monitoring of the pressures, draining and filling of the system under pressure shall be carried out using equipment designed for this purpose and suitable for the refrigerant contained in the rooftop.
- To prevent the risk of explosion due to spraying of coolant and oil, the relevant circuit shall be drained and at zero pressure before any disassembly or unbracing of the refrigerating parts takes place.
- There is a residual risk of pressure build-up by degassing the oil or by heating the exchangers after the circuit has been drained. Zero pressure shall be maintained by venting the drain connection to the atmosphere on the low-pressure side.
- The brazing shall be carried out by a qualified brazier. The brazing shall comply with standard EN1044 AG107 (minimum 30% silver).

REPLACING COMPONENTS, EQUIPMENT AND PIPING:

- Replacement shall be carried out using spare parts, or using parts approved by Lennox.
- Only the refrigerant shown on the manufacturer's nameplate shall be used.

PARAMETERING AND CONTROL:

- For any intervention related to component parameterization, controls and unit operation management, refer to "Climatic Roof-Top and Unitary" user manual.

FILTERS:

- Choose the filters fire classification's according to local regulations

TRANSPORT – HANDLING

- Never lift the unit without forklift protections
- Remove the forklift protection before installation
- If access to the installation is difficult, provide guard rail. This recommendation is valid for installations in general and for return and curbs. It's also valid to reach other parts of the unit: filters, refrigerant circuit, etc...
- It's advised to fix curbs and roofcurbs to the unit
- Installation of the unit and accessibility must be compliant with the local regulations. Ensure that all access equipment allow maintenance operation in safety (electrical cabinet, main switch, panels, filter, refrigerant circuit...)
- It is strictly forbidden to walk or store equipment or material on top of the rooftop unit
- Equipment designed to withstand transport and handling according to the established protocol (for the handling protocol, please refer to the installation instructions for the relevant product range).
- All unloading operations must be carried out with suitable equipment (crane, forklift truck, etc.).
- When using a forklift truck, you must respect the positions and the direction of handling indicated on the products.
- The equipment must be handled with care to avoid damage to the bodywork, pipework, condenser, etc.

ROOFTOP INSTALLATION IN HEAVY WIND LOCATIONS

- The roofcurbs (vertical & horizontal) and rooftops are designed to withstand winds up to 80 km/h. Above this limit, it's recommended to take appropriate actions to secure the installation.
- Ensure the fresh air inlet does not face prevailing wind direction.

COMMISSIONING:

- It must only be carried out by trained refrigeration engineers.
- Don't forget to open the insulation valve on the liquid line before starting the unit

FAN COMPARTMENT:

- Stop the power before accessing the fan compartment.

Warning: the unit is working under pressure. Never open the panels when the unit is working. Even after shutting down the unit, wait for 2 minutes until the fans are completely stopped before opening any panel.

GAS:

- Any work on gas module must be carried out by qualified personnel
- A unit with gas module must be installed in accordance with local safety codes and regulations and can only be used in planned installation conditions for outdoor.
- Before commissioning this type of unit, it's mandatory to ensure that the gas distribution system is compatible with the adjustment and settings of the unit.

WARNING:

- The units are not designed to resist to a fire. The installation site must comply with the standards relating to fire protection.
- In case of installation of the units in an area recognized as being potentially at risk for natural phenomena (tornado, earthquake, tidal wave, lightning...), please follow the standards and regulations, and provide the necessary devices to prevent from these risks.
- In the event of fire, refrigerating circuits are liable to rise in pressure above the maximum working pressure and release refrigerant and oil. Please take this into account in your risk analyses.

DELIVERY CHECKS

On receipt of a new equipment please check the following points. It is the customer's responsibility to ensure that the products are in good working order:

- The exterior has not been damaged in any way.
- The lifting and handling equipment are suitable for the equipment and comply with the specifications of the handling instructions enclosed here-in.
- Accessories ordered for on-site installation have been delivered and are in good working order.
- The equipment supplied corresponds to the order and matches the delivery note.

If the product is damaged, exact details must be confirmed in writing by registered post to the shipping company within 48 hours of delivery (working days). A copy of the letter must be addressed to Lennox and the supplier or distributor for information purposes. Failure to comply will invalidate any claim against the shipping company.

RATING PLATE

The rating plate provides a complete reference for the model and ensures that the unit corresponds to the model ordered. It states the electrical power consumption of the unit on start-up, its rated power and its supply voltage. The supply voltage must not deviate beyond: +5/-5%. The start-up power is the maximum value likely to be achieved for the specified operational voltage. The customer must have a suitable electrical supply. It is therefore important to check whether the supply voltage stated on the unit's rating plate is compatible with that of the mains electrical supply.

STORAGE

When units are delivered on site they are not always required immediately and are sometimes put into storage. In the event of medium to long-term storage, we recommend the following procedures:

- Ensure that there is no water in the hydraulic systems (for water condensing rooftops)
- Keep the heat exchanger protection if any.
- Keep protective plastic film in position.
- Ensure the electrical panels are closed.
- Keep all items and options supplied in a dry and clean place for future assembly before using the equipment.
- Store the unit on an appropriate place (flat surface).
- Storage temperature must be respected according to the information given on the rating plate

It is strongly recommended to store units in a dry, sheltered place (in particular for units that will be installed indoor).

OPERATING LIMITS

MACHINE OPERATING LIMITS

The machine must work without thermodynamics with an outside air between -20°C and 50°C

THERMODYNAMIC OPERATING LIMITS

SIZE 35, 55, 65,75,85

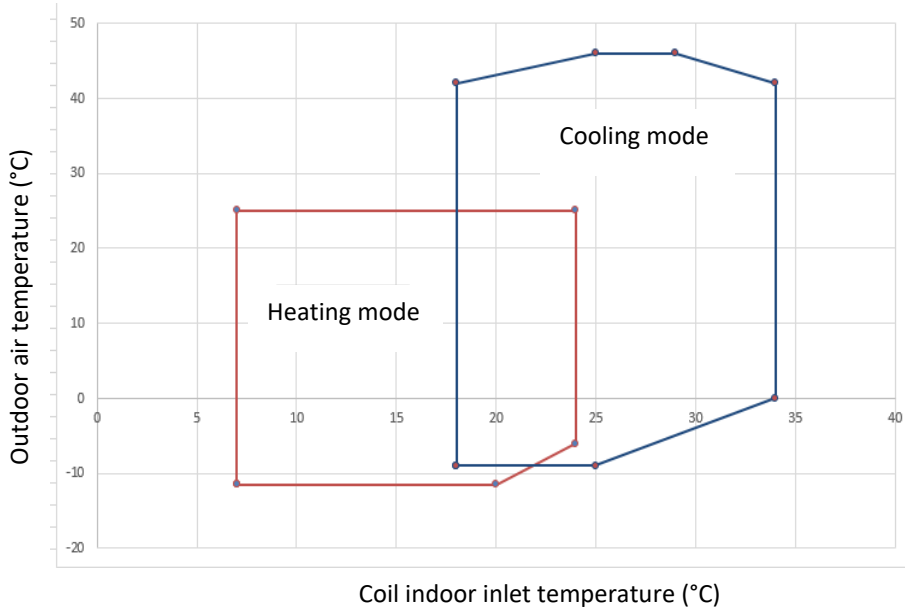

SIZE 45, 95, 115, 100, 120, 130, 150, 180, 210

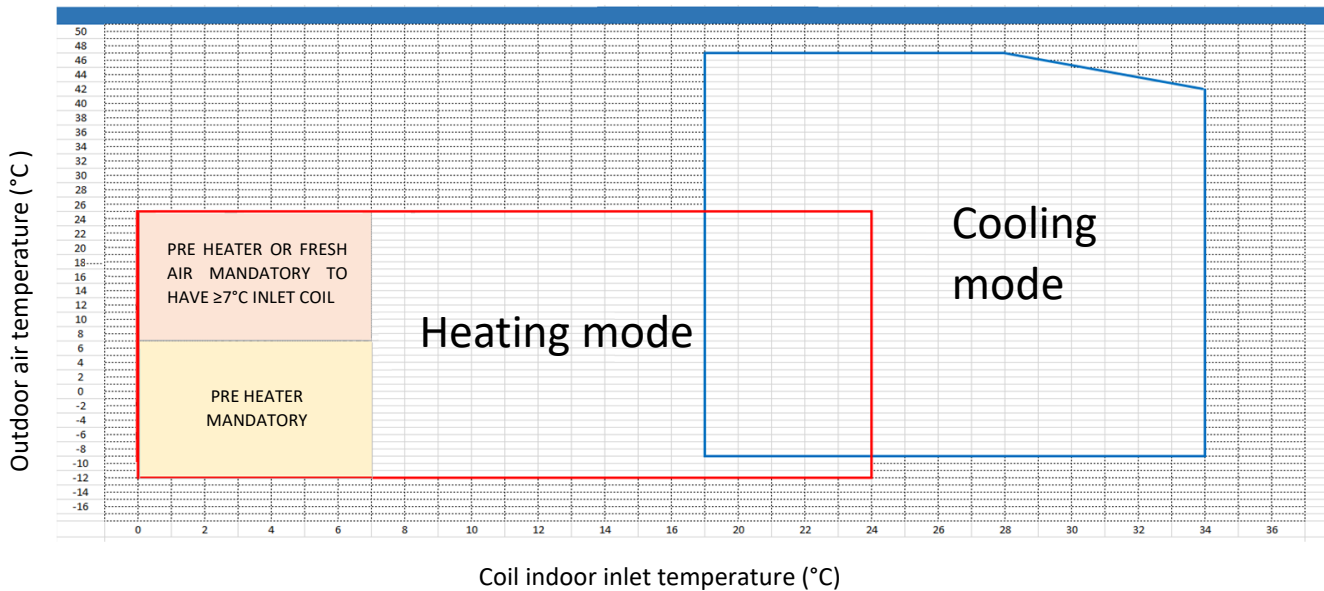

MAINTENANCE KEY

On delivery we recommend that you keep the key which is attached to an eyebolt in a safe and accessible place. This allows you to open the panels for maintenance and installation work.

The locks are $\frac{1}{4}$ turn + then tighter.

**CONDENSATE DRAINS**

The condensate drains are not assembled when delivered and are stored in the electrical panel with their clamping collars.

To assemble them, insert them on the condensate tray outlets.

The drains must be installed in vertical position.



FLAMMABLE GASES

As standard, the eBaltic range is supplied with R32 refrigerant which is a flammable gas classified A2L (slightly flammable).

A2L / A2 / A3 flammable gases are subject to more important safety regulations than gases classified A1. This section summarizes the standard and provides specific Lennox recommendations. This section is based on the EN 378, EN 60079-10-1 standards as well as numerical simulations and tests related to the flammability risk carried out on these products. It provides the recommendations to be considered so that the product is installed, used, maintained and destroyed at the end of its life cycle without putting the actors in the product life cycle at risk.

Flammability class	
A1	Non-flammable
A2L	Slightly flammable
A2	Low flammable
A3	Highly flammable

LABELS OF A FLAMMABLE GAS UNIT



The A2L logo on the nameplate indicates that the product contains refrigerant of the slightly flammable category. It is also positioned on schraders where refrigeration components can be connected for maintenance. This label tells you that there is a potential risk of a flammable gas leak and that this should be taken into account in the operational risk analysis.

TRANSPORT OF A FLAMMABLE GAS UNIT

Machines loaded with A2L refrigerant must comply with the ADR rules (Accord for dangerous goods by road), in particular UN 3358. Please plan the route in accordance with this class. In the case of specific air transport requiring machines not charged with refrigerant, please contact your Lennox contact.

UN3358 transports are not allowed in Eurotunnel and tunnels of category D and E.

Containers must be fitted with stickers according to the plan below.

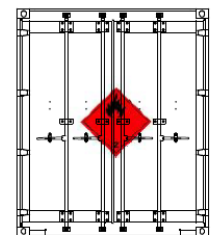
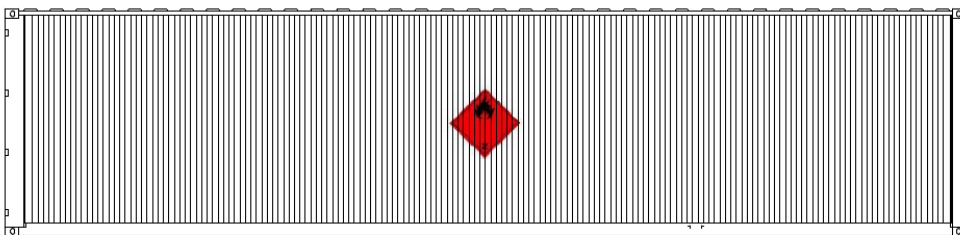

In the transport voucher, note: UN3358 Refrigerant units 2.1

In case the machine contains more than 12Kg of refrigerant, please also note the total amount of refrigerant on the transport voucher.

In the case of maritime transport, the IMDG (International Maritime Dangerous Goods Code) is based on the same rules as the ADR. Some specific local rules may apply (especially in Asia).

RECEPTION CONTROLS FOR A FLAMMABLE GAS UNIT

Please do not approach the container or truck in the presence of an open flame, an electric power source, a cell phone, or any other heat source whose temperature would exceed 500°C.

Likewise, if the product had to be stored prior to installation, please store it in a place free from potential sources of ignition as described above.

SAFETY

Persons working on refrigeration systems using flammable fluids must have the necessary skills in accordance with EN 13313 for the safe handling of these flammable fluids.

- Knowledge of the legislation, regulations and standards concerning flammable refrigerants.
- Knowledge of fluids and their handling.

These skills must be supported by appropriate training.

Only equipment designed for use with flammable refrigerants should be used and all work performed on the equipment should be in accordance with local regulations and standards. Of course, all work must be carried out in a professional manner.

To ensure the absence of a secondary ATEX zone, maintainers should :

- Set up a periodic leakage inspection plan to ensure that the product's leakage level is maintained.
- Set up an inspection and maintenance plan to avoid deterioration of the product that could lead to an accidental leak during the life of the equipment.
 - Corrosion: do not use detergents. Do not use in an atmosphere corrosive to copper and aluminum without protecting the sensitive elements of the exchanger.
 - Freezing of the heat exchanger coil: Check regularly that the coil is not frozen. Check that the defrosting system is working properly and that it is effective.
 - Abnormal vibrations: check that the pipes are properly maintained.
- If a safety chain is installed, please maintain the detection system and the associated control chain according to EN 60079-29-1 and EN 50495.

SAFETY AREA

Our products (Rooftops, chillers) and quasi-machines (evaporators, air-cooled condensers, ...) are hermetically sealed and carry the CE mark. They are designed to contain slightly flammable A2L refrigerants. As such they are not considered as a source of release as defined by the ATEX 60079-10-1 directive in normal operation. In France, they are exempt from the measures described in § 3 of the CH35 of the regulation governing the safety of buildings open to the public (ERP).

A formalized periodic inspection of the product's hermeticity will guarantee the preservation of this high level of hermeticity. Nevertheless, in abnormal operating conditions, leaks may occur (poor maintenance, maintenance with opening of the refrigeration circuit). For these cases, prior to placing these products on the market, we carried out studies in accordance with standards EN 60079-10-1 and EN 378. Thus the unit installed according to our recommendations and well maintained does not generate an ATEX zone.

Moreover, the product is equipped with safety devices against the risk of flammability. (see § On-board safety with R32 gas).

Please maintain the detection system and the associated control chain according to EN 60079-29-1 and EN 50495. In case of maintenance we recommend that the operators be equipped with an explosimeter, switch off the power supply to the unit and do not approach any potential source of ignition without first checking the absence of a potentially flammable area due to an undetected leak.

The end user should update the DUER (Document Unique d'Evaluation des Risques) indicating the presence on his site of products charged with R32 fluid, and train his personnel on the good practices to be adopted for a safe use.

INSTALLATION ON A FLAMMABLE GAS UNIT

ATEX : It is forbidden to store and install the machine in an ATEX area.

In the immediate area of the unit (proximity distance \leq to 2m):

- The presence, even temporary, of ignition sources is prohibited (electrical or heat sources see EN 378),
- It is forbidden to install fresh air vents in the building or in extracts

For ducting/ducted units, ensure that no sources of ignition as defined by EN378 (e.g. electrical and heat) are installed in or near the ducts.

Minimum building volume:

For a given volume of building to be ventilated, the standard gives a maximum load per circuit in flammable fluid A2L/A2/A3.

According to the standard, for R32 fluid, Lennox recommends a maximum load per circuit of :

If the mass of refrigerant is between 1.8 and 12kg :

$$m \leq \sqrt{A} \times h \times 0.571$$

If the mass of refrigerant is between 12 and 60kg :

$$m \leq A \times h \times 0.061$$

m: mass of refrigerant A2L (kg)

A : area of the room (in m²)

h : air supply height in the room (in m) (max: 2.2)

Example for a 2.2m high room:

	C Box		D Box		E Box		E+ Box		F Box		G Box		H Box	
	35	45	55	65	75	85	95	115	100	120	130	150	180	210
R32 max load per circuit	6,5	6,5	6,2	6,2	5,7	5,7	7,7	7,8	7,3	7,4	11,3	11,3	12,8	13,5
A_{min}	26,7	26,7	24,3	24,3	20,5	20,5	37,5	38,5	33,7	34,7	80,2	80,2	95,3	100,6

POWERING UP A UNIT CONTAINING FLAMMABLE GAS

Before switching on the power supply, please carry out a refrigerant leak detection using an appropriate device to ensure that there is no refrigerant around the machine. . Please perform a refrigerant detection with a suitable and calibrated detector to ensure that there is no gas around the unit.

ELECTRIC WIRING ON A UNIT CONTAINING FLAMMABLE GAS

When a cable passes through a wall, be sure to use a cable gland to ensure that the cable is sealed and insulated. This insulation prevents any electric arcs that could ignite the refrigerant if leaked.

INTERVENTION ON A UNIT CONTAINING FLAMMABLE GAS

Before any intervention on a machine with A2L / A2 / A3 flammable fluid, please carry out a refrigerant leak detection using an appropriate device to ensure that there is no refrigerant around the machine.

When working on a machine with flammable fluid A2L/A2/A3, do not cause sources of flammability in the area near the rooftop (see above). For example: do not smoke, make phone calls, do not use walkie-talkies.

CORRECTIVE MAINTENANCE ON R32 GAS UNIT:

The following precautions, specific to this gas, must be taken when using the R32 refrigerant:

- The vacuum pump must be fitted with a non-return valve or a solenoid valve and comply with R32 (A2L).
- The pressure control, draining and filling operations of the pressurized system must be carried out using the fittings specified for this purpose and the appropriate equipment.
- Use only pipe cutters and no torches to open the pipes.
- The load must be applied in the liquid phase.
- Always use a scale to charge the refrigerant.
- Use the leak detector suitable for R32 refrigerant.
- Do not use mineral oil, only synthetic oil for boring, expanding or making connections.
- Keep the pipes closed before using them and pay close attention to any traces of humidity and dirt (dust, filings, burrs, etc.).
- Brazing must always be carried out in a nitrogen atmosphere.
- The drill bits must always be sharp.
- The refrigerant bottle must contain at least 2% of the total amount.
- The brazing operation must be performed by a professional.

WARNING

Care must be taken to remove refrigerant from the system before cutting or unbrazing any piping with a tool suitable for use with A2L fluids.

We recommend the following protocol before any piping work:

- To avoid any risk of explosion due to the spraying of refrigerant liquid and oil, the circuit must be drained and display a relative pressure of zero during the disassembling or unbrazing of parts of the refrigerant circuit.
- Vacuum with A2L compatible equipment and recharge with dry nitrogen to allow the fluid dissolved in the oil to degas.
- Repeat these operations twice.
- Once the circuit has been drained, there is a residual risk of pressure build-up by degassing the oil or due to the heat from the exchangers. To keep the pressure at zero, the pipe connection must be bled from the low pressure side.

Vacuum procedure

- Connect the vacuum pump to the HP line and to the BP line.
- Draw vacuum (P=1 Pa). Break the vacuum with dry nitrogen. Draw vacuum again (P=1 Pa), the residual moisture content must be less than 50 ppm.
- Perform a vacuum test (15 minutes at maximum 70 Pa).

The compressors must be switched off during the vacuum test!

ON-BOARD SAFETY ON R32 GAS UNIT:

A2L Rooftop units are supplied with leak detectors. They are connected to a NO/NC contact, provided to the customer, which closes in case of a major leak.

FIRE AND SMOKE SAFETY HAVE PRIORITY OVER LEAK DETECTION.

The R32 detector is composed of a gas sensor on ventilation side and a control board. The control board is only intended for indoor application. Do not change the position of the sensor elements.

The sensitive layer of the sensors reacts chemically in the presence of R32, changing its conductivity. The different oxidation processes modify the conductivity and therefore the measurement, which is why regular calibrations are necessary. Regular maintenance must be carried out in accordance with the instructions. Do not generate electrostatic discharges.

The following are currently known to poison the sensor and change its sensitivity:

- Polymerizing substances such as ethylene oxide, acrylonitrile, butadiene, styrene, silicone.
- Catalytic poisons, such as Sulphur and phosphorus compounds, silicon compounds, metallic vapors.
- Organic solvents

Permissible temperature	-35°C to +60°C
Allowable humidity	15 to 90% relative humidity without condensation
Permissible pressure	0.9 to 1.1 bar
Storage temperature	0°C to +60°C
Storage	Up to 12 months
Calibration interval	12 months

Gas type	MSR group	MSR	Calibration gas	Group	Measuring range	Relative density
R32	FR08	2080-02	R407c	CFC	0-50%	1.8 bar

WARNING :

Connecting the 24 V fieldbus voltage to terminal X7 of the local bus can destroy the board.

COMMISSIONING

Commissioning must only be carried out by people authorized by Lennox.

Remove the cap from the refrigerant detection optical head during commissioning

A documented functional test must be carried out during commissioning (without the presence of gas).

SENSOR CARTRIDGE REPLACEMENT

- **Unplug the sensitive element.**
- **Loosen the lock nut.**
- **Remove the obsolete sensitive element.**
- **Take the calibrated sensitive element out of its original packaging, check the type of gas, the measuring range and the valid calibration date.**
- **Insert the sensitive element and tighten with the lock nut.**
- **Connect the plug of the sensitive element.**
- **Follow the local standard concerning electronic equipment waste.**

INSPECTION

Gas sensors must be checked regularly by a competent person. The following must be checked :

- Maintenance/calibration interval not exceeded.
- Visual inspection of the sensor, wiring, etc.
- Remove dust deposits, especially at the gas inlet.
- The filter at the gas inlet must be replaced if it is dirty.

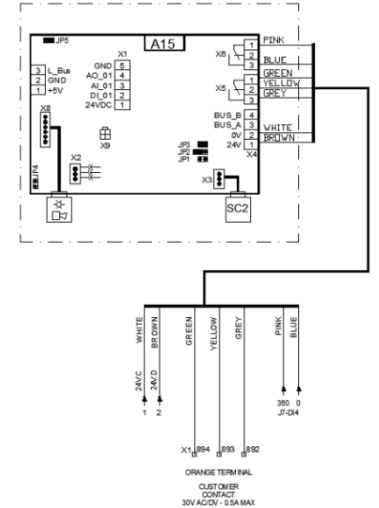

MAINTENANCE AND CALIBRATION

During maintenance, you must perform the calibration and functional test, see below, in addition to the inspection. A fixed calibration interval is recorded for each sensor type.

For an SC2 sensor, if this interval is exceeded, a digital maintenance message is generated and transmitted. Performing calibration automatically clears this message.

Calibration procedure with tool or display

- Open the calibration mode in the dialog box.
- Wait until the warm-up time (300 s) has elapsed.

Zero-Point Calibration :

- Connect the display, press ENTER.
- Press the down arrow to go to "Installation & Calibration", press ENTER.
- The "service mode" screen appears, press ENTER.
- Enter the password 1234 with the arrows only and confirm with ENTER.
- Switch the mode service to ON (ENTER + arrow + ENTER to confirm) → The buzzer beeps
- Use the arrows to go to "calibration", press ENTER.
- Select in the menu the DP1 or DP2 sensor according to the one you want to calibrate and validate with INPUT.
- Use the arrows to select "Zero DP 1" and confirm with ENTER.
- Enter the password 5412 with the arrows and confirm with ENTER.
- Press ENTER once
- Wait 5 seconds and press ENTER (SAVE should appear on the display).
- Press ESC twice to return to the previous menus and deactivate the "service mode".

Calibration:

- Open the test gas dialog box and enter the concentration of the test gas used (1000 ppm).
- Open the Calibration dialog box.
- Enter the gas type. Pressure 1bar \pm 10%, flow rate 150 ml / min.
- Perform calibration.
- Record the new values after a successful calibration.

MEANING OF LEDS

The alarm relay is used to raise the presence of gas. The fault relay is used to detect the presence of a fault on the sensor.

Start up and normal operation

	LED			Analog output	Relay	
	Power	Alarm	Default		Alarm	Default
Start-up						
↓						
Diagnostic (0.5sec)				< 2 mA	OFF	Fault ⁴
↓						
Preheat				< 2 mA	OFF	Fault ⁴
↓						
Normal operation		²		4 -20 mA ¹	³	OK ⁵

Specific operations or alerts

	LED			Analog output Power	Relay	
	Power	Alarm	Default		Alarm	Default
Maintenance message		²		4 -20 mA ¹	³	OK ⁵
Special mode		⁷		2 mA	⁷	Fault ⁴
Fault detected		⁷		2 mA	⁷	Fault ⁴
Processor failure				< 1 mA	OFF	Fault ⁴

Bump test

	LED			Analog output Power	Relay	
	Power	Alarm	Default		Alarm	Default
Normal operation		²		4 -20 mA ¹	³	OK ⁵
↓ Press the test button for 20 seconds						
Bump test				20 mA	OFF	OK ⁵
↓						
Release the test button Normal operation		²		4 -20 mA ¹	³	OK ⁵

¹ The status depends on the concentration of the gas measured.

² The status depends on the concentration of the gas measured and the alarm threshold.

³ The status depends on the concentration of the gas measured, the alarm threshold and the operating mode.

⁴ Relay deactivated, contact open.

⁵ Relay activated, contact closed.

⁶ LED cyclically flashing during message sending.

⁷ Previous status does not change.

HANDLING

MANDATORY HANDLING DEVICES

Handling slings to guide the unit towards the roofcurb

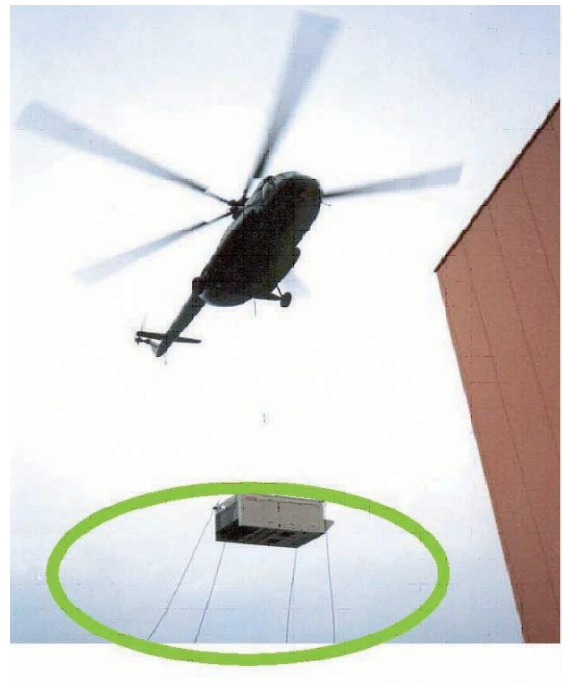

Vacuum lifting beam to position the unit

COMPLIANT



NON COMPLIANT



DIMENSIONS AND WEIGHTS

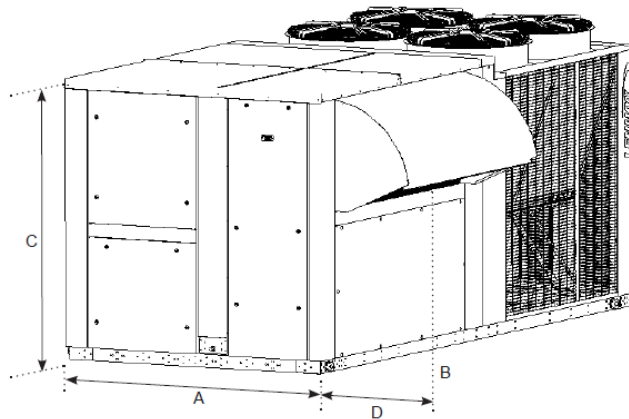

e-BALTIC Size	35	45	55	65	75	85	95	115	100	120	130	150	180	210
Model (C, D, E, E+, F, G, H box)	C BOX		D BOX		E BOX		E+ BOX		F BOX		G BOX		H BOX	
A (mm)	2260		2260		2260		2260		2245		2245		2260	
B (mm)	2250		2810		3690		3690		3700		4360		5170	
C (mm)	1265		1265		1265		1620		1780		1885		2235	
D (mm)	449		449		449		449		485		522		687	
Weight of basic units without any options. All weights are given in kg (+/- 5%).														
Individual weight of a given rooftop is indicated on the rating plate and on the sale's offer.														
For each product to be lifted, check in advance the compatibility between the load and the capacity of the handling equipment.														
Basic unit	640	640	980	980	1150	1150	1300	1300	1300	1350	1700	1700	2150	2150

LIFTING THE UNIT

LIFTING SHACKLES DIMENSIONS

Use lifting shackles on each lifting lug located on each angle of the unit. Maximum diameter of the ring shaft = 20 mm

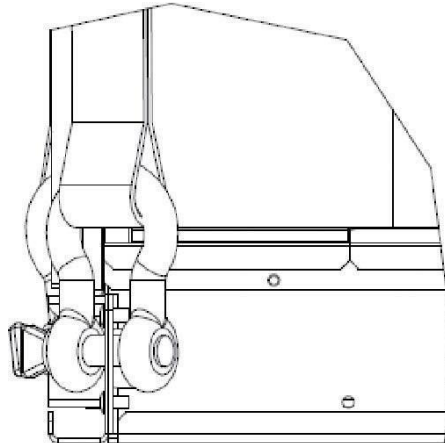

UNITS C, D, E, E+ (SIZES 35, 45, 55, 65, 75, 85, 95, 115)

The unit must be lifted using spacing beams to avoid the belts damages to the casing. Spacing beams must have a length equal to the machine width – i.e. 2250 mm.

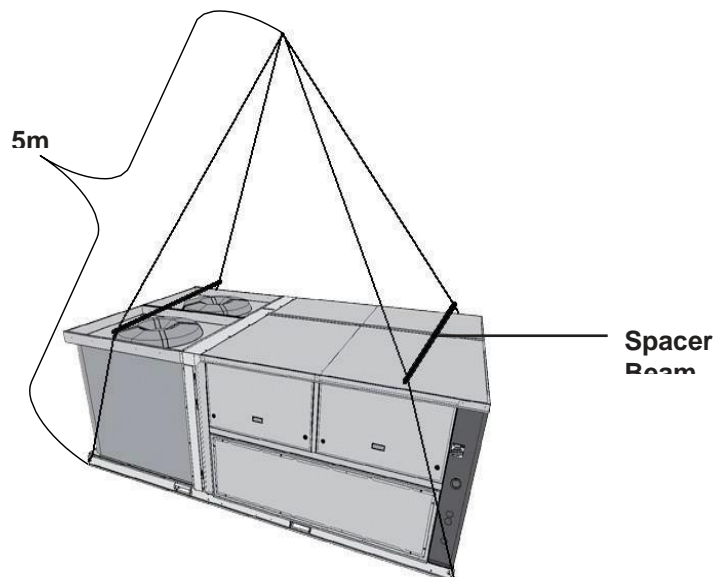

UNITS F, G, H (TAILLES 100, 120, 130, 150, 180, 210)

As shown on the picture below, a lifting frame is necessary; After lifting, withdraw angle's feet and lifting lugs.



LIFTING THE ROOF CURBS

Do not install the unit on the refrigeration side on Roofcurb.

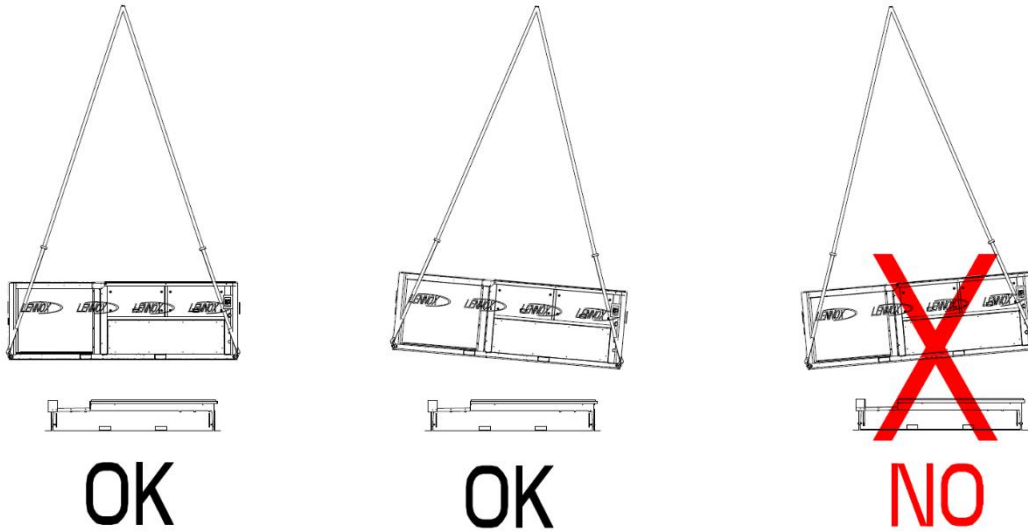

DUCTING CONNECTION DETAILS (C,D,E,E+) (SIZES 35, 45, 55, 65, 75, 85, 95, 115)

The supply and return air ducts can be secured to the 30 mm flanges at the bottom of the roofcurb. Any ducting weight above 100 kg must be fixed independently to other building frames.

Minimum
distance : 30
mm



FORKLIFT PROTECTIONS

WARNING: NEVER LIFT THE UNIT WITHOUT FORKLIFT PROTECTIONS

Do not remove the unit plastic cover while lifting.

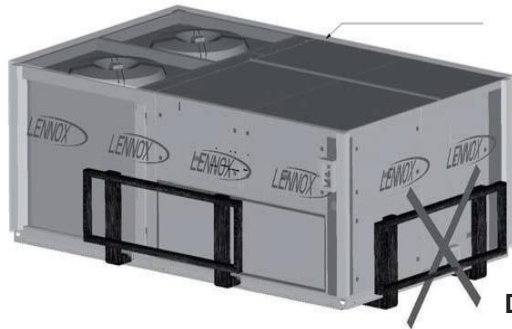

NO

DO NOT LIFT THIS SIDE

Do not lift the unit by the side (coil end side or drain pan outlet side). This will damage the unit. Lift the unit on the long side using a forklift with dimensions according to the figure below. Do not remove the unit plastic cover while lifting.

REMOVING THE FORKLIFT PROTECTION LOCATED UNDER THE MACHINE (Units C, D, E, E+) (SIZES 35, 45, 55, 65, 75, 85, 95, 115)

Before installation, remove the forklift protection which is located under machine desk.

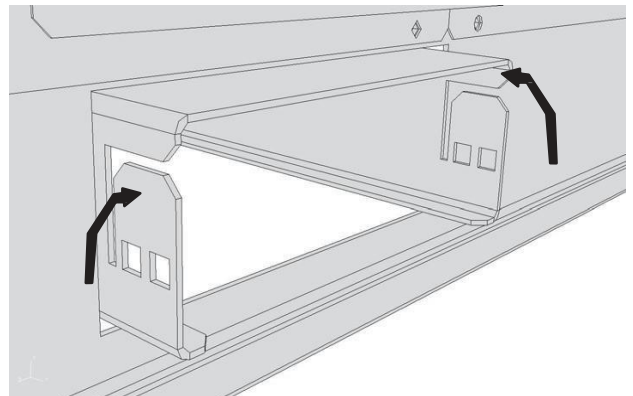
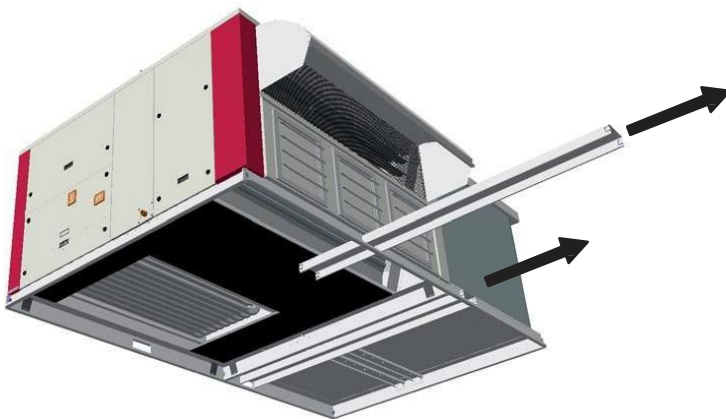

IMPORTANT note about forklift protection removal

Take care not to hurt anybody when removing the forklift rails. Locate the machine on a safe area while removing the forklift rails from the machine

WARNING: NEVER LIFT THE UNIT WITHOUT FORKLIFT PROTECTIONS

REMOVE THE FORKLIFT PROTECTIONS BEFORE INSTALLATION

INSTALLATION

PRELIMINARY CHECKS

Before installing the equipment, the following points MUST be checked:

- Have the forklift protections been removed?
- Is there sufficient space for the equipment?
- Is the surface on which the equipment is to be installed sufficiently solid to withstand its weight? A detailed study of the frame must be made beforehand.
- Do the supply and return ductwork openings excessively weaken the structure?
- Are there any obstructing items which could hinder the operation of the equipment?
- Does the electrical power available correspond to the equipment's electrical specifications?
- Is drainage provided for the condensate?
- Is there sufficient access for maintenance?
- Installation of the equipment could require different lifting methods which may vary with each installation (helicopter or crane). Have these been evaluated?
- Ensure that the unit is installed in accordance with the installation instructions and local applicable codes.
- Check to ensure that the refrigerant lines do not rub against the cabinet or against other refrigerant lines.

In general, make sure no obstacles (walls, trees or roof ledges) are obstructing the duct connections or hindering assembly and maintenance access

INSTALLATION REQUIREMENTS

The surface on which the equipment is to be installed must be clean and free of any obstacles which could hinder the flow of air to the condensers:

- Avoid installing two units side by side or close to each other as this may restrict the airflow to the condensers.
- Uneven surfaces are prohibited. The surface must be flat and respect a maximal flatness of 0.5mm per linear meter (in both directions length and width).
- The entire surface of the chassis must rest on a support (except for the Lennox PIED option provided for this purpose).
- For the installation of a machine without the roofcurb or box supplied by Lennox, it is imperative that the load of the machine is evenly distributed under the entire frame.

Before installing a packaged Rooftop unit, it is important to understand:

- The direction of prevailing winds
- The direction and position of air flows.
- The external dimensions of the unit and the dimensions of the supply and return air connections.
- The arrangement of the doors and the space required to open them to access the various components

CONNECTIONS

- Ensure that all the pipework crossing walls or roofs are secured, sealed and insulated.
- To avoid condensation problems, make sure that all pipes are insulated according to the temperatures of fluids and type of crossed premises.

NOTE: The protection sheets fitted to the finned surfaces must be removed prior to start up

The customer must provide the appropriate equipment to protect the supply line to the unit. A differential of 300 mA is recommended.

If the unit is fitted with variable speed fan condensers or variable speed pumps or compressors, a type B differential is recommended.

MINIMUM CLEARANCE AROUND THE UNIT

Figure below shows the required clearances and service access around the unit.

NOTE: Ensure the fresh air inlet does not face prevailing wind direction

- In general, the air inlet and outlet should not be obstructed.
- It is also important that there are no obstructions above the fans of the unit.
- Make sure that the fresh air duct is not in the same direction as the prevailing winds.
- If machine is including gas burner, minimum clearance around the unit must be at least 8 m to allow a proper gas flue dilution. If not possible, the fresh air intake must be ducted at least 8 m away from the gas burner exhaust.
- In case of extraction option, it is recommended to duct fresh air intake. In order to ensure good air quality, it is recommended to separate fresh air and exhaust air by at least 8m.
- An approach ramp must be installed if the unit's installation requirements tell that it's necessary to reach the main switch, the electrical cabinet, the compressor and the ventilation compartment. This recommendation is valid for all type of installations.
- It is also important to respect a minimal clearance of 3 meters above of the unit, to allow a good operation of the outdoor fans.
- If you have any questions about the implementation, please contact us so that we can assist you.

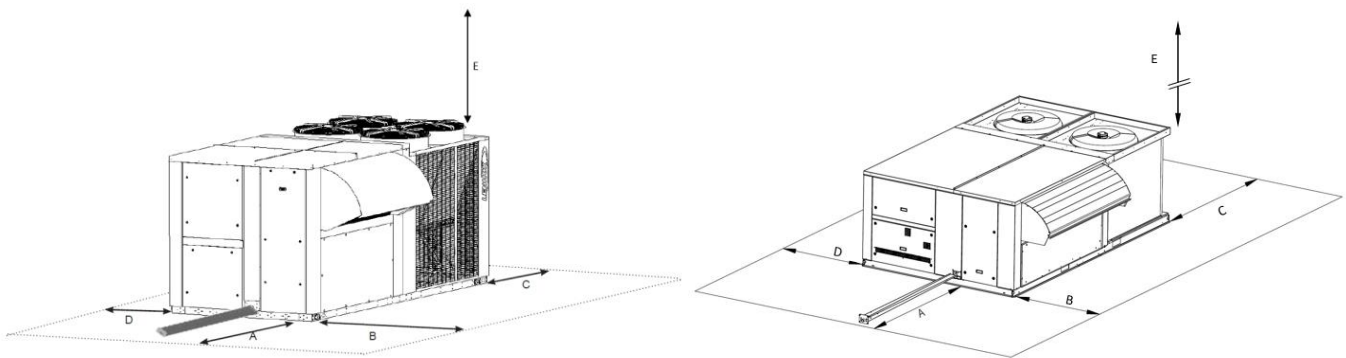

Unit	Size	A	B	C	D	E
		(mm)				
C BOX	35-45	3000 (1)	3000	3000	3000	3000
D BOX	55-65	3000 (1)	3000	3000	3000	3000
E BOX	75-85	3000 (1)	3000	3000	3000	3000
E+ BOX	95-115	3000 (1)	3000	3000	3000	3000
F BOX	100-120	3000 (1)	3000	3000	3000	3000
G BOX	130-150	3000 (1)	3000	3000	3000	3000
H BOX	180-210	3000 (1)	3000	3000	3000	3000

(1) Add 1000 mm if the units are equipped with gas burner

RECOMMENDATIONS FOR DUCTS CONNECTIONS

Some rules must be respected for the connections between ducts and unit.

Whatever the supply configuration is, respect a minimal duct's length (D) of 2m before any elbow or any duct's diameter change

Horizontal supply

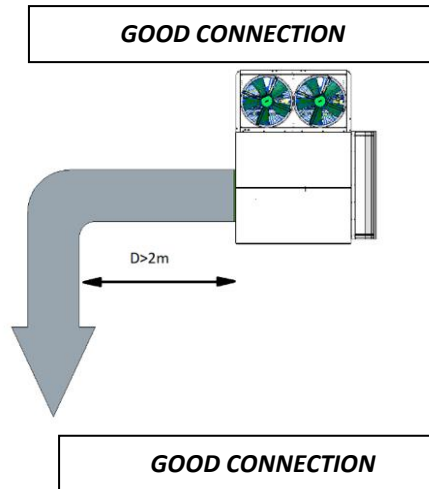
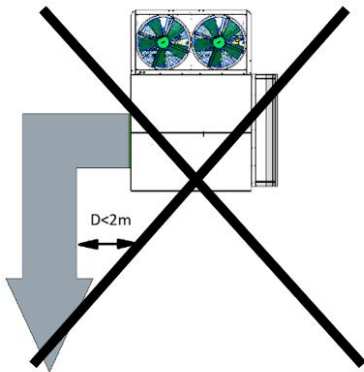

Vertical supply

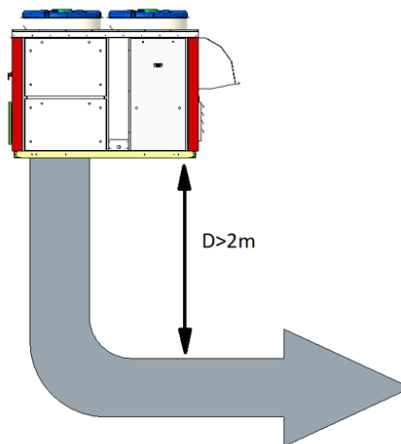
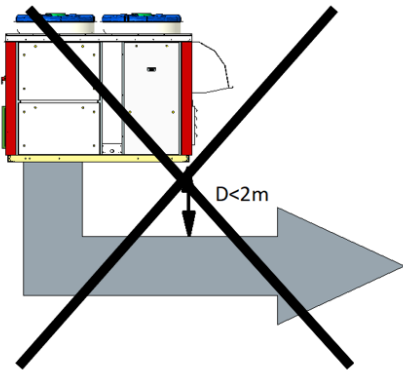

EXTRACTION

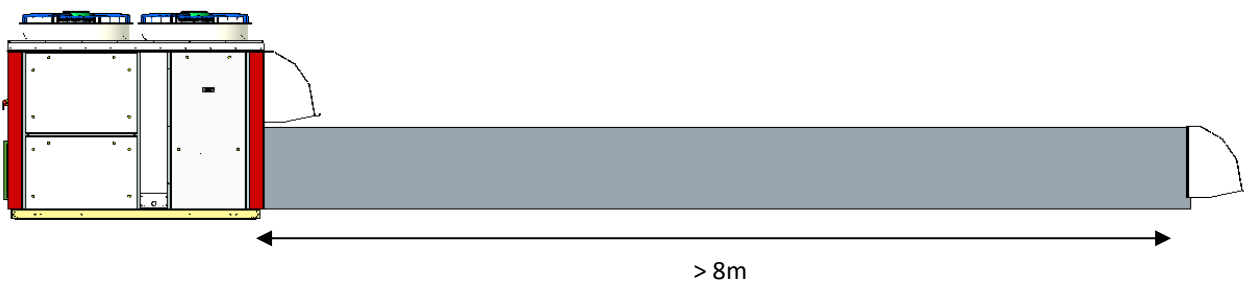

It is recommended to sheath the exhaust air by at least 8m (according to local regulations) to escape the fresh air inlet when the input-output are on the same side.

General remarks:

It is forbidden to walk on the machine.

The machine must not be used to support the ducts.

CUSTOMER WIRING

VERTICAL CUSTOMER WIRING C, D, E, E+ BOX (SIZES 35, 45, 55, 65, 75, 85, 95, 115)

- 1- Remove the indicated plate.

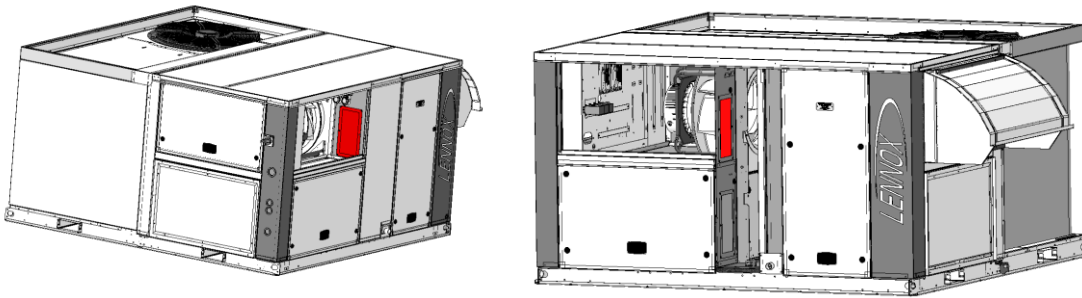

Drill the sheet metal to the diameter of the cable glands
It is recommended to use only one cable per cable gland

- 2- Place the cable glands on the plate.

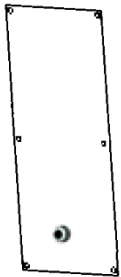

- 3- Wire through the plate.
- 4- Replace the plate.

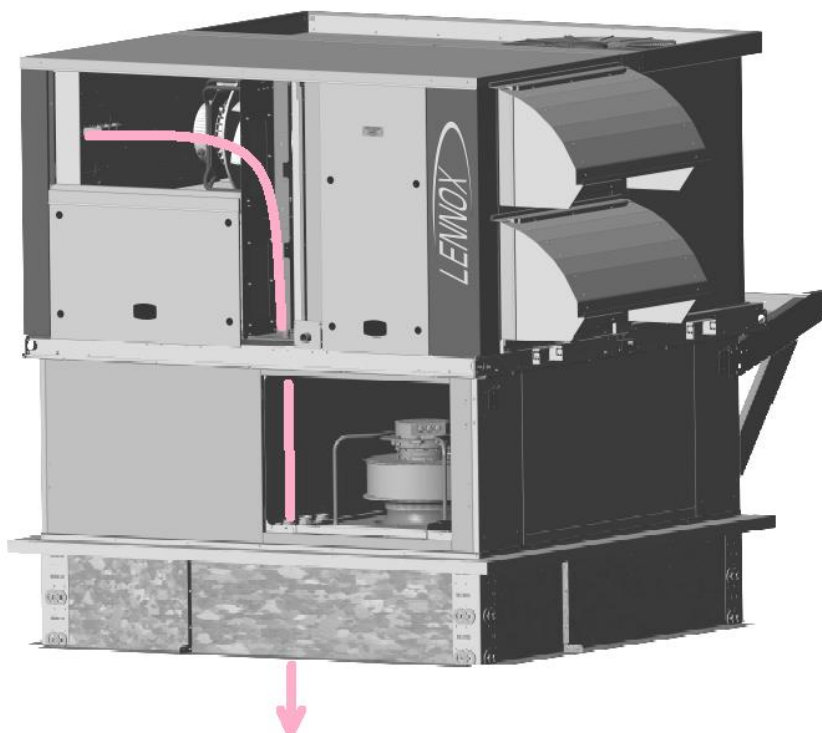

Accessibility for main switch connection on C-Box (SIZES 35, 45)

Accessibility for main switch connection on C-Box (sizes 35-45) In case of full options control panel, the access to connect the power cable to the main switch can be limited. Therefore a removable hatch is available at the back of the control board (accessible from the ventilation panel). When the cable connection is finished, it's important to put the hatch back in its initial position.

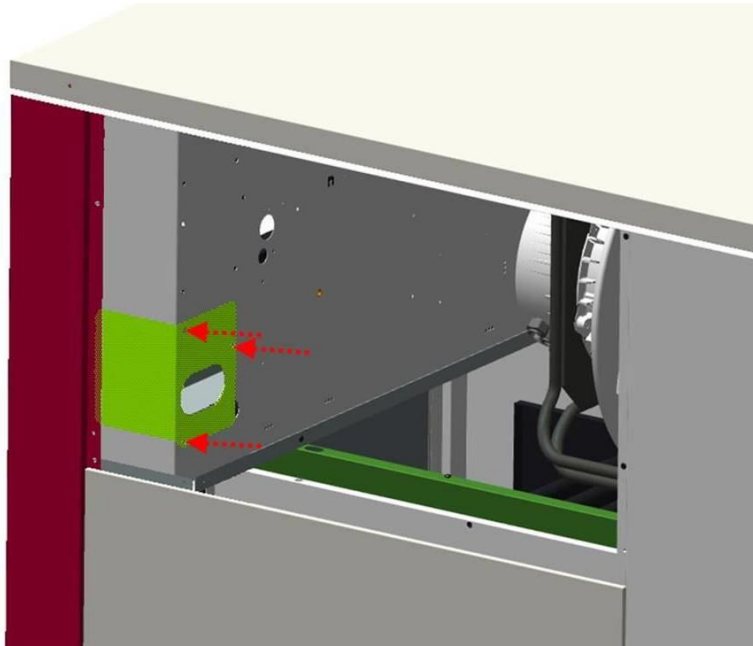

VERTICAL CUSTOMER WIRING F, G, H BOX (SIZES 100, 120, 130, 150, 180, 210)

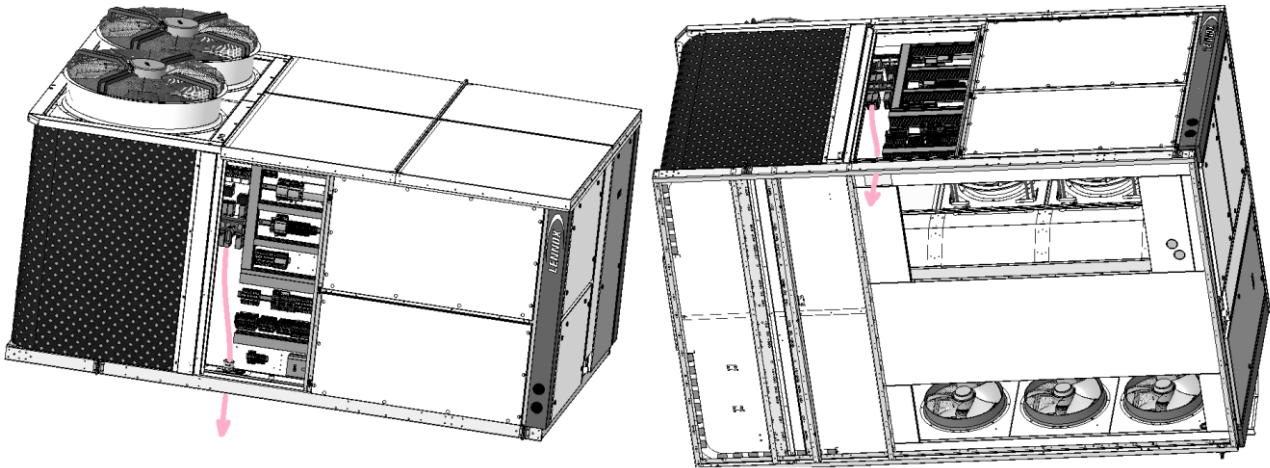

Pass through the cable glands at the bottom of the electrical box.

Drill through the insulation if necessary.

WIRING WITH ROOFCURB WITHOUT EXTRACTION

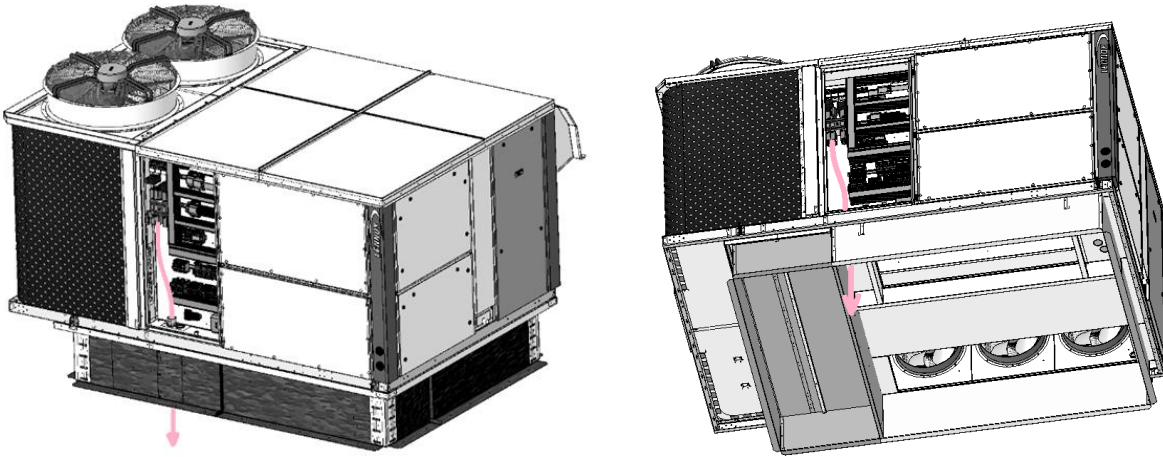

WIRING WITH ROOFCURB WITH EXTRACTION

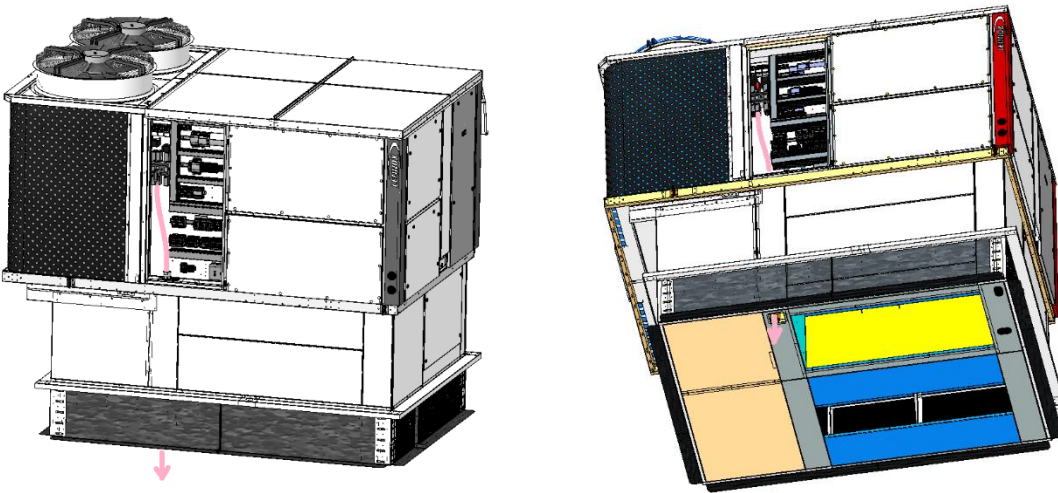

HORIZONTAL CUSTOMER WIRING ON C, D, E, E+BOX (SIZES 35, 45, 55, 65, 75, 85, 95, 115)

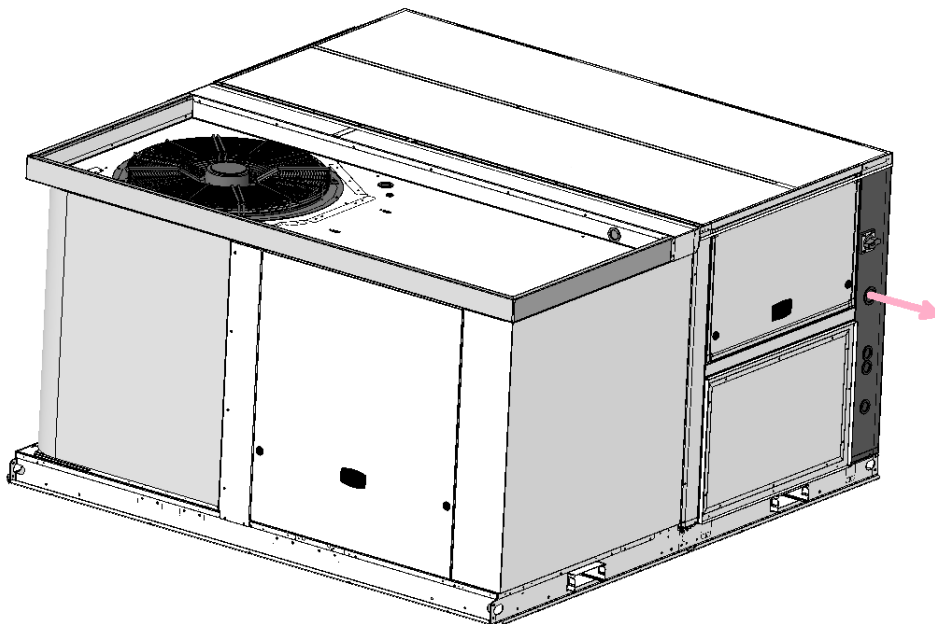

HORIZONTAL CUSTOMER WIRING ON F BOX AND G BOX (SIZES 100, 120, 130, 150) (OPTION)

To horizontally wire a F or G-BOX e-BALTIC power supply, it must be placed on feet.
Do not install the unit on mounts (fixed or antivibration) other than those provided by LENNOX.

1

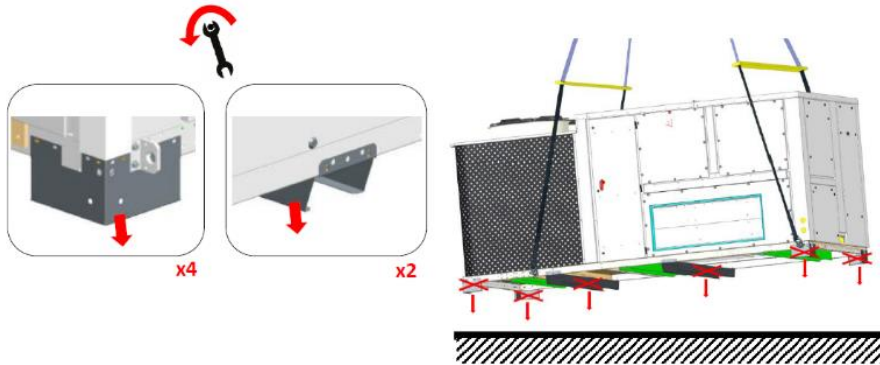

First, remove the 4 transport feet and the 2 sheaths when the e-BALTIC unit is lifted.

2

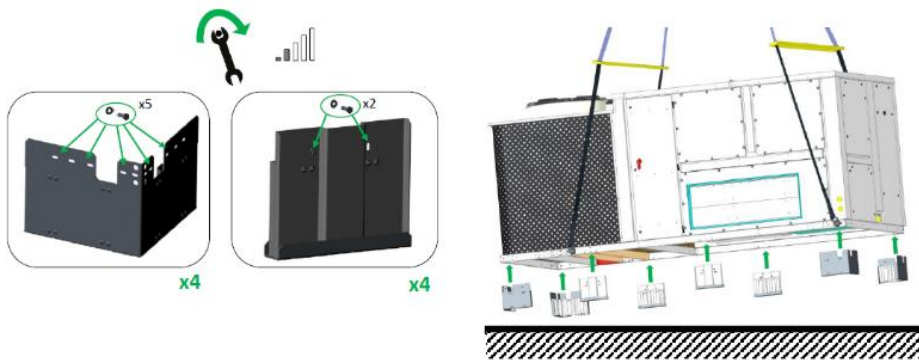

Place the 4 side feet and 4 corner feet (supplied loose) in place of the transport feet and sleeves and tighten moderately with screws and washers.

3

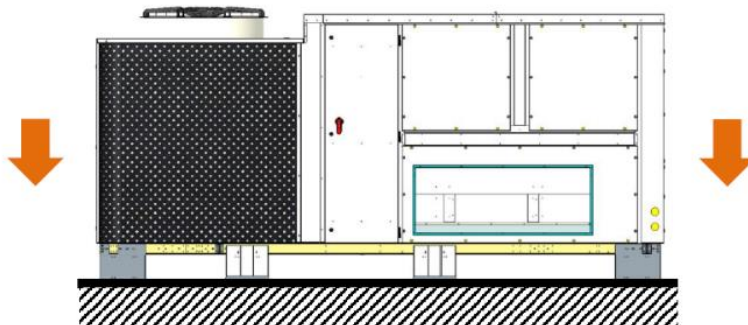

Put the unit on the ground.

4

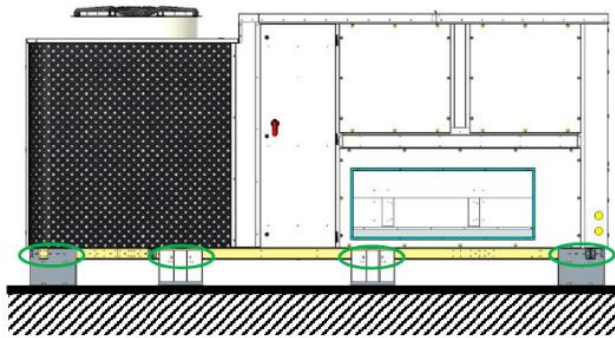

Complete the tightening of the feet screws.

5

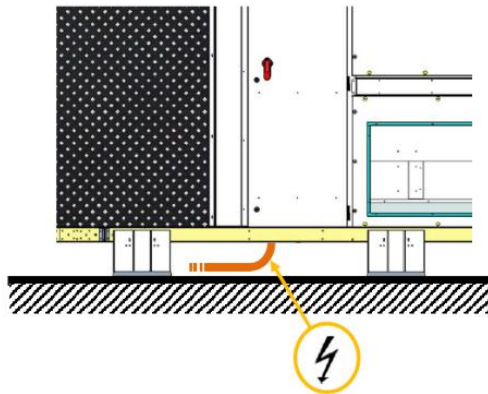

Connect the unit by the bottom as vertical wiring.

CUSTOMER HORIZONTAL CABLING H-BOX (SIZES 180, 210)

To horizontally wire a H-BOX e-BALTIC power supply, place metal cable glands in front, under the electrical cabinet.

- 1- Remove the indicated plate.

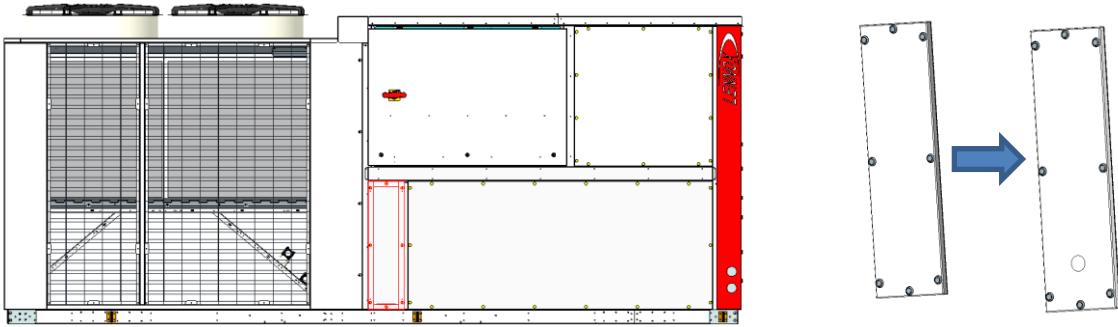

- 2- Drill the sheet to the diameter of the cable glands.
It is recommended to use only one cable per cable gland.
WARNING: cable glands must be in metal and not in plastic.

- 3- Place the cable glands on the plate.

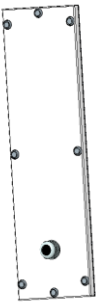

- 4- Wire through the plate.

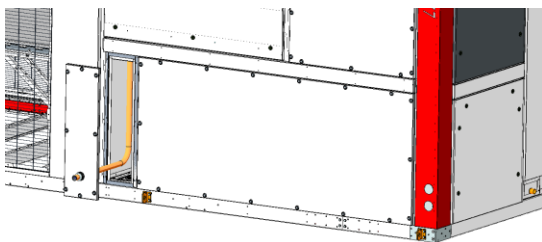

- 5- Replace the plate.

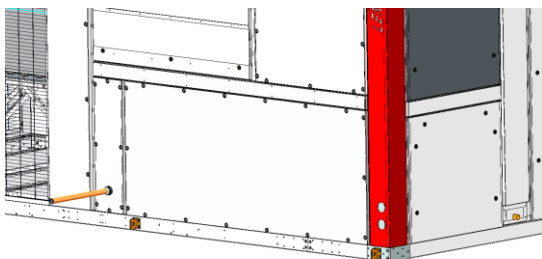

INSTALLATION ON A ROOFCURB

TYPE OF ROOFCURB

Non adjustable roofcurb

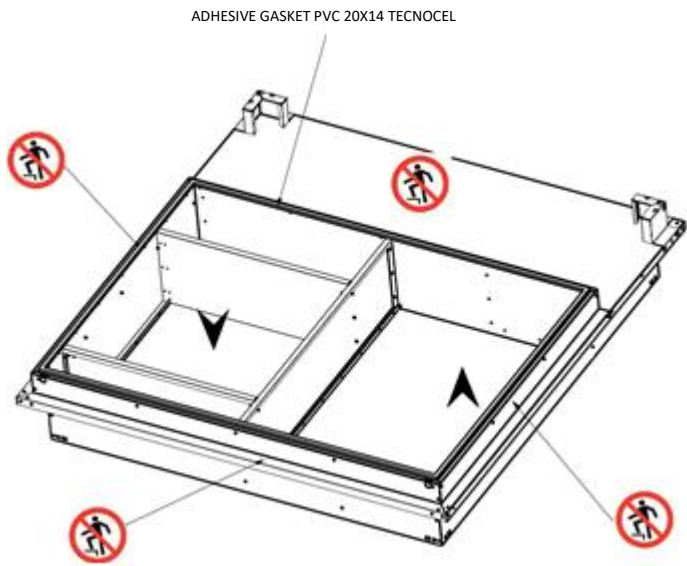

Adjustable roofcurb

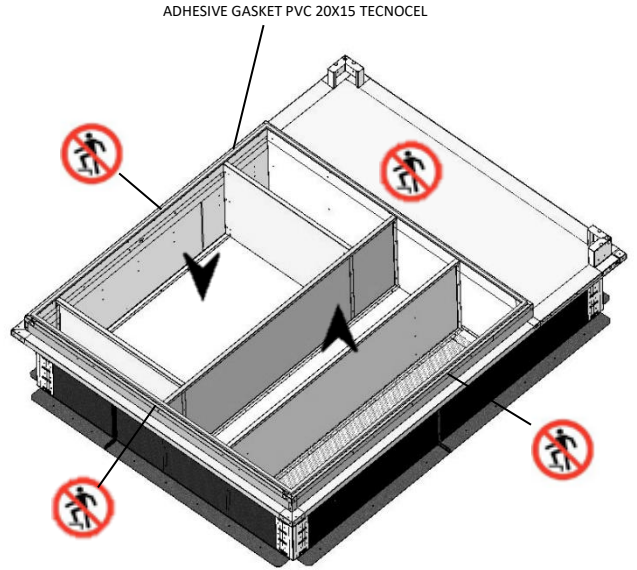

Exhaust roofcurb

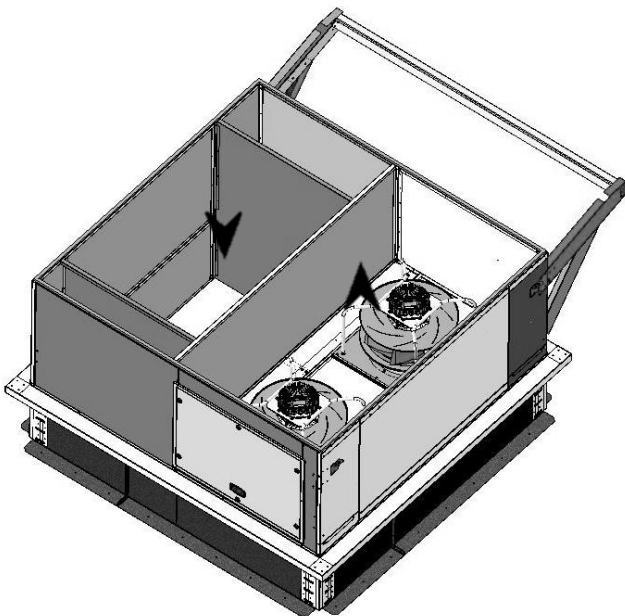

Multidirectional roofcurb

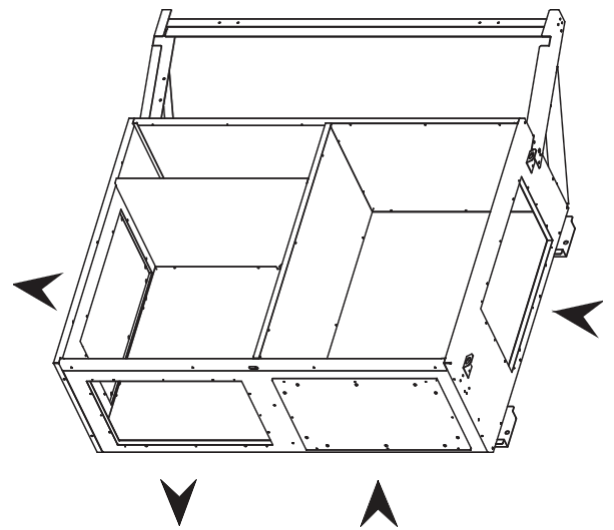

WARNING : a multidirectional flowcurb and horizontal extraction flowcurb must be secured to the ground using existing fixing holes on the frame.

WARNING : a roofcurb must be strongly secured to the ground. The contact to the ground must be realized with the entire contact area of the roofcurb (no discontinuous contact).

INSTALLATION ON AN ADAPTABLE ROOFCURB

CAUTION:

- Installation of the unit and accessibility must be compliant with the local regulations. Ensure that all access equipment allow maintenance operation in safety (electrical cabinet, main switch, panels, filter, refrigerant circuit...); this recommendation is valid for installations in general and in particular for return and curbs.
- It's advised to fix curbs and roofcurbs to the unit.

Above all, ensure that all the adjustable returns are facing outward. They are usually turned inside-out for transport.

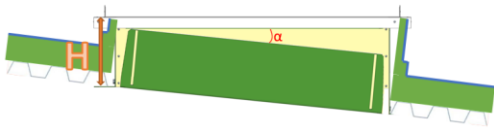

If $H < 430\text{mm}$ and $\alpha < 10^\circ$: Position in position A:

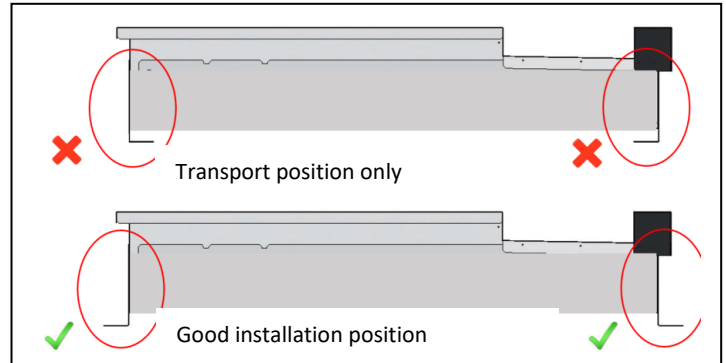
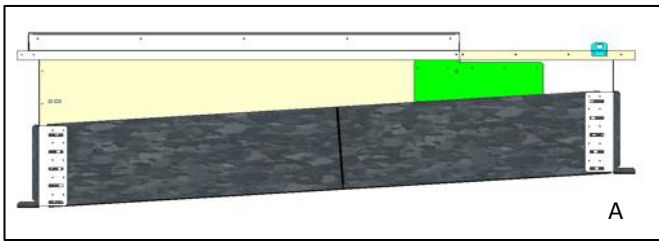

If $H > 430$ or $\alpha < 10^\circ$: Position in high position B

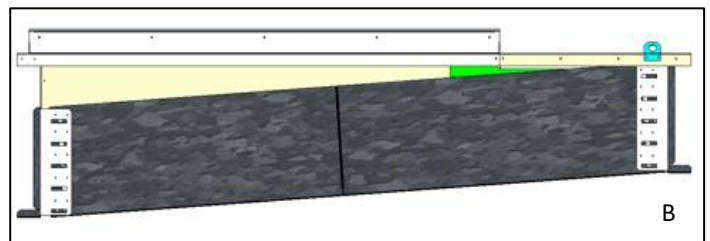

Place the roof mounting frame on the trimmer beam by first lining up the inlet and the outlet opening.

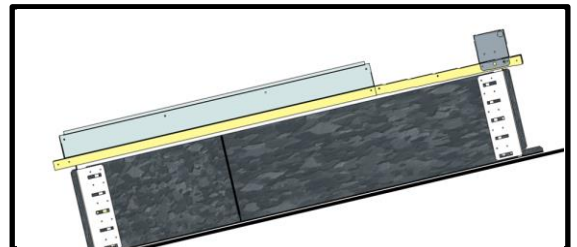

After levelling the frame, secure the adjustable returns on the trimmer.

It is important to center the unit on the roof frame

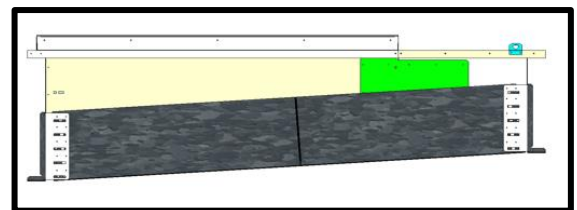

When the frame is correctly positioned, it is essential to secure the assembly with a disconnected stitched welded seam (20 to 30 mm every 200mm) or M6 self-taping screws in pre-drilled holes along the outside:

Example with welded seam

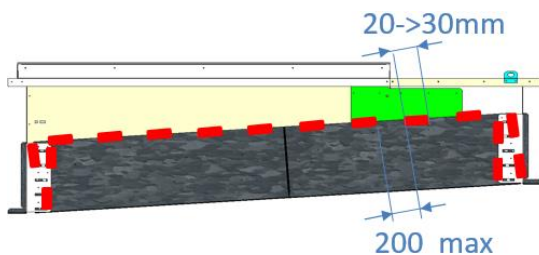

Example with screws

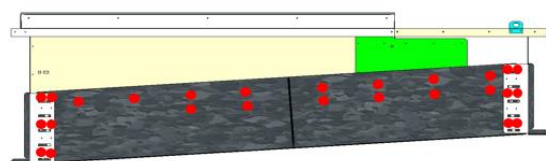

CURBING AND FLASHING

Check that the insulation is continuous, counter flash and seal around the frame as shown

CAUTION: To be effective, the upstream must end below the drop edge. Where pipes and electrical conduits extend through the roof, flashing must conform to local codes of practice

Before installing the equipment, make sure that seals are not damaged and check that the unit is secured to the mounting frame. Once in position, the bottom of the equipment must be horizontal. The installer must comply with local authority standards and specifications.

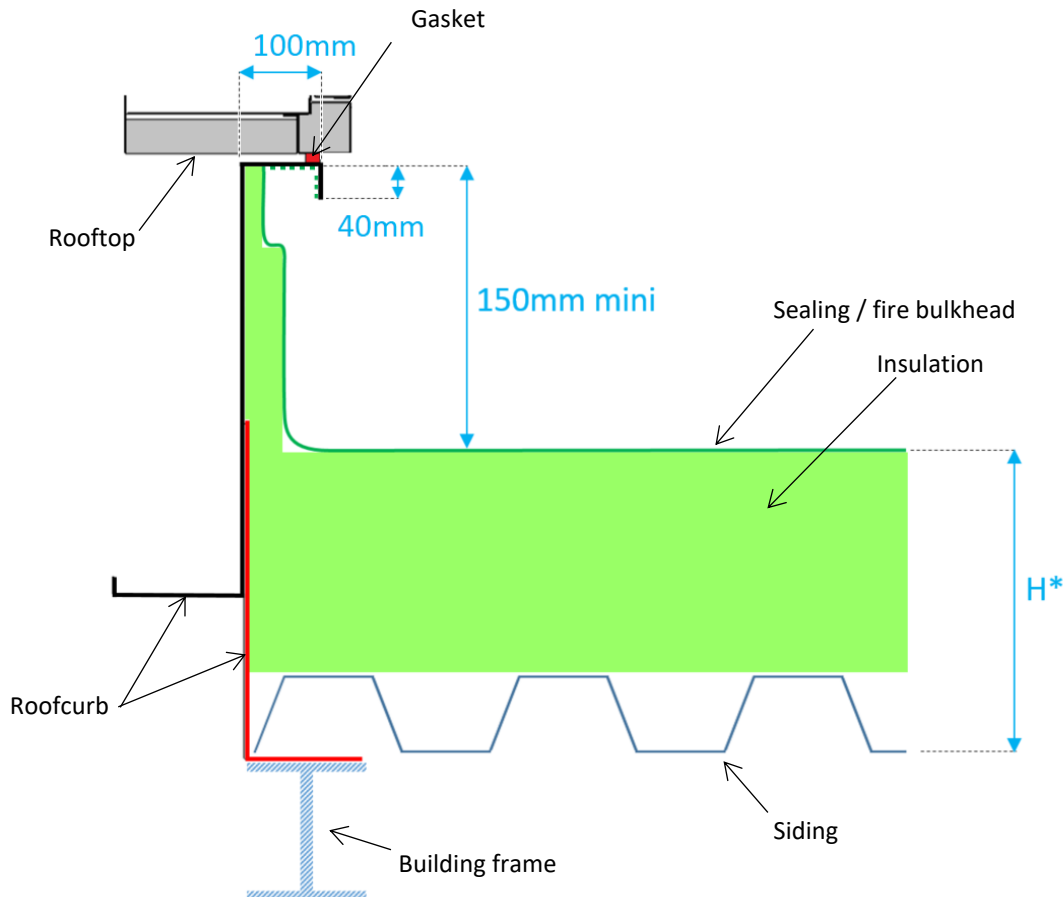

* Check that the roofcurb height is enough to respect a sealing height of 150mm minimum (French DTU 43.3) considering the building specifications: geometry of the roof, material and thickness of the insulations and other protection layers, slope of the roof...).

NON-ADJUSTABLE NON-ASSEMBLED ROOFCURB INSTALLATION

The roof mounting frame provides support when the units are installed in down-flow configurations.

The non-adjustable, non-assembled roof mounting frame can be installed directly on decks having adequate structural strength or on roof supports under deck.

NOTE: frame assembly must be installed flat, leveled within 5mm per linear meter in any direction

SIZE C, D, E, E+ BOX (SIZES 35, 45, 55, 65, 75, 85, 95, 115)

FRAME PARTS PACKING

Different parts are used in the assembly of this roof mounting frame. There are delivered stacked on a pallet. During assembly, all parts must be sealed with a polyurethane sealant.

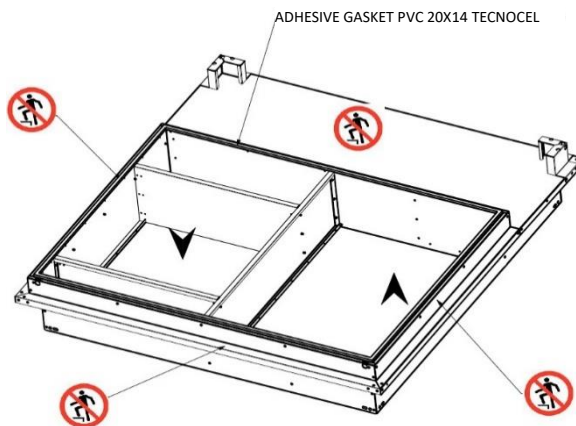
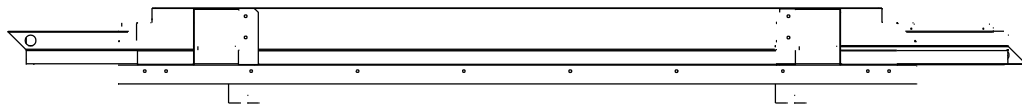
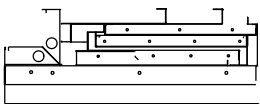
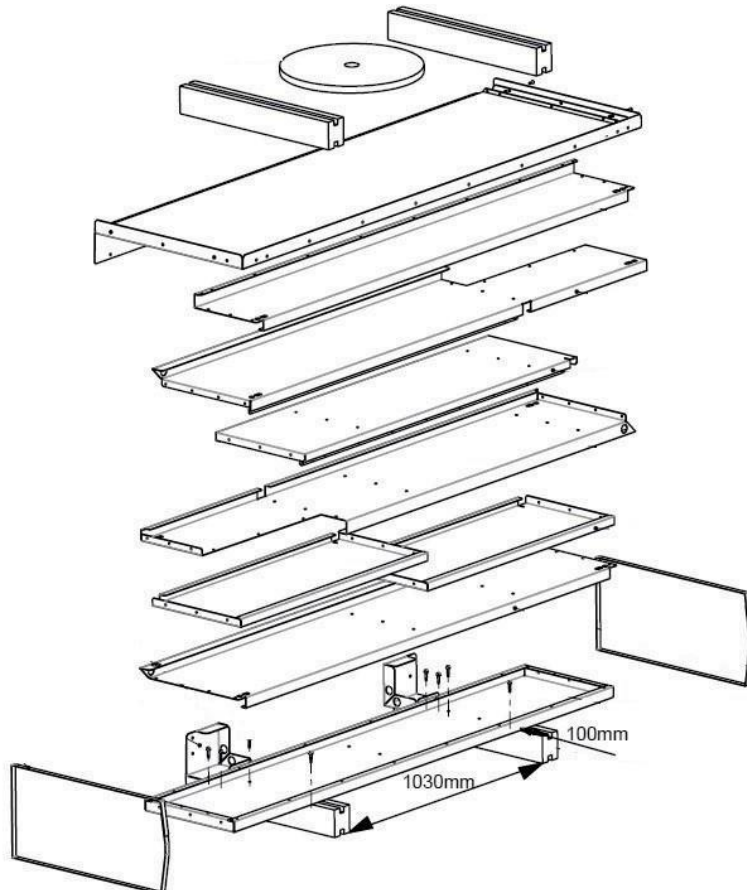

ASSEMBLY

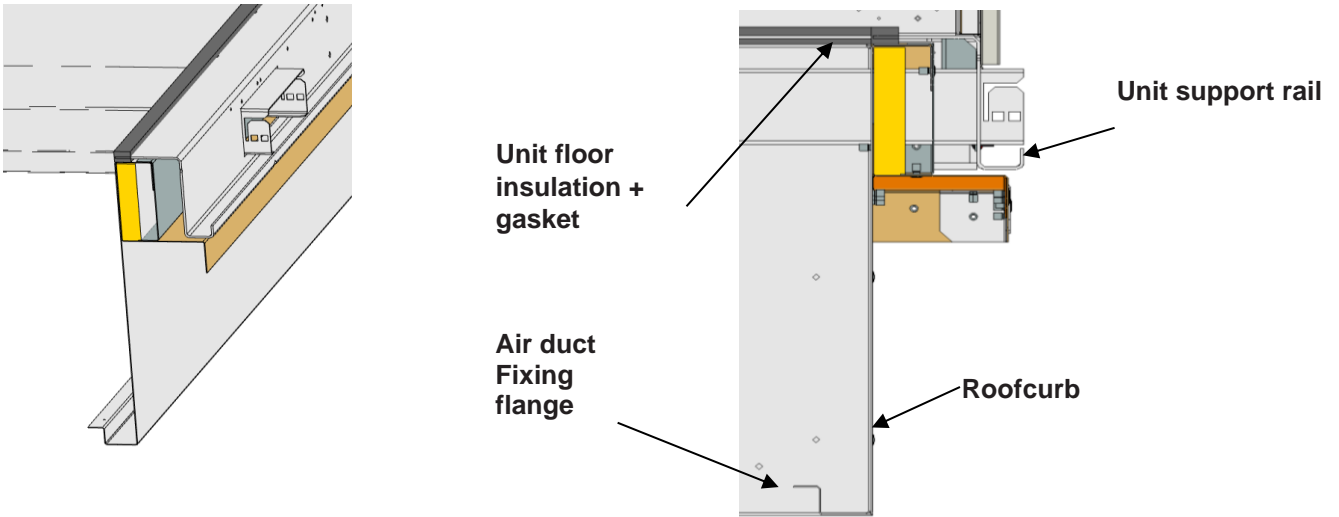

SIZE F, G, H BOX (SIZES 100, 120, 130, 150, 180, 210)

FRAME PARTS PACKING

Figure below shows the different parts used in the assembly of this roof mounting frame.

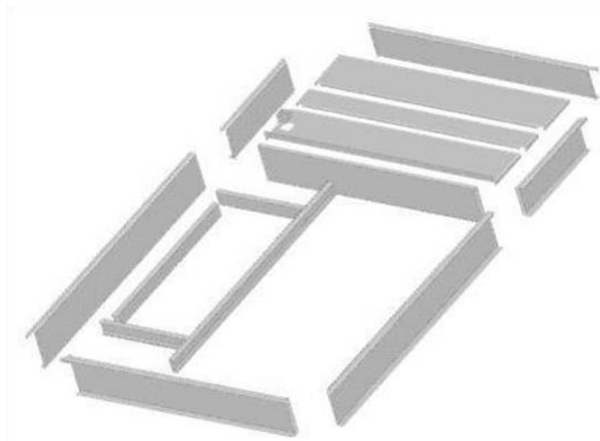

SECURING THE FRAME

To ensure proper mating with units, it is mandatory that the roof mounting frame be squared to roof structure as follows:

- With frame positioned levelled in the desired location on roof trusses, tack weld corner of frame.
- Measure frame diagonally from corner to corner as shown above. These dimensions must be equal in order for the fame to be square.
- It is extremely important to sight frame from all corner to ensure it is not twisted across. Shim frame under any low side. The maximum slope tolerance is 5mm per linear meter in any direction.
- After the frame has been squared, straightened and shimmed, weld or secure the frame to the roof deck. NOTE: It must be securely fastened to the roof as per local codes and regulations.

TRANSITION CURB

This roof curb will arrive as a packaged on a pallet and need to be built together.

The part will be connected by special corrosion free nails. It is not possible to connect with standard nail equipment because there is a lot of power needed. Therefore, you need a pneumatic or electric device

WARNING: all the roofcurb must be strongly secured to the ground

The contact to the ground must be realized with the entire contact area of the roofcurb (no discontinuous contact).

All parts must be sealed with polyurethane sealant during assembly.

FOAM INSULATION INSTALLING (C,D,E,E+) (SIZES 35, 45, 55, 65, 75, 85, 95, 115)

- Stick large foam pieces underneath the flat top

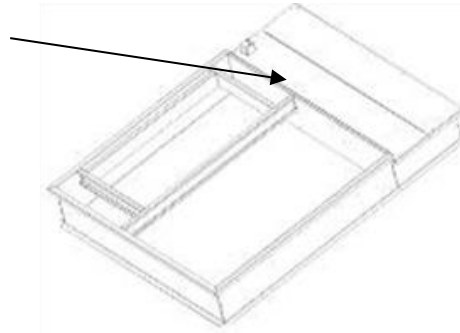

FOAM GASKET INSTALLING (C,D,E,E+)(SIZES 35, 45, 55, 65, 75, 85, 95, 115)

- Stick gasket all around the curb flange’s top

Let it free on 200 mm long to enable water drainage

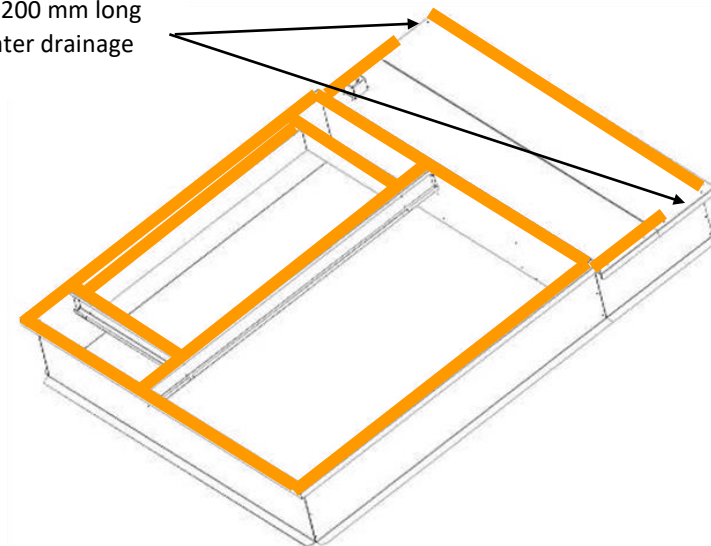

ELECTRICAL CONNECTION

The extraction curbs are fitted with an extraction fan and a pressure sensor used to measure the flow of extracted air. The pressure sensor is directly connected to the first fan of the curb. The fan must be connected to the rooftop machine which is placed on the curb. This connection must be made once the machine is installed on the curb. A waiting wiring harness in the energy-saving compartment of the machine must be pulled to the terminal box on the curb intended for connection. For cable routing and connection to the terminal box, refer to the plan of the curb and the electrical diagram supplied with the machine.

NON-EXTRACTION ADJUSTABLE ROOF CURB INSTALLATION

The adjustable roofcurb without extraction can be installed directly on the platform with the appropriate structural resistance or on the roof supports, under the platform.

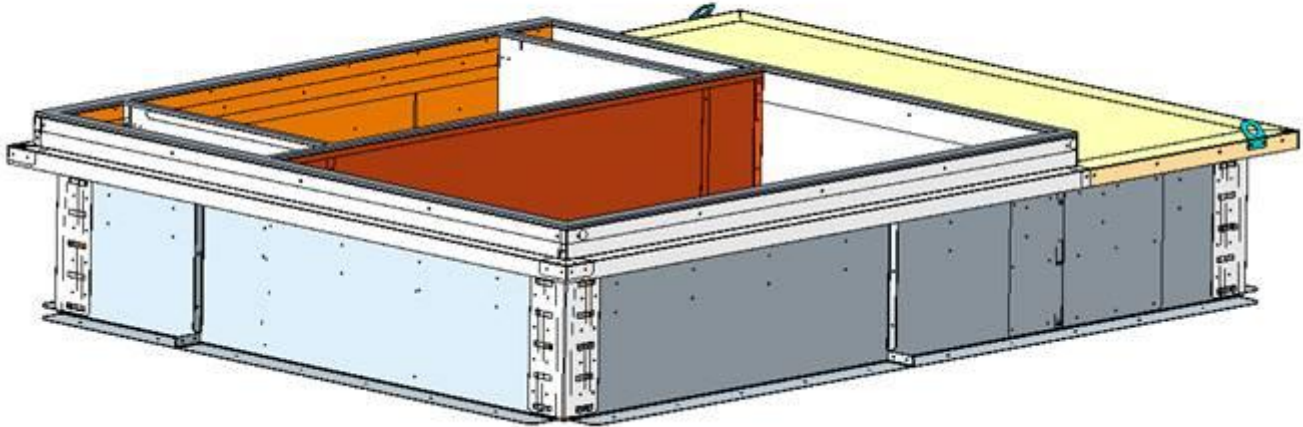

SPECIAL CASE OF ADJUSTABLE ROOFCURB WITHOUT EXTRACTION

F-G-H BOX (SIZES 100, 120, 130, 150, 180, 210)

F-G-H BOX roofcurbs are supplied with screwed rings.

They must be removed, then turned over and mounted on the back of the sheet to prevent the rings from touching the unit and to keep the rings for reuse.



HEAT RECOVERY

GENERAL DESCRIPTION

Heat recovery modules (HRM) have following interests:

- in winter season and heating mode, the heat in the extract air is exchanged with the fresh air ;
- in summer season and cooling mode, the heat of the fresh air is transferred to the extract air.

HRM are two plates heat exchanger modules, that differ from each other by their horizontal (HRMH) or vertical (HRMV) configuration.

TRMO is a thermodynamic heat recovery module, included in the machine. Its main interests are:

- a variable fresh air rate from 25 to 100%,
- a high COP in winter when pre-heating the fresh air due to a favorable evaporating temperature, especially with high air flow rate;
- a high EER in summer when pre-cooling the fresh air due to a favorable condensing temperature, especially with high air flow rate.

For those reasons, TRMO will be more suitable than HRMV/HRMH in areas where the difference between indoor temperature and outdoor temperature is low. For example, in Mediterranean areas, where winter temperatures are not very cold or summer temperatures are not very high.

ELECTRICAL CONNECTIONS OF THE HEAT RECOVERY UNIT

Two components have to be connected in the space between the plate heat exchanger and the economizer:

- For the air pressure switch, connect and tighten the 2 spade-tips on terminal 1 and 3 (no polarity):
- For the actuator, assemble the two parts of the connector:

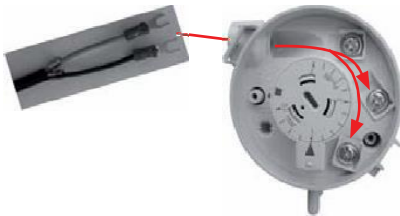

HEAT RECOVERY INSTALLATION C, D, E BOX (ERVF + HRMV) (SIZES 35, 45, 55, 65, 75, 85)

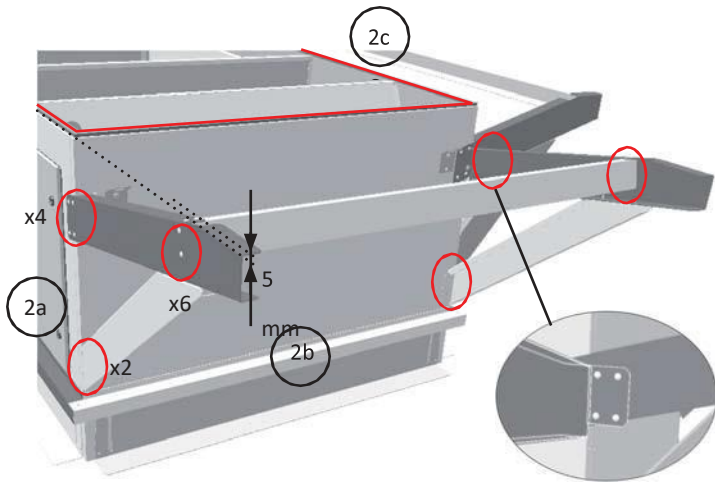

1. Install the flowcurb.
2. Before installing the rooftop
 - a. Fix the brackets (5 pieces) on the curb by 24 screws(6x16mm);
 - b. ADJUST the position of the attachment bracket so that it is 5 mm above the support surface (without the foam);
 - c. Install the foam (25x10 mm) on the upper part of the flowcurb.

3. a. Fix the lower mounting bar of the heat recovery module using 4 screws (6x16 mm) and remove the side doors;
- b. Make sure that the foam is not damaged (20x15 mm).
4. Install the rooftop and remove the lifting covers.

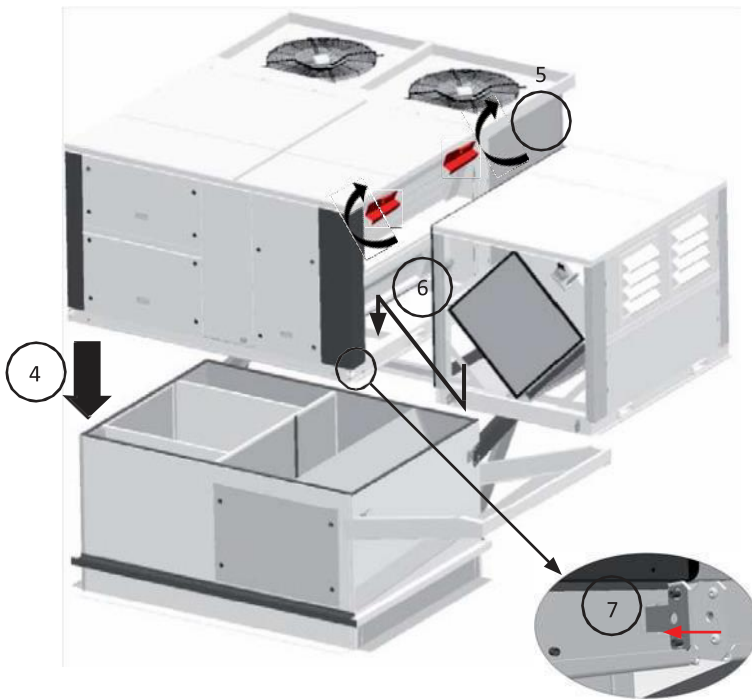
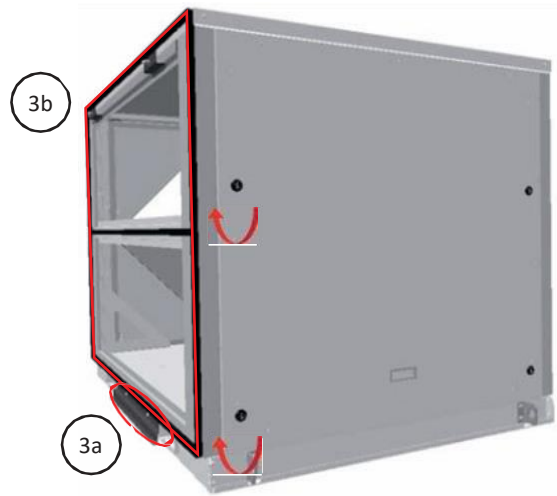

5. Place the two upper mounting bars through the two top slots.
6. Install the heat recovery module on the bracket by taking care to position properly the lower mounting bar.

Don't forget to remove the lifting covers from the module.

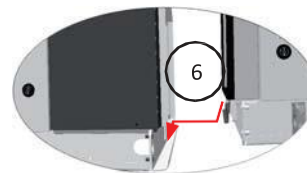

7. Slide the 'T' plate into the lifting lug and place the bolt through it. On the opposite side, place also the bolt (detail A).

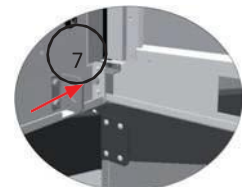

Détail A

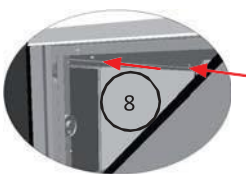

Détail B

8. Finally tighten the heat recovery module with the 4 bolts 8x60mm to compress the foam (2 bolts on the upper mounting bars (detail B) and the 2 bolts placed in step 7).

THERMODYNAMIC HEAT RECOVERY C,D, E, E+BOX (SIZES 35, 45, 55, 65, 75, 85, 95, 115)- INSTALLATION
REFRIGERATION CIRCUIT

Frigorific components access:

Compressor is located in the fix condenser part. Its access for electrical checking and pressure taps (HP and LP) is made through the screwed access door behind the hinged coil.

4-way valve, thermostatic expansion valve, dryer, and sensors are located on the e-Drive™ supply compartment.

Electrical components:

- For D and E-box, specific TRMO components are located in the electrical box.
- For C-box, specific TRMO components are located on the back of the electrical box, and can be accessible from the supply e-Drive™ compartment.

COMMISSIONING
Electrical connections:

- All wire connections are factory made.

Starting up:

- CLIMATIC™ configuration:
 - Power the unit
 - Check the configuration of the CLIMATIC™ with the DS in expert mode.
- Flow rate settings:

Make sure that both supply and exhaust air flow are balanced. See section EBHO or ERVF. Balancing is correctly set if:

 - with Test = 'B.Nom 100%': at 100% fresh air, set the exhaust Flow 3864 = supply flow 3333;
 - then switch Test = 'B.Nom 0%':
 - reduce coefficient 3866 until the louvers are closed;
 - then if the flow (supply and exhaust) is far from the previous flow settings, set coefficient 3335;
 - finally, repeat step 1 and 2 to obtain a constant flow whatever the fresh air mode.
 - same settings have to be realized for reduced flow - 3334 and 3865.

WARNING! During the settings, wait until the economizer is fully closed or opened, since it takes 1-2 minutes to switch.

- Start the TRMO circuit (circuit 3): switch Test='C3--Cool'
 - check the sense of rotation of the circuit 3 compressor;
 - check frigorific values (HP, LP, overheating and subcooling).
- Repeat the last operations with Test='C3--Heat'

SERVICE DIAGNOSTIC

REFRIGERATION

Fault	Possible causes and symptoms	Solution
Low LP and LP cut out	Alarm 317: main frigorific issue	Lack of charge, obstructed components
	Alarm 327: too low LP	Freezing: wait that coil is defrosted by exhaust air; Air flow too low on evaporating side (too low speed rate / fouled filter or coil).
HP problem and HP cut out	Incorrect airflow rates	Check fan (exhaust or supply) function of the mode (Amps) and also filter.
	Refrigerant charge too high	Check the refrigerant charge load according to the refrigerant load table.
See also frigorific diagnostic of BALTIC™ section 'Refrigeration'.		

INDOOR OR EXHAUST FAN BLOWER:

For both indoor supply fan and exhaust fan, same faults, causes and solutions are expected. See diagnostic of 'Indoor fan blower'.

HEAT RECOVERY CONTROL

CONFIGURATION

Configuration of CLIMATIC™ with the DS in expert mode for TRMO (with a modulating exhaust fan):

3813 RECOV. = Comp. for TRMO

3815 EXHAUST = Modulate for both ERVF & EBHO

3816 KIT

3817 Motor } to be checked function of your need

3818 Fan }

USE

Protection :

- Operating envelop Protection: compressor stopped during 6 minutes.
 - 328: min HP = 20.5°C condensation;
 - 329: max HP = 62°C condensation;
 - 319: min LP = between -24.5°C and 1.6°C (function of the condensation temperature) during 5 min => freezing or air flow on evaporator issue;
 - 327: max LP = 26°C.
 - 317: limit LP -27°C during 120 sec => frigorific failure (lack of refrigerant /closed components)
- Anti-freezing Protection consist in defrosting the exhaust coil in heating mode with the extract air.

Control

- No specific parameters have to be set for TRMO control.
- Operation:
 - TRMO runs if there is heating or cooling needs;
 - above 50% fresh air, TRMO compressor has priority to start;
 - under 15°C return or under 20% fresh air, TRMO compressor is not authorized to start.

ENERGY RECOVERY INSTALLATION (ERV+HRMV) ON UNITS E+ BOX (SIZES 95, 115)

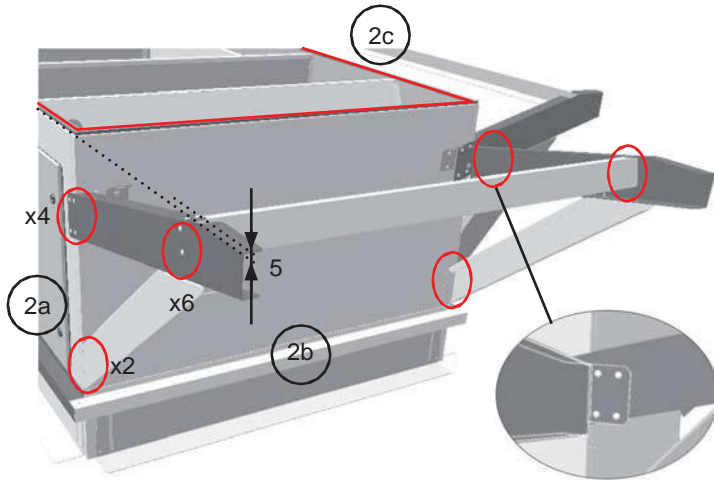

1. Install the flowcurb
2. Before installing the rooftop:
 - a. Fix the brackets (5 pieces) on the curb by 24 screws (6x16mm);
 - b. ADJUST the position of the attachment bracket so that it is 5 mm above the support surface (without the foam);
 - c. Install the foam (25x10 mm) on the upper part of the flowcurb.

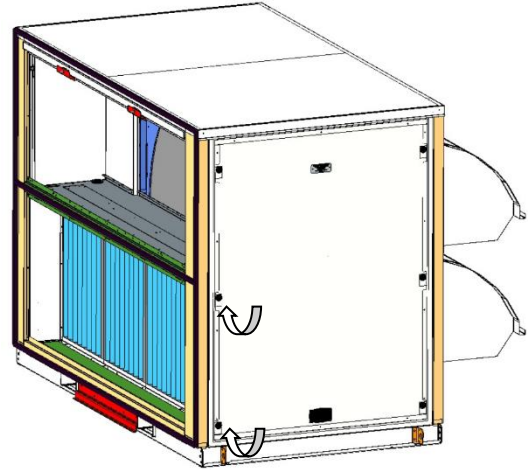

3. a. Fix the lower mounting bar of the heat recovery module using 4 screws (6x16 mm) and remove the side doors;
 - b. Make sure that the foam is not damaged (20x15 mm).
4. Install the rooftop and remove the lifting covers

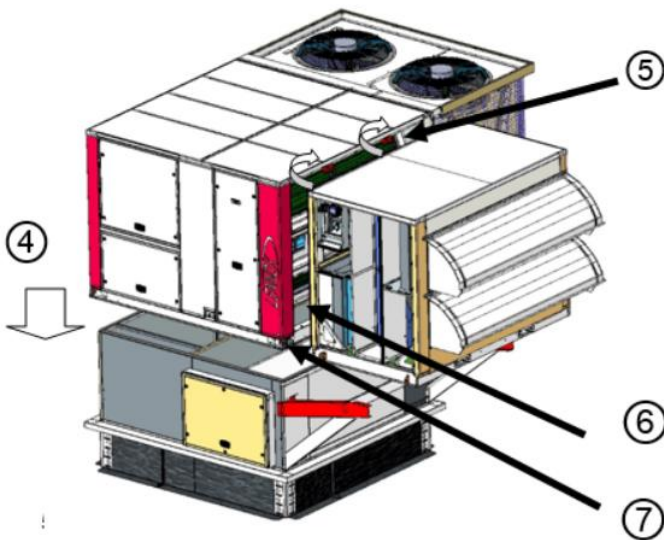

5. Place the two upper mounting bars through the two top slots.
6. Install the heat recovery module on the bracket by taking care to position properly the lower mounting bar

Don't forget to remove the lifting covers from the module.

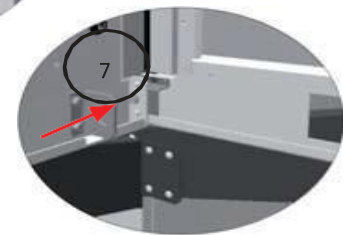
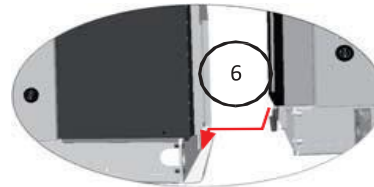

7. Slide the 'T' plate into the lifting lug and place the bolt through it. On the opposite side, place also the bolt.



8. Finally tighten the heat recovery module with the 4 bolts 8x60mm to compress the foam (2 bolts on the upper mounting bars (detail) and the 2 bolts placed in step 7).

ENERGY RECOVERY INSTALLATION ON UNITS F, G, H BOX (SIZES 100, 120, 130, 150, 180, 210)

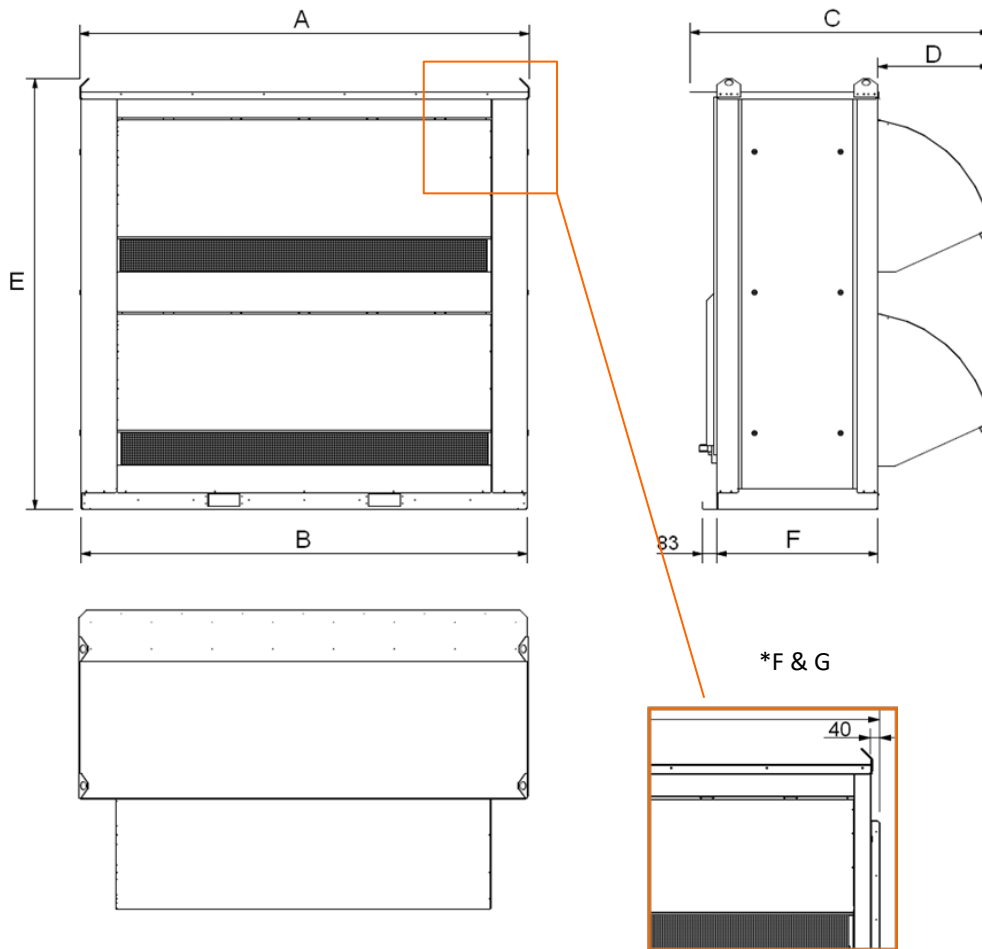

SIZE		DIMENSIONS (mm)						WEIGHT
		A	B	C	D	E	F	
F-box	100-120	2146*	2063	1422	367	1796	900	525 kg
G-box	130-150	2330*	2247	1518	463	2170	900	635 kg
H-box	180-210	2516	2497	1676	623	2418	900	730 kg

STEP 1: SUPPLIED ROOFTOP CONFIGURATION



Remove lifting lug
Remove corner sheet metal

STEP 2: LIFTING

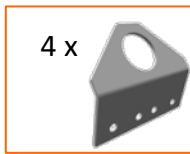

STEP 3: FITTING

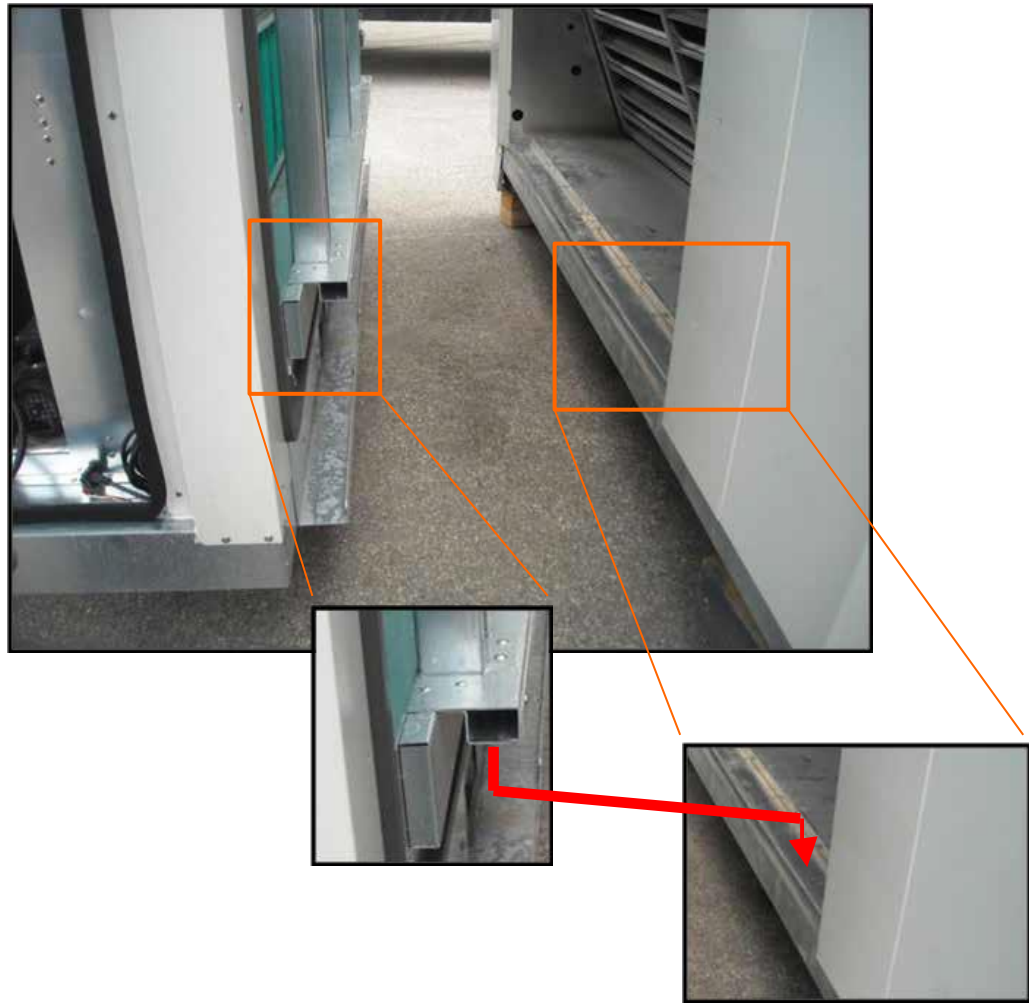

STEP 4: CHECK



STEP 5: FIXING

H-box (180, 210) : for each side:



H=10
x Ø4,8 x 32mm

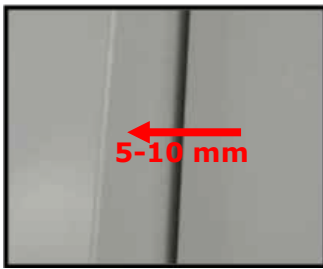

F & G-box (100,120,130,150): for each side:



F = 8
G = 8



X Ø 4, 8 x 25 mm

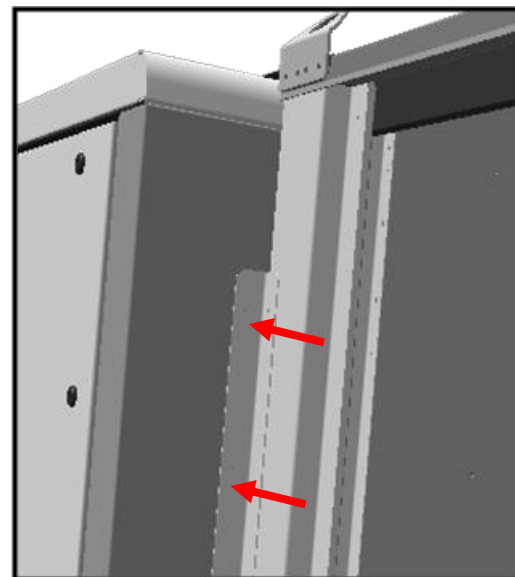

On top



F (100,120) = 13

G (130,150) = 15

H (180,210) = 15



X Ø 4, 8 x 25 mm

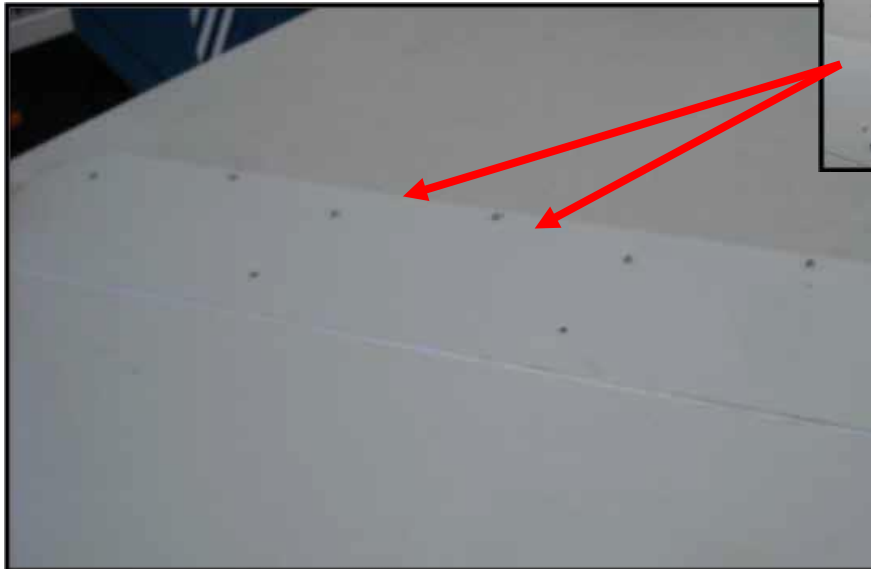

STEP 6: MASTICATE

Apply mastic on side junctions
and higher junction



STEP 7: ELECTRICAL WIRING

The Recovery module is sent with a power cable and a T-lan cable:

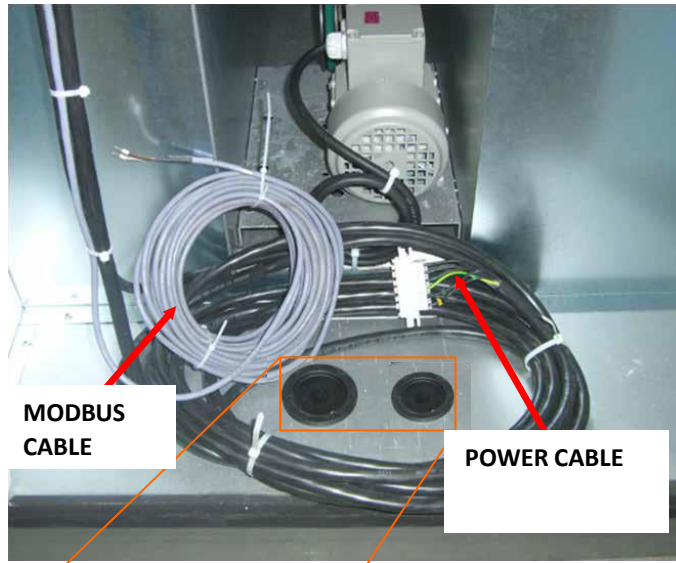

Separate these 2 cables (communication and power ones) using the two holes.

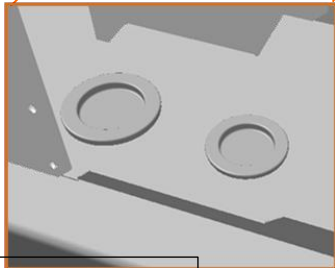

Then, attach the 2 cables to the grid of the extraction curb and insert them into the rooftop electrical panel.

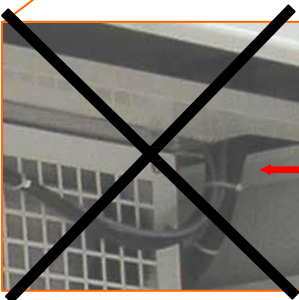

Communication and power cables from the module should be separated

Then connect the power cable from the module to the rooftop, and the Modbus cable according to the bus connection wiring diagram (it could be connected to the BE (A1) connector in electrical rooftop panel or other options with bus communication):

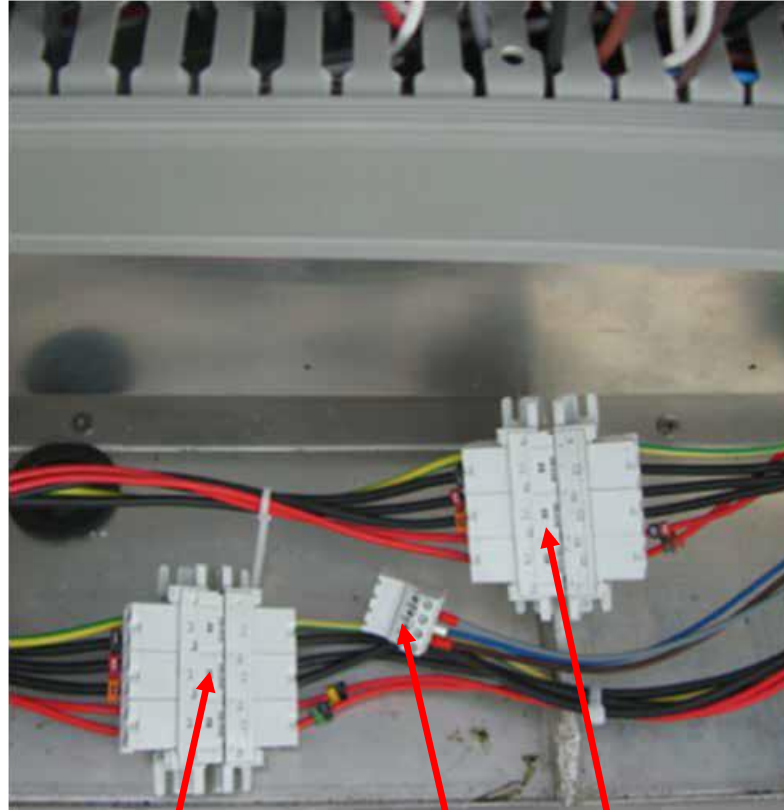

Recovery module connexion

Extraction roofcurb connexion

Actuator roofcurb connexion

BE CAREFUL

Check connections and connect male connections to good female one. Roofcurb and recovery module connectors are the same

To check the wiring, please refer to Rooftop and Recovery Module electrical diagram.

STEP 8: ROOF CURB ECONOMIZER ADJUSTMENT

With Heat Recovery module option the extract air goes through the wheel, that's why the economizer of the roofcurb has to be permanently fully closed.

If roofcurb economizer is not fully closed, close it manually



And don't connect the actuator to the rooftop

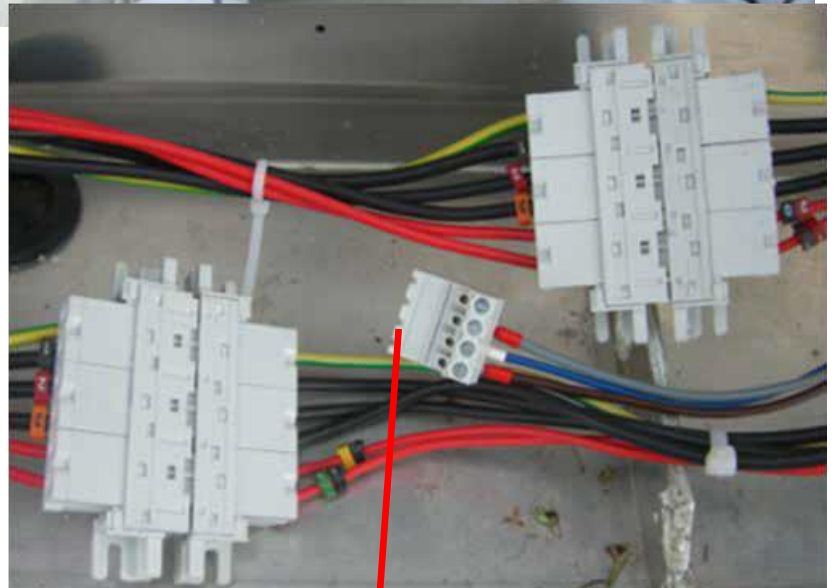

**ACTUATOR ROOFCURB
NOT CONNECTED**

SENSOR MOUNTING

CO2 OR ADVANCED ENTHALPIC CONTROL PACK SENSOR

The probe is delivered unassembled on the machine. The installer is responsible for mounting and connecting this sensor.

The device can be installed in dry surroundings (IP20) by screws on the wall surface or on the standard flush mounting box. The recommended installation height is 150...180 cm.

The device position should be selected carefully. All the error factors that can affect to the measurements should be eliminated as well as possible. The following list defines the typical measurement error factors



- direct sun light
- occupant proximity
- air flow coming from windows or doors
- air flow coming from ventilation nozzles
- air flow coming from the flush mounting box
- differential temperature caused by external wall

NOTE: CO2 measurement causes a current peak to the supply voltage. This can produce an error to the analogue outputs when using long and thin cables. It is recommended to increase the wire cross section area in long cable situations (e.g. by using four-wire connection) to ensure reliable measurement signal.

WIRING

WARNING:

Device wiring and commissioning can only be carried out by qualified professionals. Always make the wirings while the power is switched off

For wiring of external sensors (CO2, temperature, humidity), refer to the unit-specific electrical diagram (supplied in the unit cabinet).

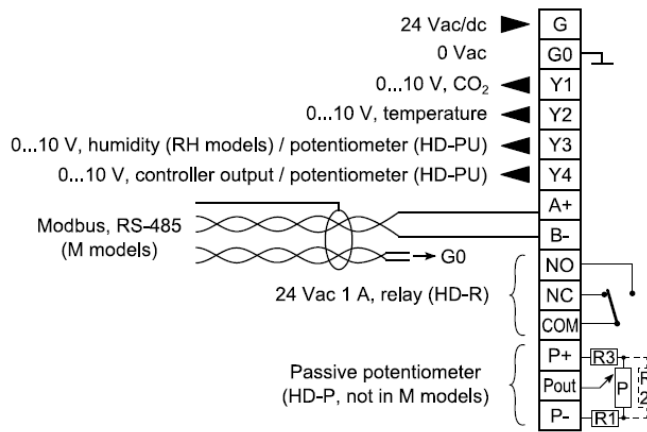

AMBIENT TEMPERATURE PROBE (MATS) (C, D, E, E+ BOX)

(SIZES 35, 45, 55, 65, 75, 85, 95, 115)

For the wiring of the external sensors (CO2, temperature, humidity), refer to the unit-specific wiring diagram (supplied in the unit cabinet).

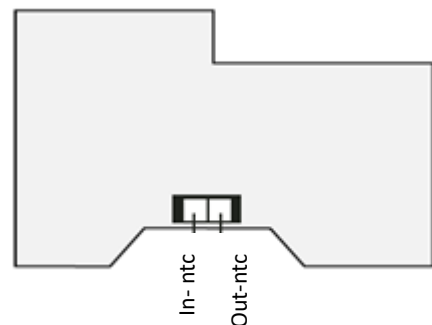

ECONOMISER AND EXTRACTION

ECONOMISER

Free cooling is provided through the use of fresh air which is more appropriate than excessive cooling amounts of return air.
 The economizer is factory fitted and tested prior to shipment.
 It includes two dampers operating from a 24V actuator



RAIN HOOD

It also includes a factory fitted rain hood. Hoods is folded during transportation to limit risks of damage and must be unfolded on site.

EXTRACTION

Installed with economizer assembly, the gravity exhaust dampers relieve the pressure when outside air is introduced into the system. When large amount of fresh air is introduced into the system power exhaust fans can be used to equalize the pressures. The extraction fan runs when return air dampers are being closed and supply air blower is in operation. The extraction fan runs when outdoor air dampers are at least 50% open (adjustable value). It is overload protected.

NOTE: When horizontal flow configuration is required, the multidirectional roof curb will be installed.

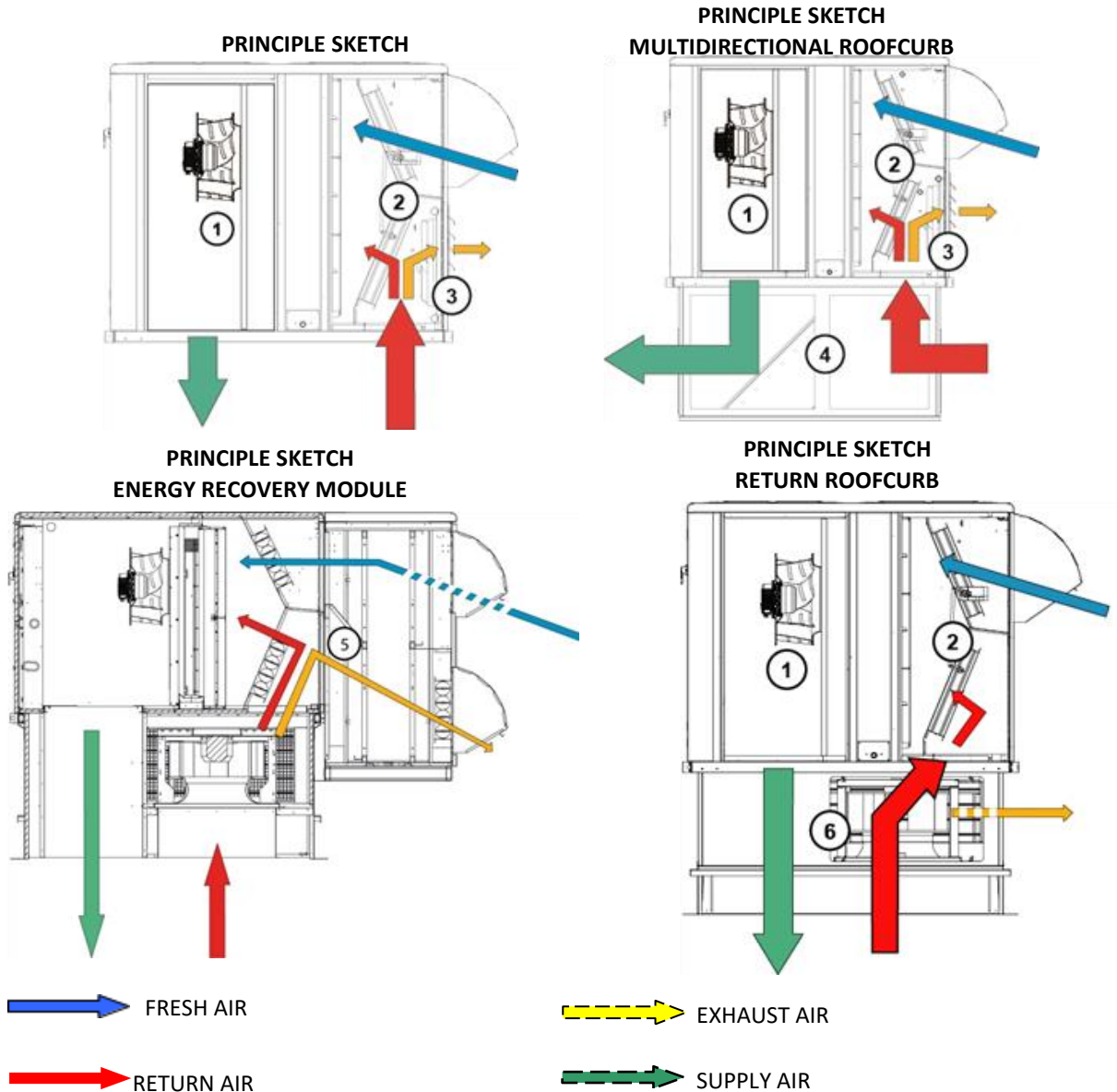

COMMISSIONING

WARNING: Check that all recommendations related to the paragraph on flammable fluids are followed before commissioning.

All the components must be installed by a qualified technician. Commissioning must only be carried out by trained refrigeration technician whom qualification certificates are compliant with the local regulation.

CASING CONDENSATION RISK

Depending of the ambient outdoor conditions and the supply air performance of the unit, some condensation on the outside skin of the unit casing may appear. This outside condensation doesn't affect the good operation of the unit, but can only affect the visual aspect of the unit.

Find below graph with condensation risk limits depending on:

- Outside Relative Humidity (% HR)
- Delta temperature (K) between Outdoor dew point temperature and Dry supply air temperature

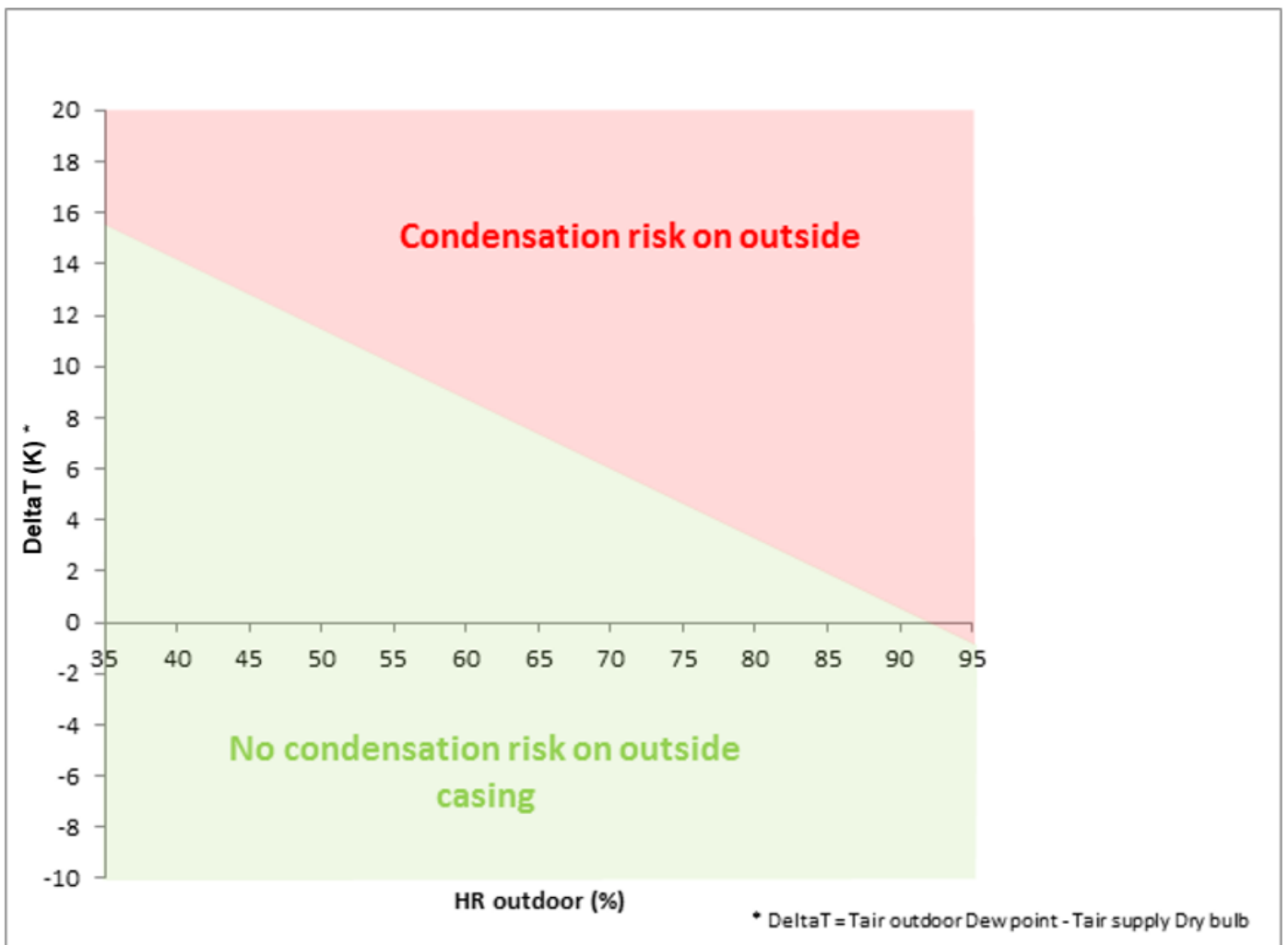

BEFORE TURNING ON THE POWER

WARNING: ensure that the power supply includes 3 phases with no neutral

Perform a leak detection with a device suitable for the refrigerant of the machine.

Ensure that the power supply between the building and the unit meets local authority standards and that the cable specification satisfies the start-up and operating conditions displayed on the rating plate.

WIRE CONNECTION TIGHTNESS CHECKS

WARNING: check the wire connection tightness before powering up the unit. Some connections may have loosen during transport

Check the following wire connections for tightness:

- Main switch connections
- Mains wires linked to the contactors and circuit breakers
- Cables in the 24V control supply circuit
- All other connections of the unit

OIL CHARGE

All units are delivered with a complete oil charge, and there is no need to add any oil before start-up or afterwards. Overcharging with oil can cause serious problems on an installation, particularly for the compressors.

The oil type depends on compressor model that depends on the unit size. Use only oil approved and recommended by Lennox

POWERING THE UNIT

Power up the unit by closing the isolator switch.

The fans and compressors direction of rotation is checked during the end of line test. They should therefore all turn in either the right or wrong direction.

WARNING: a compressor rotating in the wrong direction will fail shortly.

If one of the components rotates in the wrong direction, disconnect the power supply at the machine's isolator switch and reverse two of the component's phases on the terminal within the electrical panel.

While starting the unit, fill in the check list sheet of this manual to be sure that the unit correctly installed and ready to operate.

- Check the current values per phase on each fan motor.
- Check the current values per phase on each compressor motor.
- Check suction and discharge pressures and compressor suction temperature.
- Check chilled liquid entering and leaving temperatures if water cooled unit.
- Check outdoor air temperature and indoor temperature.
- Check if DAD is ON.
- Check that the detector has warmed up and that the LED is green.

These verifications should be made as quickly as possible with a stable cooling load, i.e. the cooling load of the installation should be the same as the capacity developed by the unit. Measurements taken without heeding this condition will result in unusable and probably wrong values.

These verifications can only be made once the proper operation of all safety devices and unit controls has been established.

Check if the customer's air ducts are open to be sure the unit is not running with ducts closed. In addition, it is needed to check if the airflow and available static pressure are in accordance with the unit.

CLIMATIC™ CONFIGURATION

SETTINGS

- 1. Supply Air-flow adjustment (depending on customer requirements)**
 - a. 3333 = nominal air flow / pressure
 - b. 3334 = reduced air flow / pressure
 - c. 3332 = Manual/Automatic
 - d. 3331 = Nominal/DeadZone/PartLoad/Pressure

- 2. Exhaust Air-flow adjustment (optional)**
 - a. 3864 = nominal air flow
 - b. 3865 = reduced air flow

- 3. Scheduling (depending on customer requirements)**
 - a. Zones & Modes (Night/Day/Day I/ DayII)
 - b. Setpoints per mode

- 4. Regulation temperature probe selection**
 - a. Select the regulation probe (DC, Return, Customer, etc.) in the Room Temp. Config screen

- 5. Regulation humidity sensor selection (optional)**
 - a. Select the regulation sensor (Remote, Customer) in the Room Hum. Config screen

- 6. Outside temperature probe selection**
 - a. Select the outdoor temp probe (Unit, Customer) in the Outside Temp. Config screen

- 7. Outside humidity sensor selection (optional)**
 - a. Select the outdoor hum sensor (Unit, Customer) in the Outside Hum. Config screen

- 8. Air quality sensor selection (optional)**
 - a. Select the air quality CO2 sensor (Remote, Customer) in the CO2 Config screen

- 9. Remote display configuration**
 - a. 3151 = DC simple / DC full / DM

- 10. Minimum fresh air**
 - a. 3121 = minimum opening %

CHECK:

1. Air-flow Vs Damper

- a. Test B.Nom100% :
 - i. adjust the blower speed % (3333) to get the required airflow
 - ii. adjust the exhaust speed % (3864) to get the required airflow
- b. Test B.Nom0%:
 - i. adjust the damper compensation (3335) to maintain the required airflow even with damper fully closed
 - ii. adjust the damper compensation (3366) to maintain the required airflow even with damper fully closed

2. Filter safety thresholds

- a. Test B.Nom100% and Test B.Nom0% : read filter ΔP (3442) and adjust the bigger measure multiplied by 2.5 at threshold 3345

3. Frigorific circuit tests

- a. Cooling mode
 - i. Test C---Cool: (if variable speed compressor option, set speed value)
 - 1. Check circuit pressures and temperatures
 - 2. Check electrical consumptions
- b. Heating mode
 - i. Test C---Heat: (if variable speed compressor option, set speed value)
 - 1. Check circuit pressures and temperatures
 - 2. Check electrical consumptions

4. Unit option tests

- a. Electrical Auxiliary heaters (Test H1-1 Full)
 - i. Check supply temperature
 - ii. Check electrical consumption
- b. Hot Water Auxiliary heaters (Test H1-1 Full)
 - i. Check supply temperature ii. Check valve opening
- c. Gas burner heaters (Test H1-1 Full)
 - i. Refer to gas burner chapter
- d. Electrical Fresh-air pre-heaters (Test H2-1 Full)
 - i. Check supply temperature
 - ii. Check electrical consumption
- e. Hot water eRecovery heaters (Test H2-1 Full)
 - i. Check supply temperature ii. Check valve opening
- f. TRMO
 - i. Test C3---Cool:
 - 1. Check circuit pressures and temperatures
 - 2. Check electrical consumptions
 - ii. Test C3---Heat:
 - 1. Check circuit pressures and temperatures
 - 2. Check electrical consumptions
- g. HRMO (Rotary Wheel)
 - i. Check wheel motor rotation

WARNING! During the settings, wait until the economizer is fully closed or opened, since it takes 1-2 minutes to switch.

5. Advanced regulation optimization

- a. Compressor ΔT
 - i. Cooling.
 - 1. Test C1c1 Cool: read |Mix-Supply| temp and adjust compressor stage ΔT at menu 3434
 - ii. Heating.
 - 1. Test C1c1 Heat: read |Mix-Supply| temp and adjust compressor stage ΔT at menu 3444
- b. Auxiliary Heaters ΔT (Gas burner or electrical)
 - i. Heating.
 - 1. Test H1-1: read |Mix-Supply| temp and adjust heaters stage ΔT at menu 3734
- c. Staging sequence (compressor/electrical/water/burners)
 - i. Aux Heaters Priority 3731= Never/ Always /OutTemp
 - ii. Pre Heaters Priority 3736= First/Last
- d. Dynamic setpoint
 - i. 3225= ΔT between customer set point and outdoor temperature
- e. Fine temperature control
 - i. Smooth 3231= No/ DeadZone/Comfort

Once all the settings have been adjusted, the list of parameters must be downloaded (Wizard tool), stored and signed by the customer.

FRESH AIR WOOD

INSTALLING

The fresh air hood has to be opened and secured during commissioning.

The 3 parts of the fresh air hood have to be assembled thanks to self-taping screws delivered in the spare part box. Check the proper position of the black seal on the top of the hood cover.

Install the remote fume hoods in a safe place without risk of aspiration of dust, grease, gas and hazardous materials.

WIND DIRECTION

The prevailing wind has to be considered while choosing the machine position on the building roof.

It's highly recommended to avoid putting the fresh air hood in the prevailing wind direction to avoid water ingress risks. If this is not possible please contact us to require specific water droplet strainer in the hood section.

WARNING: the fresh air hood cover can hurt your head if you don't pay attention while turning around the unit.

FILTERS

FILTER REPLACEMENT

After opening the filter access panel, lift the filter retaining log.

The filters can then be removed and replaced easily by sliding the dirty filters out and clean ones in.

The CLIMATIC controller monitors the pressure drop across the filter.



The following set points can be adjusted depending on the installation.

- “Airflow” in menu 2333 = 25 Pa by default
- “No filter “ in menu 2334 = 50 Pa by default
- “Dirty Filter” in menu 2335 = 250 Pa by default

The actual pressure drop measured across the coil can be read on the Climatic Display DS in menu 2332.

The following faults may be identified

- Fault code (1) Blower, Flow Switch Cut Off, if measured ΔP across the filter and coil is below the value set in menu 2333
- Fault code (4) Blower, Filters, Dirty if measured ΔP across the filter and coil is above the value set in menu 2335
- Fault code (5) Blower, Filters, Missing, if measured ΔP across the filter and coil is below the value set in menu 2334

BE CAREFUL:

Choose the filters' fire classifications according to the local regulations

BE CAREFUL:

Please perform a leak detection.

Please note that filters can generate static electricity and are potentially flammable.

REFRIGERANT CIRCUIT

GENERIC REFRIGERANT SKETCH

Depending on the unit size or the selected options, the number of circuits and compressors can change. The specific principle diagram is at the end of the electrical diagram supplied with the unit. Some connection valves (Schrader type) are available to load/unload the circuit.

C BOX (SIZES 35, 45):

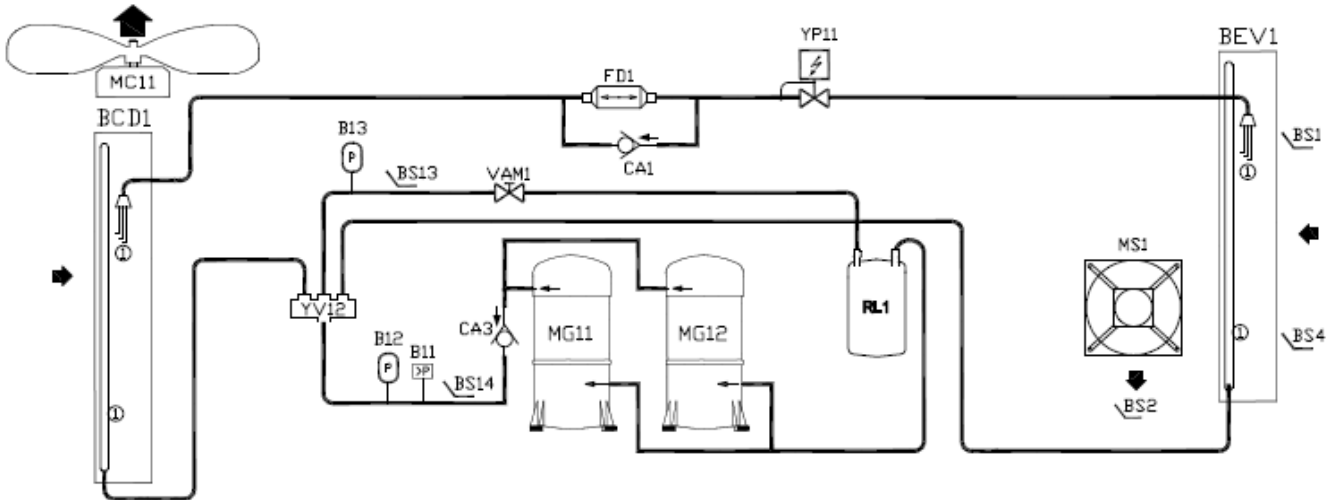

D, E BOX (SIZES 55, 65, 75, 85) :

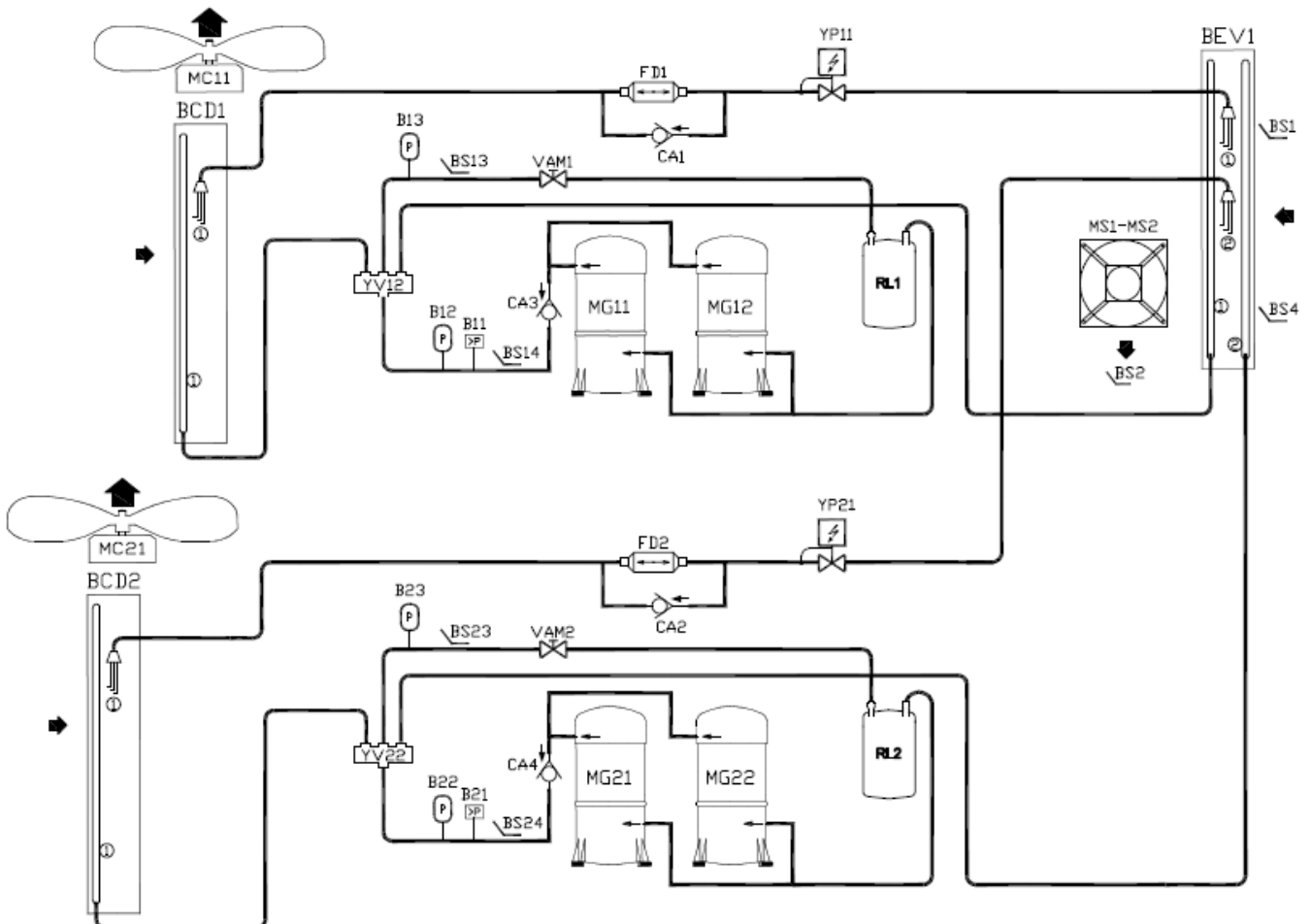

BEV-	Indoor coil
BS-	Temperature sensor
YP-	Expansion valve
CA-	Check valve
FD-	Filter dryer
BCD-	Outdoor coil
B-	Low/High pressure switch
YV-	Cycle reversal valve
MG-	Compressor
VAM-	Manual valve
RL-	Suction line accumulator

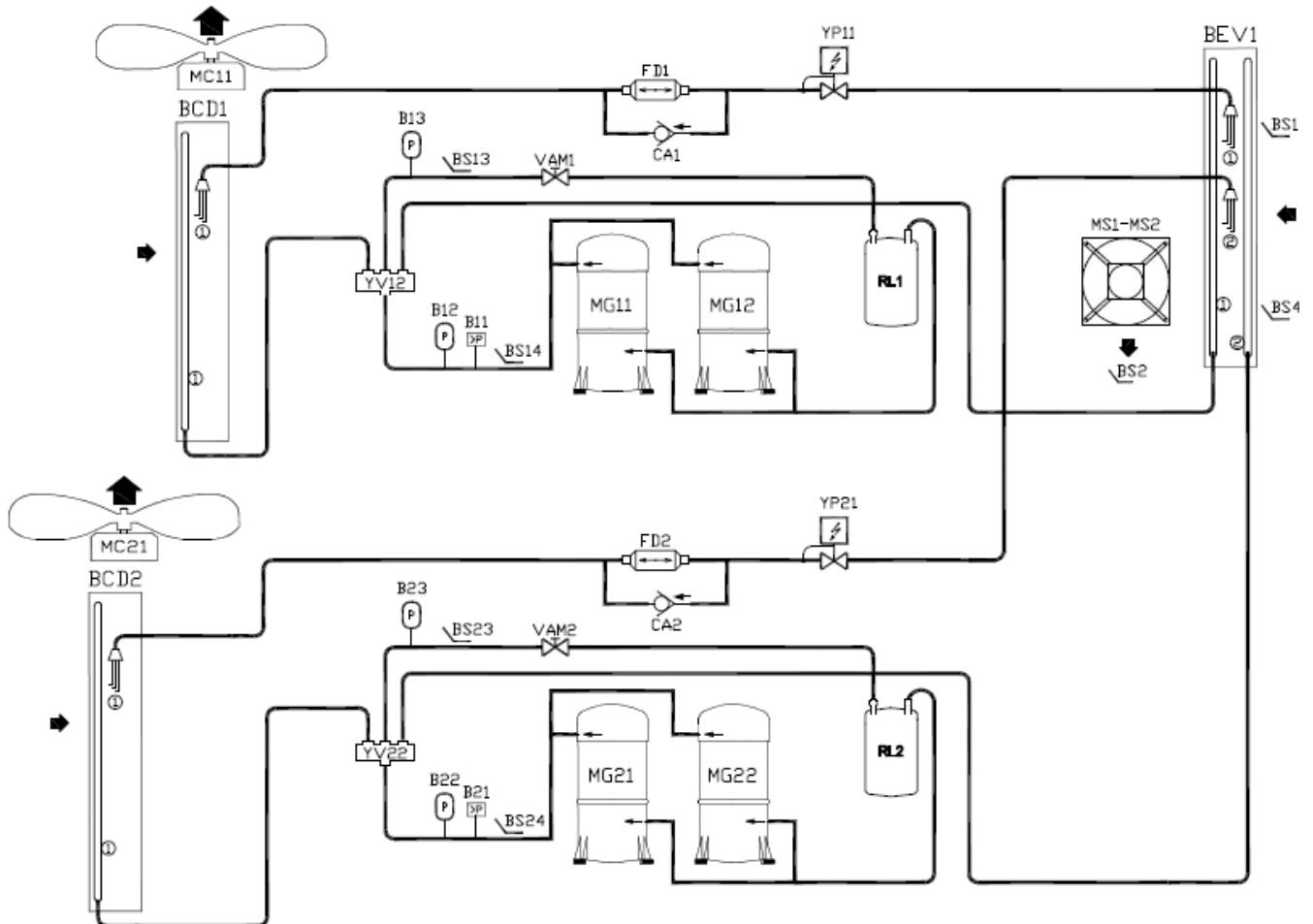
E+, F BOX (SIZES 95, 115, 100, 120):

BEV-	Indoor coil
BS-	Temperature sensor
YP-	Expansion valve
CA-	Check valve
FD-	Filter dryer
BCD-	Outdoor coil
B-	Low/High pressure switch
YV-	Cycle reversal valve
MG-	Compressor
VAM-	Manual valve
RL-	Suction line accumulator

G BOX(SIZES 130,150)

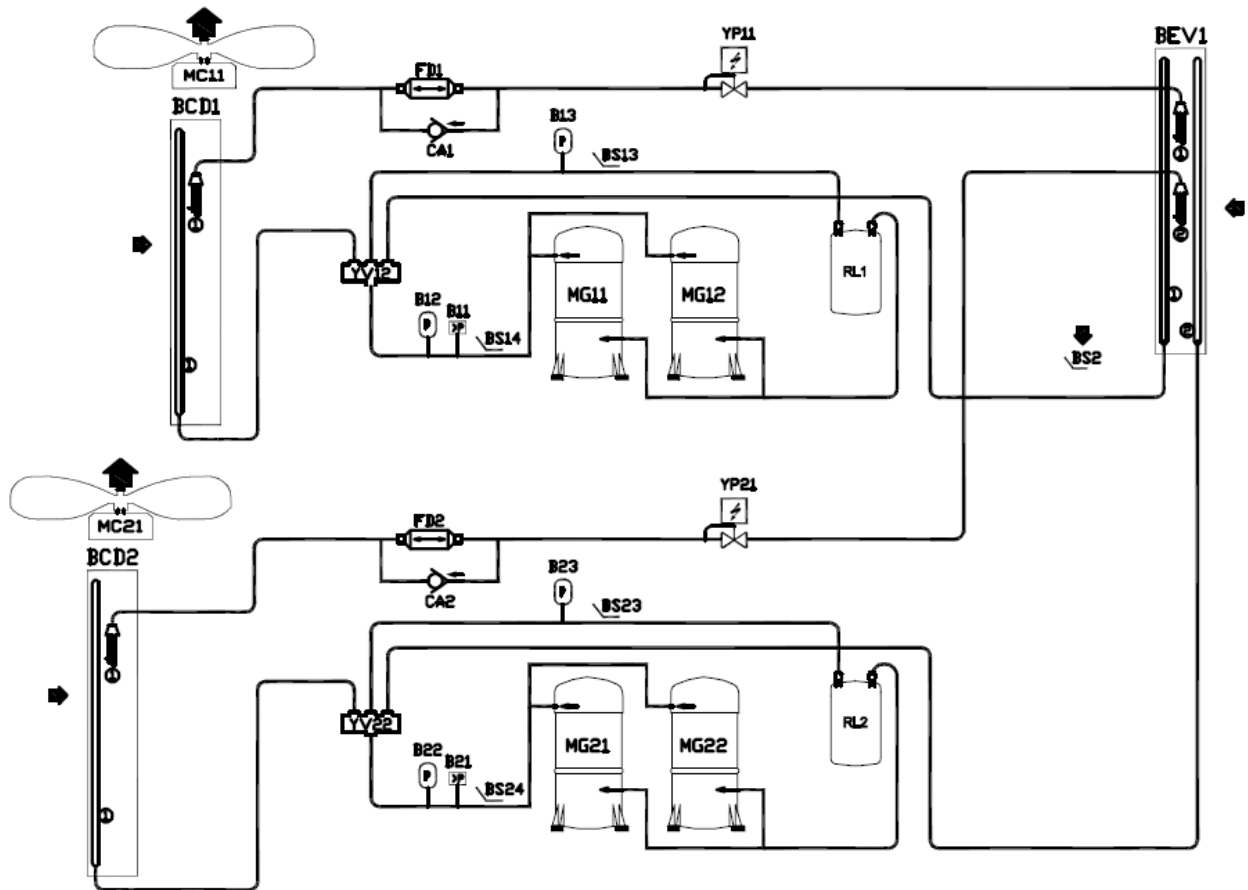

BEV-	Indoor coil
BS-	Temperature sensor
YP-	Expansion valve
CA-	Check valve
FD-	Filter dryer
BCD-	Outdoor coil
B-	Low/High pressure switch
YV-	Cycle reversal valve
MG-	Compressor
RL-	Suction line accumulator

H BOX (SIZES 180, 210)

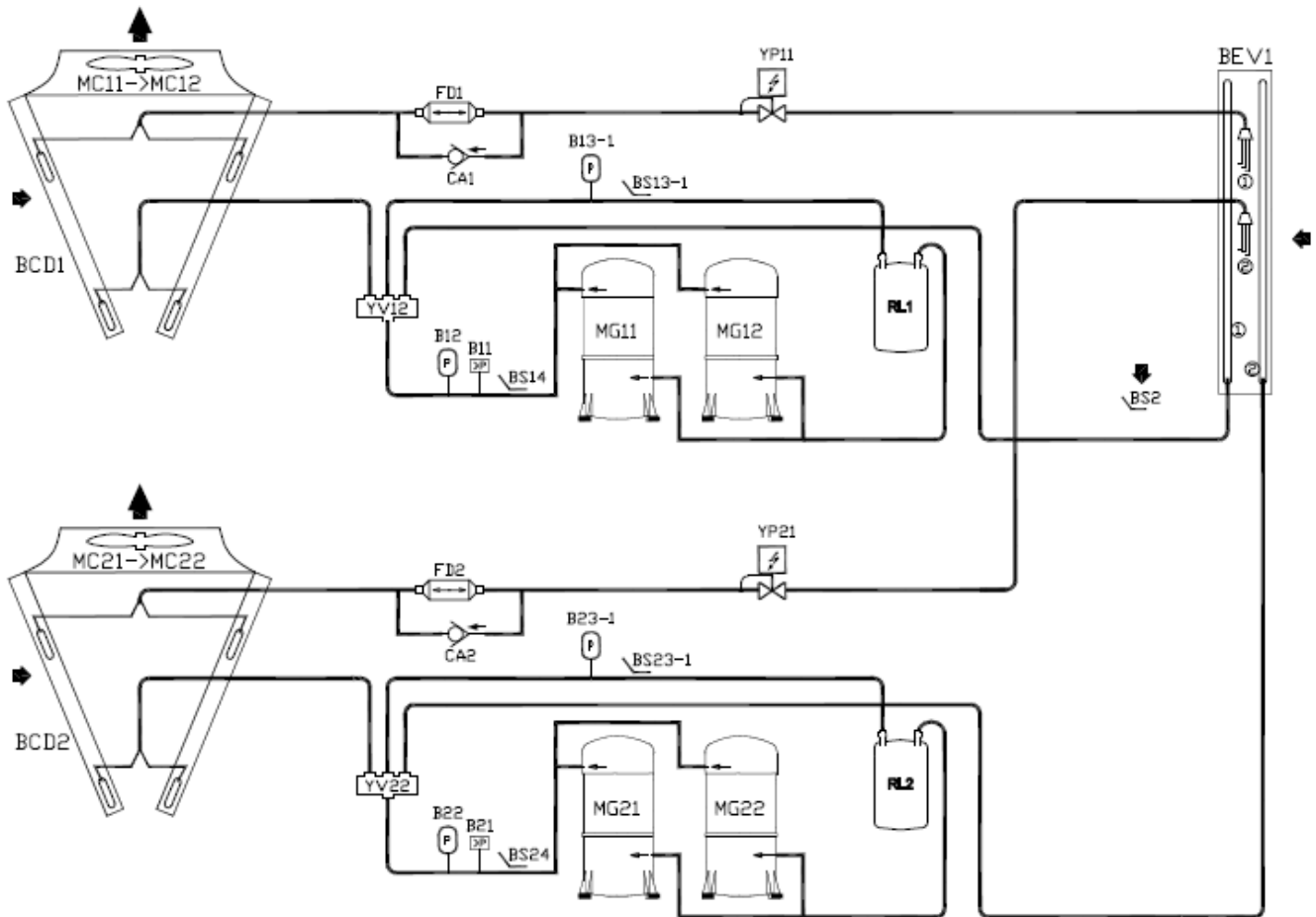

BEV-	Indoor coil
BS-	Temperature sensor
YP-	Expansion valve
CA-	Check valve
FD-	Filter dryer
BCD-	Outdoor coil
B-	Low/High pressure switch
YV-	Cycle reversal valve
MG-	Compressor
RL-	Suction line accumulator

PREHEATING OF THE CRANKCASE HEATERS

It's important to avoid starting the compressors without preheating of the crankcase heaters. The crankcase heaters are regulated according to the outside temperature (< 16°C).

WARNING:

In case of extended shutdown of the unit (> 6 hours), it is mandatory to power on the unit 8 hours minimum before to start the compressors equipped with crankcase heaters

ELECTRONIC EXPANSION VALVE

Different electronic valves types can be fitted on e-Baltic range.

	C BOX	D BOX	E BOX	E+ BOX	F BOX	G BOX	H BOX
Model designation	35-45	55-65	75-85	95-115	100-120	130-150	180-210
Reference	E2V30	E2V30	E2V30	E3V45	E3V45	E3V45	E3V55

ELECTRONIC EXPANSION VALVE ADJUSTMENTS

EEV allows to control superheat in bi-flow operation (see climatic user manual).

WELDING INSTRUCTIONS

Electronic expansion valves are sensitive to dust – strainers must be used in case of replacing.

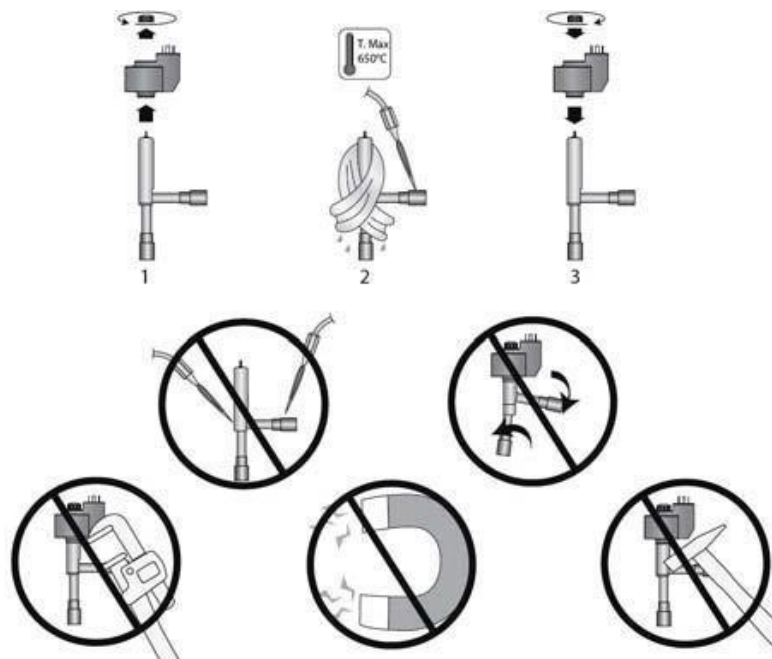

HEATING OPTION

When a heating option is installed, it is recommended to have a pressure drop of at least 100Pa in the supply duct (for example, in the case of a short supply duct, it is recommended to add a grille at the outlet of the duct).

HOT WATER COIL

HYDRAULIC CONNECTIONS

Hot water coils offer fully modulating control through the use of a 3-way valve. The hot water coil, connections and valves are all tested at pressure of 15 bars. Frost protection is provided by forcing the opening the 3-ways valve when supply temperature from hot water coil falls below 8°C and by stopping the outdoor fan when that supply temperature falls below 6°C. In addition to that, the 3-ways is also opened at 10% value if the outdoor temperature falls below an adjustable value.

Hot water coils are always factory fitted, wired and fully tested, prior to shipment.

Hot water coil includes automatic purge system.

The hot water coil is fitted with a three-ways proportional valve and two isolating shut off valves. Two spanners must be used to tighten the connections. One spanner must maintain the valve body when connecting the pipe-work to the main. Failure to do so may damage the pipes joints and invalidates the warranty.

Filling up and starting the system

- Adjust the control for Heating by reducing the simulated ambient temperature down to 10°C
- Check that the red indicators located under the valve actuator are moving correctly with the signal.
- Fill the hydraulic system and bleed the coil using the air vents. Check incoming hot water.
- Check the various connections for possible leaks



FREEZE PROTECTION

1) Glycol for freeze protection

Check the hydraulic system contains Glycol for protection against freezing

GLYCOL IS THE ONLY EFFECTIVE PROTECTION AGAINST FREEZING

The antifreeze must protect the unit and avoid icing under winter conditions.

WARNING: Mono-ethylene glycol based fluids may produce corrosive agents when mixed with air

2) Drain the installation

You must ensure that the manual or automatic air bleeders have been installed on all high points in the system. In order to drain the system, check that all the drain cocks have been installed on all low points of the system

HOT WATER COILS FROZEN DUE TO LOW AMBIENT CONDITIONS ARE NOT COVERED BY THE WARRANTY

ELECTROLYTIC CORROSION

Attention is drawn to the corrosion problems resulting from electrolytic reaction created by unbalanced earth connections

ANY COIL DAMAGED BY ELECTROLYTIC CORROSION IS NOT COVERED BY THE WARRANTY

HOT WATER COIL CONNECTION

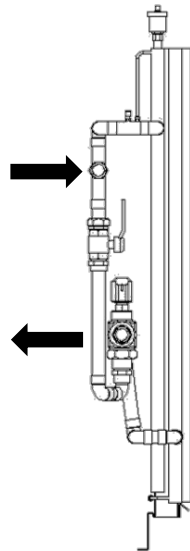

PIPE INTERNAL DIAMETERS (DN)

	C BOX	D BOX	E BOX	E+ BOX	F BOX	G BOX	H BOX
Model designation	035-045	055-065	075-085	095-150	110-120	130-150	180-210
S					25	32	32
H	40	40	40	40	32	40	40

MAXIMUM WORKING PRESSURE: 8 BARS / MAXIMUM WORKING TEMPERATURE: 110°C

ELECTRIC HEATERS

The electric heater comprises of shielded resistance heaters, which are smooth stainless steel tubes 6 W/cm² capacity.

High temperature limit control offers overload protection and is set to 93°C and located at less than 150mm after electric heaters. This is provided as a standard feature on the electric heater, with the electric power supply cables made of reticulated silicon rubber, resistant to temperatures up to 200°C.

WARNING: electric heater is connected heater to mains power – risk of electrical shock – switch off the unit prior to open this section

Size C BOX (35, 45): Standard heat: 18 kW (2 stages), High Heat (Fully modulating): 36 kW

Size D BOX (55, 65): Standard heat: 27 kW (2 stages), High Heat (Fully modulating): 54 kW

Size E BOX (75, 85): Standard heat: 27kW (2 stages), High Heat (Fully modulating): 54 kW

Size E+ BOX (95, 115): Standard heat: 27kW (2 stages), High Heat (Fully modulating): 54 kW

Size F BOX (100, 120):

Standard heat: 30 kW, 2 stages

Medium Heat: 54 kW, Fully modulating (Triac)

High Heat: 72 kW, Fully modulating (Triac)

Size G BOX (130, 150) :

Standard heat: 45 kW, 2 stages

Medium Heat: 72 kW, Fully modulating (Triac)

High Heat: 108 kW, Fully modulating (Triac)

Size H BOX (180, 210) :

Standard heat: 72 kW, 2 stages

Medium Heat: 108 kW, Fully modulating (Triac)

High Heat: 162 kW, Fully modulating (Triac)

Capacity of the medium and high heat heater can be limited electronically to an exact value through the CLIMATIC

To reduce installation time and hence cost, electric heaters are always factory fitted, fully wired and tested, prior to shipment

		380V	400V	420V
Size of the unit	Module size (kW)	Current (A)	Current (A)	Current (A)
C, D, E, E+ BOX (35,45,55,65,75,85,95,115)	18	27.3	26.0	24.7
	27	41.0	39.0	37.1
	36	54.7	52.0	49.5
	54	82.0	77.9	74.2
F, G, H BOX (100,120,130,150,180,210)	30	45.6	43.3	41.2
	45	68.4	65.0	61.9
	54	82.0	77.9	74.2
	72	109.4	103.9	99.0
	108	164.1	155.9	148.5
	162	246.1	233.8	222.7

ELECTRICAL PREHEATER (C, D, E, E+ BOX) (SIZES 35,45,55,65,75,85,95,115)

WARNING: electric pre-heater is connected heater to main power – risk of electrical Shock – switch off the unit prior to open this section

Pre-heater is running only with high fresh air rate under low outdoor ambient temperature (see setpoint in CLIMATIC™ section). A metallic filter is installed between air filter & electrical resistance to protect against heat radiations.

WARNING: electric pre-heater metallic filter must not be plugged by dust

	Amps per model size	C BOX	D BOX	E BOX	E+ BOX
		35-45	55-65	75-85	95-115
Size S/H	S 18 kW	26			
	S 24 kW		35		
	S 36 kW			52	52
	H 36 kW	52			
	H 48 kW		69		
	H 72 kW			104	104



CONDENSING GAS BURNER

PRELIMINARY CHECKS BEFORE START-UP

NOTE :

ANY WORK ON THE GAS SYSTEM MUST BE CARRIED OUT BY QUALIFIED PERSONNEL.

THIS UNIT MUST BE INSTALLED IN ACCORDANCE WITH LOCAL SAFETY CODES AND REGULATIONS AND CAN ONLY BE USED IN PLANNED INSTALLATION CONDITIONS FOR OUTDOOR.

PLEASE READ CAREFULLY THE MANUFACTURER'S INSTRUCTIONS BEFORE STARTING A UNIT.

BEFORE COMMISSIONING A UNIT WITH GAS BURNER, IT IS MANDATORY TO ENSURE THAT THE GAS DISTRIBUTION SYSTEM (TYPE OF GAS, AVAILABLE PRESSURE...) IS COMPATIBLE WITH THE ADJUSTMENT AND SETTINGS OF THE UNIT.

THE GAS MODULE SAFETY CHAIN MUST BE CHECKED BY A PROFESSIONAL BEFORE START-UP OF THE PRODUCT.

CHECK ACCESS AND CLEARANCE AROUND THE UNIT

- Make sure one can move freely around the unit.
- A minimum one-meter clearance must be left in front of the burnt gas exhaust flue.
- Combustion air inlet and burnt gas exhaust(s) must not be obstructed in any way.
- Depending on the operating conditions (prevailing winds), it may be necessary to separate the air inlets from the flue gas outlets (excluding LENNOX supply).

SUPPLY NETWORK PIPE SIZING

MALE THREADED CONNECTION FOR GAS BURNER: 3/4" ,1" OR 1"1/4

Check that the gas supply line can provide the burners with the pressure and the gas flow rate necessary to provide the heating nominal output. Select the regulator according to the gas used, the minimum and maximum gas flow of the gas burner and the operating pressure.

WARNING: DO NOT FORGET TO CONNECT THE CONDENSATE DRAIN. THE CONDENSATES MUST ABSOLUTELY BE DRAINED AT LEAST 5 METERS FROM THE UNIT INTO AN APPROPRIATE PLACE. THE CONDENSATES ARE CORROSIVE AND COULD DAMAGE THE UNIT (OR OTHER PARTS OF THE INSTALLATION) IF THEY ARE NOT DRAINED PROPERLY.

CHIMNEY INSTALLATION

Depending site configuration / local regulation, an additional chimney could be install (not included with the unit). Please refer to our Service & parts team.

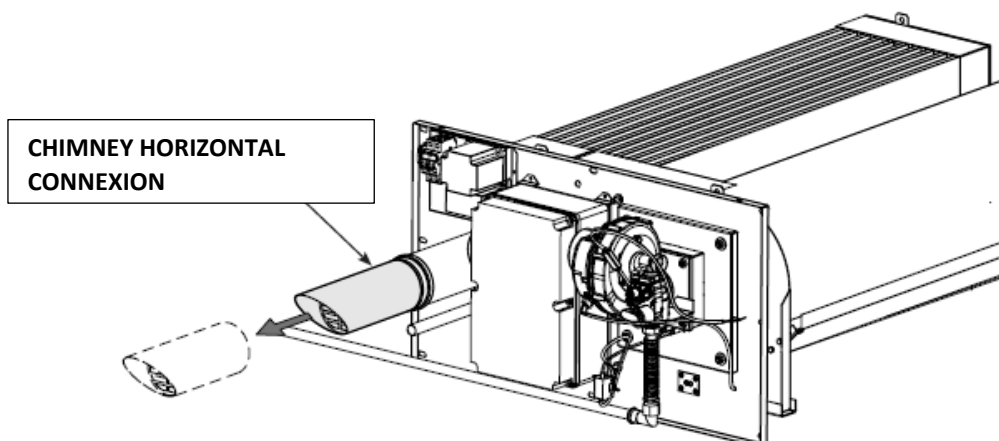

WARNING:

IT IS MANDATORY TO SEAL PROPERLY ALL EXTERNAL CONNECTIONS TO THE UNIT TO AVOID WATER INGRESS

SAFETY INSTRUCTIONS

The gas burner can emit toxic gases (Nox, CO₂, ...) especially during commissioning and when starting and stopping the burner. When the unit is in operation, the technician must work away from the gas outlet chimney. A temporary work chimney to move the fumes away from the working area (see photo) must be installed during prolonged exposures near the burner.



GAS:

Before starting up the heater, make sure that:

- The gas mains supply data is compatible with the data stated on the nameplate;
- The combustion air intake ducts (when fitted) and the fume exhaust pipes are those specified by the manufacturer;
- The combustion air is supplied in such a way to avoid even partial obstructions of the intake grille (caused by leaves etc.);
- The fuel intake internal and external seal is checked during the testing stage, as required by applicable standards;
- The heater is supplied with the same type of gas than that selected at purchase;
- The system is correctly sized for such flow rate and is fitted with all safety and monitoring devices required by applicable standards;
- The inside of the gas pipes and air distribution ducts for ducted heaters has been thoroughly cleaned;
- The fuel flow rate is suitable for the power required by the heater;
- The fuel supply pressure is between the range specified on the nameplate.

GAS LEAKS

If you smell gas:

- Do not operate electrical switches, telephones or any other object or device that could produce sparks;
- Immediately open doors and windows to create an air flow to vent the gas out of the room;
- Close the gas valves;
- Call for qualified staff.

PRODUCT RANGE

DESCRIPTION		C	C	D	D	E	E	E+	E+	F	F	G	G	H	H	
SIZE		35	45	55	65	75	85	95	115	100	120	130	150	180	210	
MAXIMAL HEAT INPUT	kW	50 45*	50 45*	70 65*	70 65*	90	90	110	110	130	130	170	170	230	230	
MINIMAL HEAT INPUT	kW	10	10	14	14	18	18	22	22	26	26	34	34	46	46	
EFFICIENCY AT MAXIMAL HEAT INPUT	%	96	96	96	96	96	96	96	96	96	96	96	96	97	97	
EFFICIENCY AT MINIMAL HEAT INPUT	%	109	109	109	109	109	109	109	109	109	109	109	109	109	109	
Max / min gas consumption at 15°C and 1013 mbar	G20	m ³ /h	1.1 5.3	1.1 5.3	1.5 7.4	1.5 7.4	1.9 9.5	1.9 9.5	2.3 11.6	2.3 11.6	2.8 13.8	2.8 13.8	3.6 18.0	3.6 18.0	4.9 24.3	4.9 24.3
	G25	m ³ /h	1.2 6.2	1.2 6.2	1.7 8.6	1.7 8.6	2.2 11.1	2.2 11.1	2.7 13.5	2.7 13.5	3.2 16.0	3.2 16.0	4.2 20.9	4.2 20.9	5.7 28.3	5.7 28.3
	G30	kg/h	0.8 3.9	0.8 3.9	1.1 5.5	1.1 5.5	1.4 7.1	1.4 7.1	1.7 8.7	1.7 8.7	2.1 10.3	2.1 10.3	2.7 13.4	2.7 13.4	3.6 18.1	3.6 18.1
	G31	kg/h	0.8 3.9	0.8 3.9	1.1 5.4	1.1 5.4	1.4 7.0	1.4 7.0	1.7 8.6	1.7 8.6	2.1 10.1	2.1 10.1	2.6 13.2	2.6 13.2	3.6 17.9	3.6 17.9
Supply pressure +/- 5%	G25	mbar	20	20	20	20	20	20	20	20	20	20	20	20	20	20
	G30	mbar	25	25	25	25	25	25	25	25	25	25	25	25	25	25
	G20	mbar	37	37	37	37	37	37	37	37	37	37	37	37	37	37
	G31	mbar	37	37	37	37	37	37	37	37	37	37	37	37	37	37
Gas inlet connection	inch	3/4"	3/4"	3/4"	3/4"	3/4"	3/4"	3/4"	3/4"	1"	1"	1"1/4	1"1/4	1"1/4	1"1/4	
Chimney outlet diameter	mm	100	100	100	100	100	100	100	100	130	130	130	130	150	150	
Max length of gas exhaust pipe	m	5	5	5	5	5	5	5	5	5	5	5	5	5	5	
Nominal electrical power	W	65	65	135	135	173	173	170	170	180	180	250	250	250	250	
Operation temperature (incoming air)	°C	-20 / 40														
Gas volume between regulator and gas burner	m ³	0.02	0.02	0.031	0.031	0.039	0.039	0.048	0.048	0.056	0.056	0.065	0.065	0.095	0.095	

(*) For gases : G25 / G27 / G2.350

GAS BURNER DETAILS

- Premix burner (venturi, gas fan, pilot group, head) gas valve
- Electronic controls with display
- Combustion chamber in stainless steel AISI 441
- Exchanger bundle in stainless steel AISI 441
- Safety probe
- The PREMIX Technology: NO AIR=NO GAS

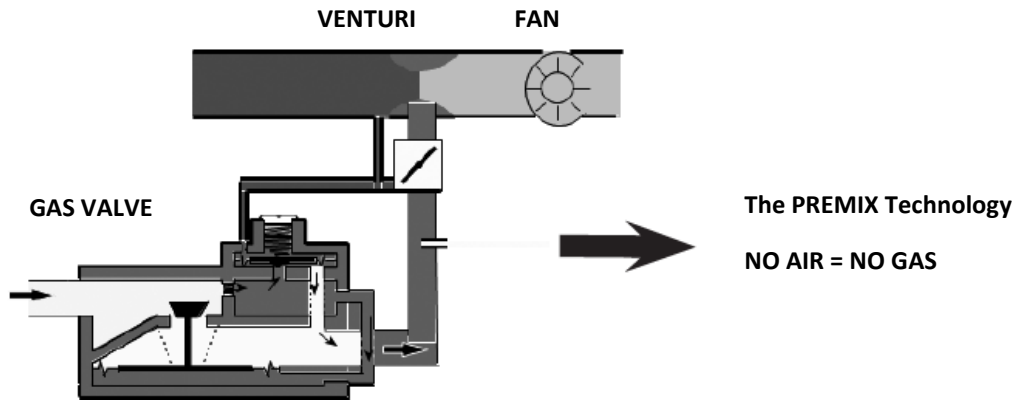

WORKING CYCLE

- Heat is required
- Burner fan starts to pre-wash combustion chamber and gas valves open to gas feed pilot burner
- Start up electrode gives ignition sparks on pilot burner
- Main gas valve opens to gas feed main burner
- Combustion starts thanks to pilot flame ignition
- The electronic boards close and stops the pilot

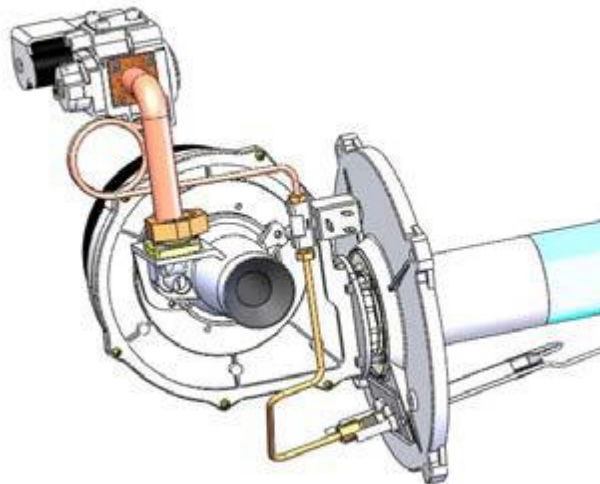

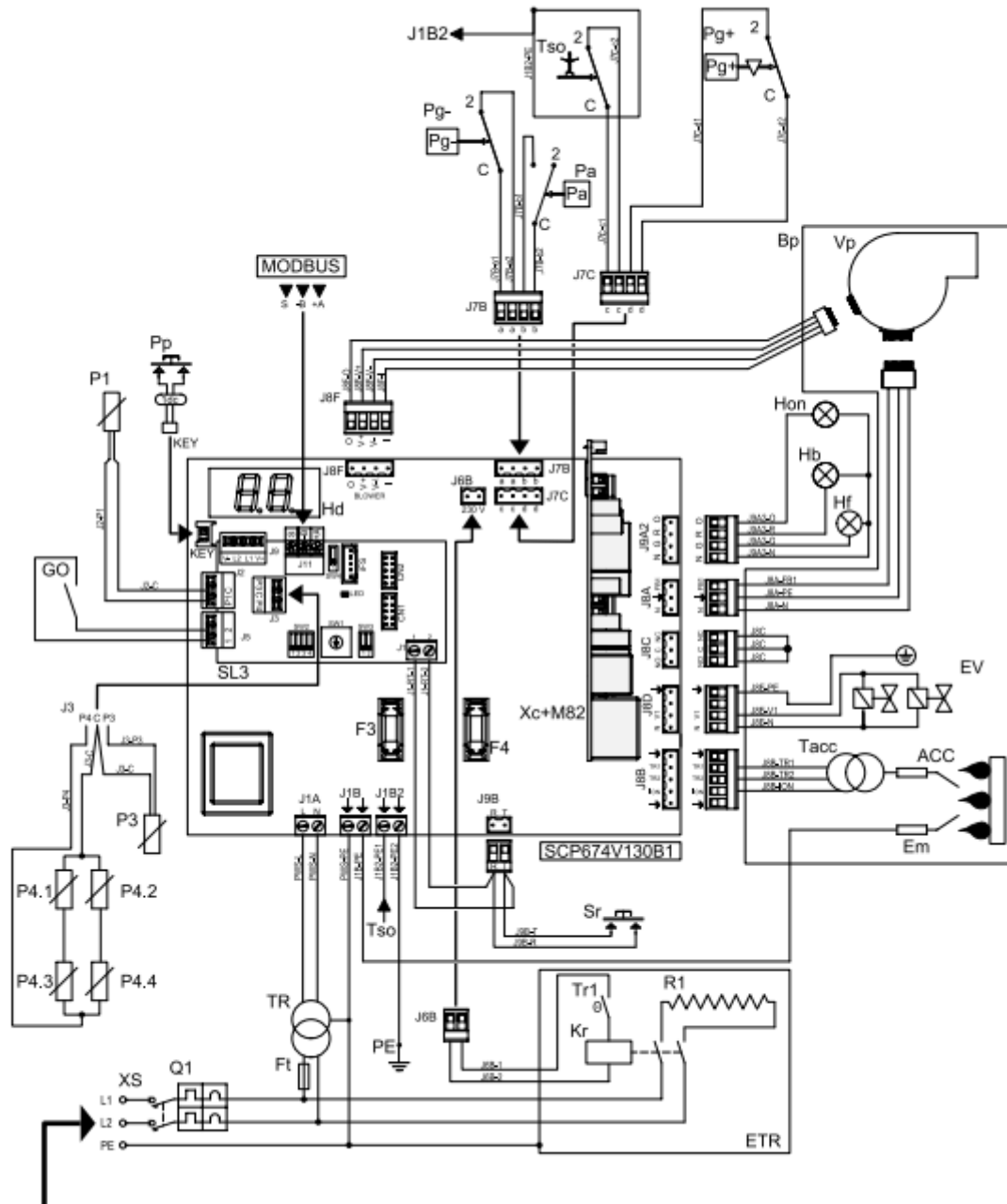
ELECTRICAL CONNECTION**WARNING**

It is mandatory to have earth connection.

GAS CONNECTION

The module cannot support supply pressures higher than 50 mbar (0.05 bar) otherwise it can break of the gas valve membranes.

For natural gas: always install a stabilizer on the main line.

For gas GPL (Butane-Propane) gas: a pressure reducer must be installed

It is strictly forbidden to supply gas to the circuit at a pressure higher than 40 mbar. To avoid a pressure higher than 40 mbar, a minimum volume must be present between the regulator (pressure reducer) and the inlet of the gas burner, you can find these minimum values in the table "PRODUCT RANGE". For this purpose, either a buffer cylinder must be installed (not included in our kit).

Either a straight length of at least 10 m, and no pressure stabilizer should be placed between the pressure reducer and the burner. The gas filter must be present and functional . In order to respect the minimum and maximum flow rates of the regulators, it is recommended to install only one regulator per unit.

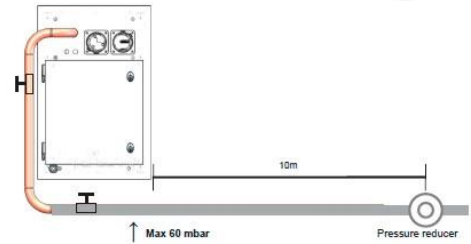

A pressure gauge must always be installed upstream and downstream of the main gas supply line visible with a scale of [0 – 60] mbar (0.06 bar) in order to verify any difference in upstream and downstream pressure and therefore the flow rate of the entire network.

It is also possible, by closing the general valve and turning off the module, to check the tightness of the system and gas valves, checking, after a short period, for any pressure drop on the pressure gauges.

Always connect the module with a ball valve and anti-vibration flexible gas joint.

Gas supply pressure adjustment: all modules are tested and calibrated in the factory for the pressures for which they are designed.

Do not block the electrical cabinet with the gas connection (use a flexible pipe or rigid with elbows)

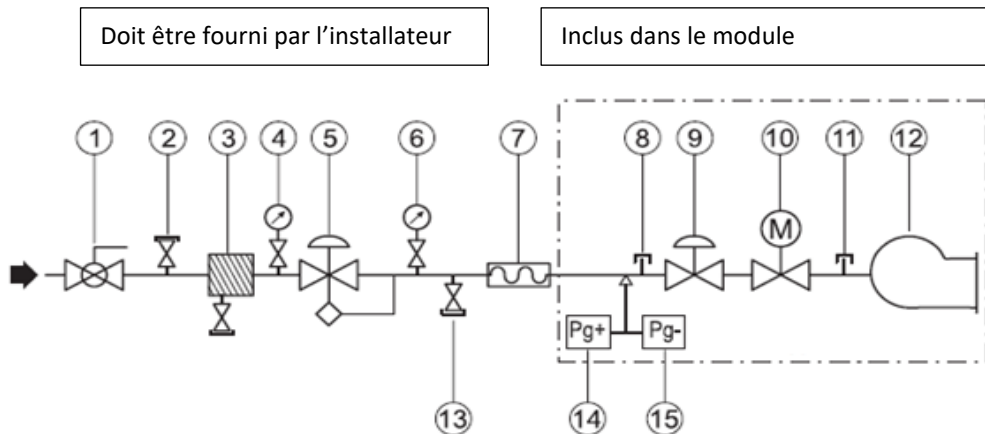

Doit être fourni par l'installateur

Inclus dans le module

POS.	DESCRIPTION		
1	Manual gas shut-off ball valve	9	Gas pressure regulator located on the appliance solenoid valve
2 -8-11	Gas pressure intake	10	Safety solenoid valve
3	Gas filter	12	Burner
4 -6	Pressure gauge	13	Ball valve with bleed
5	Gas pressure regulator with minimum and maximum pressure blocking device (outlet pressure = 0.04 bar) - For inlet pressures < 0.04 bar provide a stabilizer	14	Maximum gas pressure switch with manual reset - optional
7	Antivibration seal	15	Minimum gas pressure switch - optional

CONDENSATE DRAIN

WARNING: Do not forget to connect the condensate drain (No need to add a siphon). The condensates must absolutely be drained at least 5 meters from the unit into an appropriate place. The condensates are corrosive and could damage the unit (or other parts of the installation) if they are not drained properly.

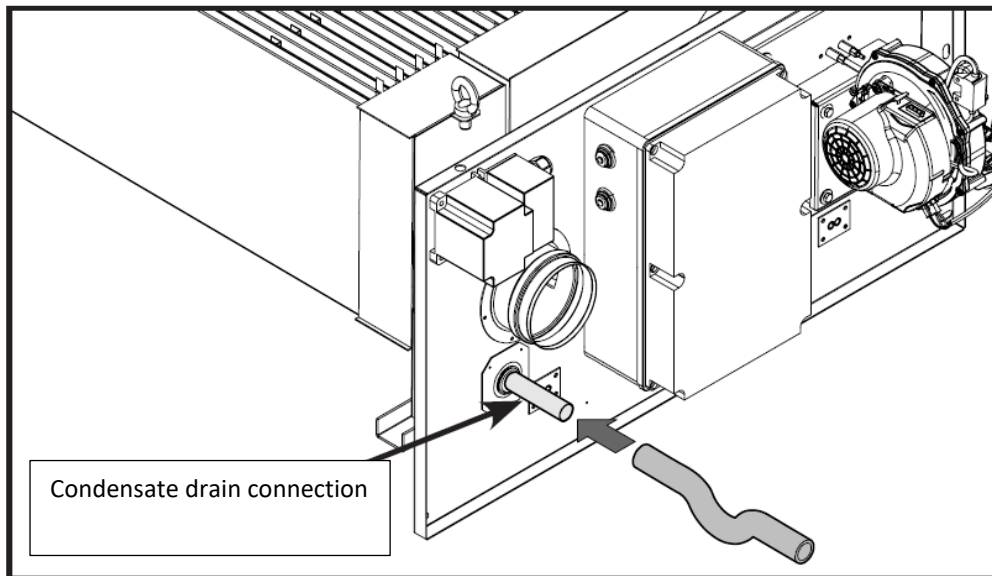

COMMISSIONING

The gas module unit is supplied with settings entered and tested for the gas specified on the nameplate. Before turning on the gas module in the unit, check the following:

- Vent the gas supply line and carefully let the remaining air out of the pipes.
- Restore the gas supply piping after venting and check that there are no leaks, use a soapy solution or equivalent product, do not use open flames.
- Check that electrical connections indicated in electrical diagrams attached to the unit
- Check that efficient earthing connections have been completed, carried out as specified by current safety regulations;
- Provide power to the heater with the general switch on the unit.
- After the pre-wash time, the ignition spark occurs. After the third failed ignition attempt, the device locks up. After 10 seconds, it is possible to unlock the device by resetting the burner control equipment.
- After opening the gas solenoid valve, the burner ignites.
- After the stabilization of the working conditions (about 15 min.), Carry out a combustion analysis and a performance measurement.
- Recheck the combustion verification check sequence after 30 minutes of operation.
- Adjust Y2

Combustion control and regulation:

- Put the burner in test mode
 - Start the gas burner with the H1-FULL test mode (with the DS)
 - Hold the SET button until "PA" is displayed
 - Enter the authorization code.
 - Hold the SET button until "yt" is displayed
 - Press the button, change the value «e.g. „15" » , for 15 minutes the burner will work in test mode. After this time, the control returns to automatic mode. Use this time to perform the combustion check.

- Verification of combustion: Procedure for changing the power of the gas burner (low / high power)
 - Hold the SET button until "yC" is displayed
 - Press the button to change the value
 - Put «„61"» - for high power
 - Put «„51"» - for low power
 - For the above conditions, check the exhaust gases
 - Check the regulation (behavior) of the burner .



Adjustment of Lo/Hi power with the combustion analyzer.

First in max capacity:

- Set-up λ (screwing Lo/ Hi as explained below in the picture) around **1.35** (it is a target) to get :
 - $7.8\% \leq \text{CO}_2 \leq 8.9\%$ (for G20 only)
 - $\text{CO} \approx 0$ ppm
 - But if you have combustion problems (noise (whistle), turbulences, High CO), you can adjust the λ (air factor) from 1.2 to 1.65 to solve these problems.
 - $\eta > 90\%$
 - $\text{NOx} < 30\text{ppm}$

Then in min capacity:

- Set-up λ (screwing Lo/ Hi as explained below in the picture) around **1.40** (it is a target) to get:
 - $7.8\% \leq \text{CO}_2 \leq 8.9\%$ (for G20 only)
 - $\text{CO} \approx 0$ ppm
 - But if you have combustion problems (noise (whistle), turbulences, High CO), you can adjust the λ from 1.2 to 1.65 to solve these problems.
 - $\eta > 102\%$
 - $\text{NOx} < 30\text{ppm}$

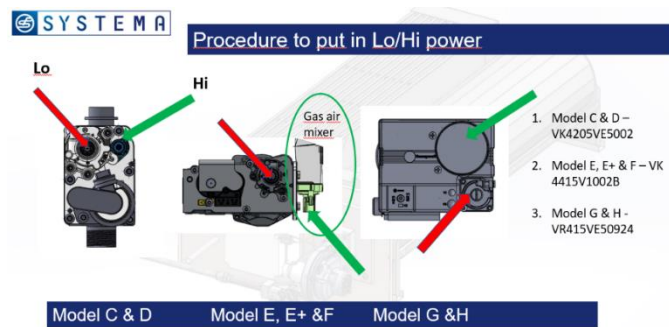

Y2 adjustment

Parameter Y2 adjusts the power of the gas burner at start-up. This adjustment is made after the Lo/Hi power and gas supply pressure adjustments have been set. The Y2 parameter should be between 18 and 25%, by default 20%.

If there is a small explosion at start-up: decrease Y2

If the flame is slow to ignite due to turbulence: increase Y2

Y2 change procedure:

- Hold the SET button until "PA" is displayed.
- Enter the authorization code.
- Hold the SET button until "Y2" is displayed.
- Press the button and set the desired value.



MAINTENANCE OPERATIONS

To keep the machine in efficient condition and guarantee a long lifetime of the heater, it is advisable to run some inspections every year:

NOTE: Operations at points 1 to 7 must be performed after disconnecting the heater from the electrical mains and closed the gas intake. Operations at point 8 to 12 must be done with the heater on.

1) Inspection of electrodes

Dismantle the complete pilot flame and use a jet of compressed air to clean the mesh and nozzle. Check the integrity of the ceramic and use sandpaper to remove any oxidation on the metal parts of the electrodes. Check the correct position of the electrodes (see drawing below). It is important that the detection electrode is at a tangent to the head of the pilot and not inside it. The start-up electrode must discharge onto the mesh of the pilot burner.

2) Inspection of fume exhaust and air intake ducts

Visually inspect where possible or examine with specific tools to learn the status of the ducts.

Remove dust that forms on the air intake terminal.

3) Inspection and cleaning of the venturi

Remove any dirt at the mouth of the venturi with a brush, and be careful to not let it fall inside the piece.

4) Inspection and cleaning of the exchanger and burner

Perfect combustion in heaters prevents dirt. It is advisable, therefore, to not clean the exchanger and burner unless there are exceptional circumstances.

An accumulation of dirt inside the exchanger could be revealed by a sizeable variation in the module gas capacity.

Should it become necessary to clean the burner and/or exchanger, all of the gaskets mounted between the burner and the exchanger must be replaced.

5) Inspection and cleaning of the water trap

Clean the trap every year, and check the connections. Make sure there are no traces of metallic residue. If metallic residue has formed, increase the number of inspections.

6) Inspection of the gas filter

Remove the dirt on the gas filter. If it is too dirty, replace it.

7) Inspection of the ionization current

With the gas burner at rest, use a multimeter, check that the current displays 20 to 30 mA at the probe terminals.

8) Inspection of intake gas pressure

Verify that the intake pressure at the valve corresponds to the value required for the type of gas that you are using. This verification must be done with the heater on at the maximum heat capacity.

If the gas pressure is too high at the gas inlet valve, there is a risk of ejection of the chimney. In this case, check that the gas inlet pressure regulator (if present) is working correctly

9) Check the burner settings

Adjust with a combustion analyzer the values described in the paragraph: " Adjustment of Lo/Hi power with the combustion analyzer."

10) Inspection of flame monitoring equipment

With the heater operating, close the gas tap and verify that the heater blocks, signaled on the LCD display. Reopen the gas tap, reset the block and wait for the heater to start back up.

11) Safety thermostat inspection

Disconnect the safety thermostat and check that the alarm is working properly. Inspect the thermostat head.

RECOVERY WATER COIL C,D,E,E+ BOX (35,45,55,65,75,85,95,115)

Heat recovery water coil is delivered with a 3 ways valve inside carton to be assembled on site by installer.



The freeze protection is made via fresh damper safeties nevertheless for a full freezing protection has to be done using glycoled water

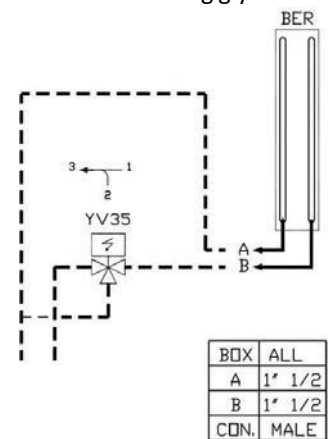

MAINTENANCE DIAGNOSTIC

REFRIGERATION		
FAULT	POSSIBLE CAUSE AND SYMPTOMS	SOLUTION
LP FAULT	Refrigerant charge too low	Measure the superheat and sub-cooling Good if $5^{\circ}\text{C} < \text{SC} < 10^{\circ}\text{C}$ and $5^{\circ}\text{C} < \text{SH} < 10^{\circ}\text{C}$ Bad if $\text{SC} > 10^{\circ}\text{C}$ and SH too low Check superheat adjustment and charge unit (a leak check must be carried out)
	In Heat Pump Mode the temperature difference between T outdoor and T _{evap} . (Dew) is too high $5^{\circ}\text{C} < \Delta T < 10^{\circ}\text{C}$ excellent $10^{\circ}\text{C} < \Delta T < 15^{\circ}\text{C}$ acceptable $15^{\circ}\text{C} < \Delta T < 25^{\circ}\text{C}$ too high	If too high check the coils are clean or check coil internal pressure drop between the liquid line and the suction line Good if $< 3\text{bar}$ Too high $> 3\text{bar}$ (coil blocked)
	Refrigeration circuit blocked in distribution	Stop the fan and create icing of the coil. Check all circuits freeze evenly across the whole surface of the coil If some parts of the coil do not freeze this could indicate a problem with the distribution
	Liquid line drier blocked. High temperature difference	Change filter drier
	Electronic expansion valve problem	Check the wiring
	Low pressure shutdown due to ice accumulation on the batteries	Check the defrost cycles. (cloud supervision advised)

REFRIGERATION		
FAULT	POSSIBLE CAUSE AND SYMPTOMS	SOLUTION
HP FAULT	Incorrect airflow rates	Heat pump mode: Check the filter before the indoor coil measure and estimate the airflow rate increase the speed of the fan Cooling mode: Check the condenser fan
	Moisture or contaminants in the system	Summer operation Several hours after the unit has stopped, check for the presence of non-condensable substances
	Moisture or contaminants in the system Condenser coil is obstructed	If the circuit pressure is higher (<1bar) than the saturated pressure corresponding to the measured outdoor temperature, there is possibility that some contaminants are present in the system. Reclaim the refrigerant, and vacuum the circuit (For flammable refrigerant, please follow the procedure described in the manual) Recharge the unit
	Recycled Hot Air	Check the condenser coil and clean is necessary Check clearance around the condenser
Strong variations of pressure (2 to 3 bars). Expansion valve "hunting"	Incorrect adjustment of the expansion valve	Refer to the LP FAULT section
	Low refrigerant charge	Repair the leak and fill with liquid
	The pressure regulator is not sufficiently supplied with liquid	Refer to the LP FAULT section Increase subcooling
Very high discharge temperature, High amps measured at compressor	Very high superheat, very hot compressor	Reduce the superheat on the expansion valve. Check the pressure drop on the filter drier in the suction line
	Four Way reversing valve possibly blocked, abnormal noise from the valve, low LP and increasing HP	Check the operation of the valve by going through cycle inversions. Change if necessary. Refer to LP FAULT

INDOOR FAN BLOWER		
FAULT	POSSIBLE CAUSE AND SYMPTOMS	SOLUTION
High amps on action Fan motor	Pressure drop in the ducting installation too low.	Reduce the rotation speed of the fan Measure and estimate the airflow and pressure and compare with the specification from customer.
High level of vibration	Loosening of the fan or degradation of the silent blocks	Check the fixing of the fan and transmission kit
Unstable running and high vibration	Fan jumping from one operating point to the other	Change rotation speed of the fan

OUTDOOR AXIAL FAN		
FAULT	POSSIBLE CAUSE AND SYMPTOMS	SOLUTION
Circuit breaker open	High Amps due to a low voltage from the main supply	Check the voltage drop when all components are running. Change the circuit breaker
	High amps due to freezing of the coil	Adjust the defrost cycle set points
	Water ingress in the motor connection box	Change the component

ELECTRICAL HEATER		
FAULT	POSSIBLE CAUSE AND SYMPTOMS	SOLUTION
High Temperature trip out on the safety thermostat of the electric battery module	Low airflow rate	Measure and estimate the airflow and pressure and compare with the specification from customer.
	Safety thermostat malfunction	Check the operating status of the safety thermostat of the electric battery module

WATER INFILTRATION		
FAULT	POSSIBLE CAUSE AND SYMPTOMS	SOLUTION
Water found in the ventilation section	Cooling mode: Water carried away from the coil because of excessive airflow and speed on the coil.	Check the air flow rate and reduce it if necessary
	Low air pressure in the compartment due to a high airflow rate or a high pressure drop before the fan	Check filter Reduce airflow rate
	Degraded ventilation section seals	Check the door seal Check for the presence of seals in the corners of the door and at the bottom of the refrigeration section bulkhead.
Water ingress in the filter compartment	Water ingress through a leaking fresh air hood or when running 100% fresh air	Check the seals and flanges in the fresh air hood Reduce the airflow rate if necessary

CLIMATIC DISPLAYS		
FAULT	POSSIBLE CAUSE AND SYMPTOMS	SOLUTION
Nothing is written on the screen but it's enlightened	Possible problem of display addressing'	See Climatic control manual for more information
Nothing occurs on the unit or an option disappeared	Possible problem of units' configuration	See Climatic control manual for more information
The message "no link" appears	Problem of addresses' recognition	Check the connections and wiring (pay attention to the polarity of the display power supply). Check the displays

REFRIGERANT PROBE		
FAULT	POSSIBLE CAUSE AND SYMPTOMS	SOLUTION
The unit is stopped and does not want to restart	Refrigerant leak detected	Perform leak detection, repair the leak, recharge the unit, reset the detector
	Faulty sensor or sensing element	Check the LED status of the sensors. Refer to paragraph R32 sensor for the meaning of the LEDs.

MAINTENANCE PLAN

Rooftops are generally placed on the roof but can also be installed in technical rooms. These units are very robust but minimum regular maintenance is required. Some moving parts in the units can suffer from wear and tear and must be checked regularly (belts). Other parts can get clogged by dirt carried in the air (filters) and must be cleaned or replaced.

These units are designed to produce cooled or heated air through the use of a refrigeration vapor compression system, it is therefore imperative to monitor the refrigeration circuit operating pressures and check the pipe-work for leaks.

The table below, details a possible maintenance plan, including the operations to be carried out and the periodicity at which they must be accomplished. It is recommended to follow such a plan to keep a rooftop unit in good working order. Regular maintenance of your rooftop will extend its operating life and reduce operating faults

Symbols and Legend:

- **Operation which can be carried out by on-site maintenance technicians.**

- | **Operation which must be carried out by qualified refrigeration personnel, trained to operate on this type of equipment**

NOTE:

- Times are given for information purpose only and may vary depending on the unit size and type of installation.
- Coil cleaning must be carried out by qualified personnel using appropriate methods that won't damage the fins or the tubes.
- It is recommended to keep a minimum stock of common replacement parts in order to be able to carry out regular maintenance operations (i.e. filters). You can contact your local Lennox representative which can assist you in establishing a parts list for each type of equipment.
- The access ports to the refrigeration circuits MUST be leak checked every time gauges are connected to the service ports

Task	Operating mode	Monthly	+ Quarterly	+ Half Yearly
Clean or replace filters: Disposable, or metal frame.	Replace filters with new ones if disposable. Vacuum clean or blow the dirt. Wash and dry carefully. Replace filter if necessary by an original Lennox filter. Blocked filter will reduce the performance of the unit. THE UNIT SHOULD NEVER BE OPERATED WITHOUT FILTERS	•		
Visual check of the oil level (applicable for units equipped with sight glass) and check the oil for acidity on the refrigerant circuits	Visually check the oil level through the sight glass on the side of the compressor casing Test the oil every 3 years and after each intervention on the refrigerant circuit	•		
Clean condensate drains, indoor coils and outdoor coils (following local regulations)	It's mandatory to clean the external coils, according to the environment where the unit is located, the frequency of the cleaning varies from once in a month to minimum twice in a year. The performance and the sustainability of the machine is based on the perfect heat exchange. The use of a neutral pH cleaning product is mandatory. (WARNING: Fins and copper tubes are very fragile! Any damage WILL reduce the performances of the unit).			
Check condenser fans	Check the rotation of the fan (free rotation, detection of vibrations or bearing noises) Check for the Amps consumed on all three phases; compare it with the nominal value given in the electrical wiring diagram. Check the status of the fan blades and its protections.			
Check for the Amps consumed	Check for the Amps consumed on all three phases; compare with the nominal value given in the electrical wiring diagram.			
Check Smoke detector	Start the unit. Trigger the smoke detector with an aerosol tester. Reset unit and control.			
Check CLIMATIC™ control, set-points and variables	Refer to the commissioning sheet; Check all set points are set according to this document.			
Check refrigeration system for proper functioning	Retrieve/Check the values of Overheating and subcooling			
Check clock settings	Check the time and date of the control		•	
Check the position and tightness of refrigeration components	Check systematically all connections and fixings on the refrigeration circuit. Check for oil traces, eventually a leak test should be conducted. Check operating pressures correspond to the ones, indicated on the commissioning sheet			
Check three-way valve on HWC (If applicable)	Increase room set-point 10°C above the actual room temperature. Check operation of the piston. It must move away from the valve head. Reset the control.			
Check the position of the crankcase heaters (around the compressor) and the proper functioning of it	Check the well fixation of the crankcase heaters, if it is tight enough And check the crankcase heaters overall working.		•	
Check defrost cycle with 4-way valve inversion.	Switch the unit to heat pump mode. Change the set point to obtain the standard defrost mode and reduce the cycle time to the min value. Check the operation of the defrost cycle.			

Task	Operating mode	Monthly	+ Quarterly	+ Half Yearly
Check overall working of the flow controller (only for rooftops with water condensation function)	Cut-off the compressors, stop the water circulation, then start the unit, wait for the water flow failing signal in the controller.			
Check the water flow (only for rooftops with water condensation function)	Measure the water flow and compare it to the initial value set in the command selection			
Check the blower plug fans (freewheel)	Check the rotation of the fan (free rotation, detection of vibration or bearing noises) Check for the Amps consumed on all three phases; compare with the nominal value given in the electrical wiring diagram.			•
Check the axial extractor fan (if the unit is equipped with)	Check the rotation of the fan (free rotation, detection of vibration or bearing noises) Check for the Amps consumed on all three phases; compare with the nominal value given in the electrical wiring diagram.			
Check the well working of the energy recovering wheels	Check the rotation of the wheel; Check the strap tension; Replace the components in case of malfunctioning			
Check Airflow rate safety switch (if equipped).	Shut down supply fan. The fault must be detected within 5 seconds.			•
Check freeze protection on HWC (if applicable)	Test antifreeze function (leakage rate, frost protection thermostat)			
Check economizer actuator operation	Check all fixings and transmission. Stop the unit using the control. The fresh air damper must close. Start the unit, the fresh air damper should open. Make a forced opening and closure of the motorized dampers.			
Check tightness of all electrical connections	Power down the unit and check and tighten all screws, terminal and electric connections (including the terminal boxes) When turning on the unit, check the deterioration of the electrical components with a thermal camera, with the unit working at 100% of its power.			
Check HP safety switches	Install a pressure gauge HP and check if the safety switches overall working.			
Check the value of the analog sensors	Install the pressure gauge calibrated to check the analog sensors. Install a thermometer calibrated to control the sensors. Check with a calibrated anemometer the flow rate displayed by CLIMATIC			
Check the position of all sensors	Check the position and fastening of all sensors and their accessories (pressure tapping tube).			•
Check and clean if necessary all fresh air grids	Check the fresh air grilles (if fitted). If dirty or damaged, remove them from unit and clean with high pressure water cleaner. Refit on unit once clean and dry.			•
Check electric heater element for excessive corrosion	Turn off the unit; Pull the electric heater out of the heater module box and check the resistances of traces of corrosion; Replace resistance as required;			
Check anti-vibration mountings, for wear and tear.	Visually check anti-vibration mountings on compressors and centrifugal fan. Replace if damaged.			•

Task	Operating mode	Monthly	+ Quarterly	+ Half Yearly
Check Glycol concentration in the HWC circuit and/or in the water condenser circuits	Check the glycol concentration in the pressurized water circuit. (a concentration of 30% gives a protection down to approx.. - 15°C) check the circuit pressure			
Gas burner module check for corrosion	Pull out the burner to access the tubes (refer to Gas burner section in the IOM)			
Sweeping and cleaning the gas burner	Clean the in-shot burners and the blower wheel lightly with a brush. Sweep the flue and flue box. Wipe-off the dust from the housing of the motor. Clean combustion air inlet louvers Pull-out baffles from the tubes, sweep the tubes CHECK FLUE BOX GASKET			
Gas supply pressures / connections checks	Refer to Gas burner section in the IOM for details			
Check the gas regulation valve settings	Refer to Gas burner section in the IOM for details			
Check gas burner safety switches	Refer to Gas burner section in the IOM for details			
Check the ignition electrode and the ionization probes	Refer to Gas burner section in the IOM for details			
Check gas fume combustion levels	Do a combustion analysis. Refer to local regulation if it exists			
Check casing and equipment corrosion	To treat and neutralize eventual rust spots			•
Check the water tightness of the unit and its accessories	Verify the gaskets, if cracked or ripped, repair them or replace them.			•
Check the doors gasket	Verify the gaskets; if cracked, ripped or discontinuous in these cases replace them.			•
Check and clean the water filter (only for Rooftops with water condenser)	ATTENTION: The water circuit can be under pressure. Follow the usual precautions when depressurizing the circuit before opening. Ignoring these rules can lead to accidents and cause injury to the personal.			
Check the water tightness of the water circuit (only for Rooftops with water condenser)	Check for water leaks and repair if it's needed.			•
A2L: Calibrate the sensitive elements of the sensors	Perform a sensor calibration. This calibration is mandatory and the frequency varies according to local standards. To recalibrate this sensor, please contact our local Lennox Service (specific terminal usable by our authorized technicians)			
Replacement of the A2L probe	Check the remaining sensor life. Sensitive element to be replaced every 5 years.			
A2L alarms test	Access the test button inside the box . In case of negative test, contact your local Lennox Service			

WARRANTY

TERMS AND CONDITIONS

In the absence of any other written agreement (e.g. local regulations), the guarantee shall only apply to design faults which occur within a 24 months for an R32 machine and 12 months for an R410 machine (warranty period).

The warranty period starts on the date of commissioning and at the latest six months after the delivery of the Rooftop.

DO NOT CONFUSE THE WARRANTY WITH MAINTENANCE

The warranty will only apply if a maintenance contract has been signed, starting from the date of commissioning, and if the maintenance contract has actually been performed.

The maintenance contract must be made with a specialist, competent company.

The sole effect of any repair, modification or replacement of an item during the warranty period must be to extend the material's warranty period.

Maintenance must be carried out in accordance with regulations.

In addition to annual checks, safety accessories for non-toxic fluids must be requalified (calibrated or replaced) every 12 months, according to the CTP of 23 July 2020.

If a spare part is supplied after the expiry of the warranty period, it shall be guaranteed for a period equal to the initial warranty period and will be subject to the same conditions.

We recommend for a contract four inspections per year (every three months), before the start of each season, in order to check the operation of the equipment in the various operating modes

LIFETIME OF THE EQUIPMENT

The refrigerating system is designed for a lifetime of at least 10 years if the safety and maintenance instructions are strictly respected.

The lifetime of the equipment may be renewed if the periodic requalification certificate is validated by the expert (authorized body or DREAL in France (Directions Régionales de l'Environnement, de l'Aménagement et du Logement))

DISPOSAL OF THE EQUIPMENT

Equipment shut-down and recuperation of oil and coolant must be carried out by qualified personnel conform to the recommendations of standard EN 378.

All elements in the refrigeration system such as refrigerant, oil, coolant, filters, dryers and insulating materials must be recuperated, re-used and/or disposed of in a correct manner (see EN 378 part 4). No materials may be discarded into the environment.

The Ecologic organization is in charge of collecting, depolluting and recovering WEEE throughout France, ensuring that each step is carried out in full compliance.

Due to LENNOX EMEA ongoing commitment to quality, the specifications, ratings and dimensions are subject to change without notice and without incurring liability. Improper installation, adjustment, alteration, service or maintenance can cause property damage or personal injury. Installation and service must be performed by a qualified installer and servicing agency.



brand of LENNOX EMEA

Headquarters LENNOX EMEA
7 rue des Albatros - Z.I. Les Meurières, 69780 Mions - France
+33 (0) 810 502 502
www.lennoxemea.com

