

INSTALLATION, OPERATING AND MAINTENANCE



AIR COOLED LIQUID CHILLER - HEAT PUMP

eCOMFORT2

20 - 190 kW

MIL160E-0720 07-2020



www.lennoxemea.com



LENNOX

TABLE OF CONTENTS

	Page
PREFACE	2
PED DECLARATION	3
F-GAS REGULATION	4
WARNING	5
DATA PAGE FOR UNIT COMMISSIONING	6
1. GENERAL CHARACTERISTICS	
1.1 Technical data	7 - 12
1.2 Electrical data	13
1.3 Component	14
1.4 Operation limits	15
1.5 Hydraulic system data	16 - 18
1.6 Pressure drop in the water system	19
1.7 Water flow	20
1.8 Piping drawings	21 - 28
1.9 Dimensions	29 - 37
2. INSTALLATION	
2.1 Transport-Handling	38
2.2 Site and shipping guidance	39
2.3 Unit lifting	39
2.4 Antivibration mounting	40
2.5 Weight distribution	41 - 42
2.6 Installation clearances	43 - 44
2.7 Unit installation	45 - 46
2.8 Electrical connections	48
2.9 Partial Heat Recovery	49
3. COMMISSIONING AND OPERATION	
3.1 Steps to follow for commissioning the units	50
3.2 Steps to follow for control setting	51 - 52
3.3 Checking the water flow rate	53
3.4 Water analysis	54
4. MAINTENANCE	
4.1 Preventive maintenance	55
4.2 Maintenance plan	56 - 58
4.3 Cleaning the condenser	59 - 60
4.4 Process for replacing a compressor on field	60
4.5 Corrective maintenance	61
4.5 Failure diagnosis	62
5. RISK ANALYSIS AND HAZARDOUS SITUATION ACCORDING TO PED DIRECTIVE	63 - 64
6. END OF THE MACHINE LIFE	64

CE Our company's products comply with European standards.

The manufacturing of eComfort units answers to ISO9001 control quality system and to ISO14001.



Units are certificated by EUROVENT



All the technical and technological information contained in this manual, including any drawing and technical descriptions provided by us, remain the property of Lennox and must not be utilised (except in the operation of this product), reproduced, issued to or made available to third parties without the prior written agreement of Lennox.

The specifications and technical characteristics in this booklet are given for information purposes. The manufacturer reserves the right to modify them without prior notice or obligation to modify in a similar manner, the equipments previously supplied.

LENNOX REFAC, SA, in its commient to preserve the environment, has an Environmental Management System based on ISO 14001, through which all environmental aspects generated during its activity are managed and continuously improved, taking into account the life cycle of the products we manufacture and market.

For this reason, you: customer, user and / or maintainer of the equipment, are invited to join our commient to conserve our environment, and follow the indications that we expose throughout this manual.

Original version is the English one. Other versions are translations

PREFACE

Please read this operating manual prior to commissioning the eComfort chiller. Familiarize yourself with the operation and control of the eComfort chiller and closely follow the instructions.

We would like to stress the importance of training with respect to the correct handling of the chiller. Please consult Lennox on the options available in this field.

It is important that this manual be stored in a permanent location in the vicinity of the eComfort chiller.

For the sake of clarity, important items in this manual are shown as follows:

This manual contains important instructions regarding the commissioning of the eComfort chiller. It also includes important instructions to prevent personal injury and damage to the machine during operation. Furthermore, in order to promote fault-free operation of the chiller, maintenance information has been included.

Please do not hesitate to contact one of our employees should you require further information on specific chiller subjects. Order related documentation will be forwarded under separate cover. This documentation consists of:

- **EU declaration**
- **Operating manual for control system**
- **Installation Operating manual**
- **Wiring diagram**
- **Unit detail are given on unit nameplate**

FOR NETHERLANDS: the STEK logbook, including the required certificates will be handed over by the installation technician or left with the machine following commissioning by Lennox. The data published in this manual is based on the most recent information available. It is supplied conditional to later modifications. We reserve the right to modify the construction and/or design of our eComfort chillers, at any time, without prior notification or obligation to adapt previous supplies accordingly.

Any work on the Chiller should be carried out by trained and licensed competent technician.

The following risks are present on the unit:

- **risk of electrical shock.**
- **risk of injury from rotating parts.**
- **risk of injury from sharp edges and heavy weight.**
- **risk of injury from high pressure gas.**
- **risk of injury from high and low temperatures components.**

Text	Important general instructions
	Danger of damage to the chiller

PED DECLARATION

All units are compliant with the following Directives, Norms and Standards:

- 2014/68/EU Pressure Equipment Directive
- 2006/42/CE Machinery Directive
- 2014/35/EU Low Voltage Directive
- 2014/30/EU Electro Magnetic Compatibility Directive
- EN378-1-2 :2009 -3-4- Refrigerating systems and heat pumps - Safety and environmental requirements
- 2011/65/EU The European Restriction of the Use of Certain Hazardous Substances (RoHS)
- « WEEE », 2012/19/EU –Directive on waste electrical and electronic equipment
- 2009/125/EC Ecodesign • EN-378-1-2:2009-3-4. • EN-60204-1. And is provided with CE markings (on the condition that the necessary options are present) (for further information see EU declaration).

SAFETY RELIEF

This equipment is protected with safety pressure relief calibrated at 42,7 bar g and safety pressure switch calibrated at 42 bar g. Do not overcome this operating pressure.

IMPORTANT NOTICE

All work on the unit must be carried out by a qualified and authorised employee.

Non-compliance with the following instructions may result in injury or serious accidents.

Work on the unit:

- The unit shall be isolated from the electrical supply by disconnection and locking using the main isolating switch.
- Workers shall wear the appropriate personal protective equipment (helmet, gloves, glasses, etc.).

Work on the electrical system:

- Work on electric components shall be performed with the power off (see below) by employees having valid electrical qualification and authorisation.

EMC DIRECTIVE COMPLIANCE

WARNING:

This equipment is an “A class” according CEM Directive. In an industrial environment, this device can create radio electrical noise. In this case, the owner can be asked to take appropriated actions.

This applies to all machine installed with nominal amps below <75A:

- The short-circuit rate $R_{sce}=33$ is defined in the EN61000-3-12 standard relative to the harmonics readings on the supply network. The appliances compliant with the harmonic current limits equivalent to $R_{sce}=33$ can be connected in whatever connection point of the main supply system.
- The maximal allowable impedance of the main supply system $Z_{max}=0.051W$ is defined by EN 61000-3-11 standard relative to the voltage variation, fluctuation and flicker readings. The connection to the supply is a conditional connection submitted to the preliminary agreement of the power supply local provider.

Work on the refrigerating circuit(s):

- Monitoring of the pressures, draining and filling of the system under pressure shall be carried out using connections provided for this purpose and suitable equipment.
- To prevent the risk of explosion due to spraying of coolant and oil, the relevant circuit shall be drained and at zero pressure before any disassembly or unbrazing of the refrigerating parts takes place.
- There is a residual risk of pressure build-up by degassing the oil or by heating the exchangers after the circuit has been drained. Zero pressure shall be maintained by venting the drain connection to the atmosphere on the low pressure side.
- The brazing shall be carried out by a qualified brazer. The brazing shall comply with the standard NF EN1044 (Minimum 30% silver).

Replacing components:

- In order to maintain CE marking compliance, replacement of components shall be carried out using spare parts, or using parts approved by LENNOX.
- Only the coolant shown on the manufacturer’s nameplate shall be used, to the exclusion of all other products (mix of coolants, hydrocarbons, etc.).

CAUTION: In the event of fire, refrigerating circuits can cause an explosion and spray coolant gas and oil.

F GAS REGULATION

Operators of refrigeration equipment's must comply with the obligations defined in:

- EU Regulation No 517/2014 on fluorinated greenhouse gases
- EC 1005/2009 on substances that deplete the ozone layer

	<p>Non compliance with these requirements is an offence and liable of financial penalties.</p>
	<p>Moreover, in case of problem it is mandatory to prove to the insurance company that the equipment complies with the F gas Regulation</p>

WARNING

1.2 - Warning labels

The chiller is marked with the following warning labels to alert to potential hazards (on or near the potentially hazardous part).

High temperatures	Electrical Voltage	Rotating parts	Sharp parts

Regularly check that the warning labels are still in the correct positions on the machine and replace them if necessary.



WARNING

1. **Attention:** The high-pressure safety switches are essential elements which guarantee the system remains within the admissible operating limits. Before switching on the installation, always ensure all electrical connections are correct on these elements which are used to isolate the electrical power supply to the compressor(s) they protect. Carry out a test to ensure the electrical power supply is effectively isolated when the pressure switch attains its set value.
2. In case of installation in a seismic zone or in a zone which may be effected by violent natural occurrences such as storms, tornados, floods, tidal waves, etc..., the installer and/or operator will refer to valid standards and regulations in order to ensure the devices required are available as our units are not designed to operate under such conditions without prior precautions.
3. The equipment is not designed to resist fire. The installation site will therefore have to respect valid standards with regard to protection against fire (emergency instructions, map...).
4. In case of exposure to corrosive external atmospheres or products, the installer and/or operator shall take the necessary precautions to avoid damage to the equipment and will make sure the equipment provided has the necessary and sufficient anti-corrosion protection.
5. To respect a sufficient number of supports for the piping according to their size and weight under operating conditions and to design the piping to avoid a water hammer phenomenon
6. For technical reasons, it is not possible to carry out hydrostatic tests on all our units so leak tests are carried out as a compensatory measure. (The entire circuit is checked using leak detectors). For machines charged with refrigerant, at the end of the test, an HP test is carried out in the factory to make sure the pressure switch is working properly.
7. Before any work is carried out on the refrigeration circuit, the dry air or nitrogen pressure our units are supplied with must be released (For units not charged with refrigerant in the factory.)
8. The emissions of refrigerant via the safety relief valves must be channeled to the exterior of the machine room. The outlet relief valve will have to be sized in compliance with EN13136.
9. Installation and maintenance of these machines must be carried out by personnel qualified to work on refrigeration equipment.
10. All interventions must be carried out in conformity with valid safety regulations (e. g.: NF EN 378), as well as the recommendations indicated on the labels and handbooks provided with the machine. All actions shall be taken to avoid access of unauthorized persons.
11. It is essential that any pipework or other components of the refrigeration circuit hazardous to people because of their surface temperature are insulated or identified.
12. Ensure that the installation zone (room or area) of the machine has restricted access and ensure the good condition of the covering.
13. The risk of inadvertent discharge is minimized.

DATA PAGE FOR UNIT COMMISSIONING

Unit:		Serial no. :	
Control panel identification code			
Installation address:			
Installer:		Installer tel. :	
Installer address:			
Date of commissioning:			
Checks:			
Supply voltage:		Rated voltage of the unit :	

	YES	NO
Unit on rubber antivibration mounts		
General power supply connection		
Control panel connection (option)		
Compressor oil level indicator		
Hydraulic connection		
Purged of the installation		

DATA INPUT		COOLING CYCLE	HEATING CYCLE
Air Input Temperature, Coil	°C		
Water Output Temperature	°C		
Water Input Temperature	°C		
High Pressure			
Low Pressure			

ELECTRIC POWER CONSUMPTION		COOLING CYCLE			HEATING CYCLE		
Compressor 1	A						
Fan 1	A						
Compressor 2	A						
Fan	A						
Compressor 3	A						
Fan 3	A						
Compressor 4	A						
Fan 4	A						

Options Installed:	
Comments:	

1.- GENERAL CHARACTERISTICS

1.1.- TECHNICAL DATA

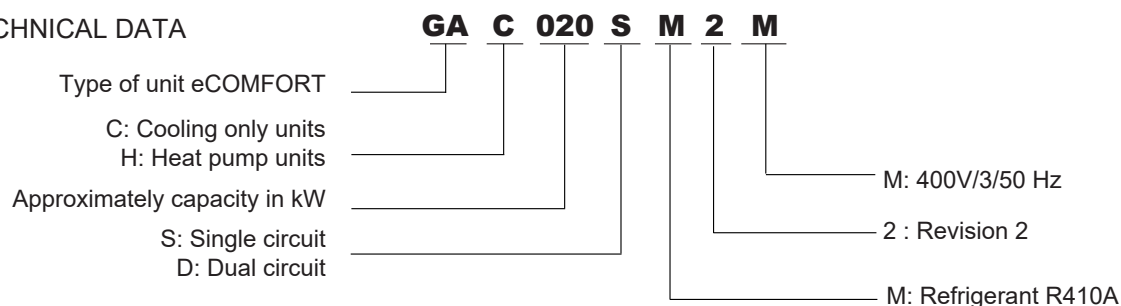

OPTIONS	
LNCJ	Low noise : Acoustic compressor jacket
SEAS	Variable air flow control with standard EC fans
HIFP	Variable air flow control with high pressure EC fans
ACTR	LenGuard anti-corrosion condenser coil treatment
CPGR	Coils protection : metallic grille
LLWT	Low leaving water temperature down to -12°C
PHRF	Domestic hot water supply : desuperheater
RLKD	Refrigerant leak detection
SPLP	Hydraulic module with low-pressure single pump
DPLP	Hydraulic module with low-pressure twin pump
SPEL	Hydraulic module with eDrive low-pressure single pump
DPEL	Hydraulic module with eDrive low-pressure twin pump
SPHP	Hydraulic module with high-pressure single pump
DPHP	Hydraulic module with high-pressure twin pump
SPEH	Hydraulic module with eDrive high-pressure single pump
DPEH	Hydraulic module with eDrive high-pressure twin pump
BYVC	Bypass Valve for delta P control with eDrive pump (supplied loose)
WTNG	Water tank
WTHS	Water tank electrical heater Standard
WTHH	Water tank electrical heater High
EWFS	Electronic flow switch
WFIF	Water filter (supplied loose)
KGRL	Flange connection (supplied loose)
APEP	Antifreeze protection on exchangers and pipings down to -20°C
APPP	Antifreeze protection on exchangers, pump(s) piping down to -20°C
APPW	Antifreeze protection on exchangers, pump(s) piping and water tank down to -20°C
ECLO	LonWorks® interface FTT10
BNET	BACnet® interface MSTP
MBUS	ModBus interface RS485
MBIP	ModBus and BACnet® interface TCP/IP
DM60	Remote advanced display (supplied loose)
DS60	Service display (supplied loose)
DCBO	Remote control : customer drive contact input/output
ELME	Electric energy meter
PHCT	Phase reversal protection
POWF	Power factor correction
SOFT	Soft starter
EBFM1	Electrical box upgrade ventilation : 1 fan
EBFM2	Electrical box upgrade ventilation : 2 fans
ALWA	Aluminum wires adaptor (supplied loose)
AVUB	Rubber anti-vibration mounts type (supplied loose)
SLCR	Wooden crate for long distance

NOTE: When it is possible options supplied loose should be included in a carton box inside the unit

1.1.- TECHNICAL DATA

COOLING ONLY

GAC MODELS		020S	025S	030S	035S	040S	045S	055S	060S	070S	080S
Cooling capacity (*)	Kw	20,1	24,6	31,7	36,9	40,1	45,5	54,8	61,2	69,5	82,7
Number of compressors		2 / Scroll						2 / Scroll			
Hydraulic connections		1 1/2"						2"			
Nominal water rate	m ³ /h	3,5	4,2	5,5	6,4	6,9	7,8	9,4	10,5	12,0	14,2
Net weight	Kg	312	319	342	366	371	386	602	627	657	706
Refrigerant R410A load	Kg	4,0	4,2	4,4	4,6	4,8	5,2	7,0	8,0	8,5	10,0

GAC MODELS		090S	110S	125S	110D	125D	140D	160D	185D
Cooling capacity (*)	Kw	91,3	106,7	122,3	105,6	123,2	138,8	162	185
Number of compressors		3 / Scroll			2+2 / Scroll		2+2 / Scroll		3+2 / Scroll
Hydraulic connections		2 1/2"					3"		
Nominal water rate	m ³ /h	15,7	18,4	21,0	18,2	21,2	23,9	27,9	31,8
Net weight	Kg	876	892	892	989	1000	1401	1508	1575
Refrigerant R410A load	Kg	12,5	13,5	14,0	13,0	13,6	16,0	16,6	16,8

HEAT PUMP

GAH MODELS		020S	025S	030S	035S	040S	045S	055S	060S	070S	080S
Cooling capacity (*)	Kw	20,0	24,4	31,0	36,4	39,4	44,7	54,0	60,1	68,4	81,4
Heating capacity (**)	Kw	19,8	24,5	31,9	36,7	39,2	44,6	53,6	61,3	67,6	79,3
Number of compressors		2 / Scroll						2 / Scroll			
Hydraulic connections		1 1/2"						2"			
Nominal water rate	m ³ /h	3,4	4,2	5,3	6,3	6,8	7,7	9,3	10,3	11,8	14,0
Net weight	Kg	335	341	370	394	400	421	645	683	715	773
Refrigerant R410A load:	Kg	7,4	7,6	8,8	9,2	9,4	9,6	14,0	18,0	18,4	19,0

GAH MODELS		090S	110S	125S	110D	125D	140D	160D	185D
Cooling capacity: (*)	Kw	90,5	105,6	120,4	104,7	121,0	136,5	159,3	181,4
Heating capacity: (**)	Kw	91,2	103,4	118,1	106,3	121,1	135,8	157,2	174,5
Number of compressors:		3 / Scroll			2+2 / Scroll		2+2 / Scroll		3+2 / Scroll
Hydraulic connections:		2 1/2"					3"		
Nominal water rate:	m ³ /h	15,6	18,2	20,7	18,0	20,8	23,5	27,4	31,2
Net weight:	Kg	927	995	995	1061	1073	1483	1592	1663
Refrigerant R410A load:	Kg	25,0	27,0	27,3	27,6	29,0	35,0	37,0	38,0

(*) Cooling capacity: Outside temperature: 35°C / Inlet/outlet water temperature: 12/7°C

(**) Heating capacity: Outside temperature: 7°C DB / 6°C WB / Inlet/water outlet temperature: 40/45°C

1.- GENERAL CHARACTERISTICS

1.1.- TECHNICAL DATA

HYDRAULIC CIRCUIT

GAC/GAH		020S	025S	030S	035S	040S	045S	055S	060S	070S	080S
Low pressure pump	Type	Stainless steel threaded centrifugal pumps									
High pressure pump											
Expansion vessel	Type	Fixed membrane expansion vessel									
	Max. pressure (bar)	3.5					3.5				
	Volume (dm ³)	18					35				
Buffer tank	Type	Isolated steel tank									
	Safety valve set (bar)	3.5					3.5				
	Volume (dm ³)	100					175				

		090S	110S	125S	110D	125D	140D	160D	185D
Low pressure pump	Type	Stainless steel threaded centrifugal pumps							
High pressure pump									
Expansion vessel	Type	Fixed membrane expansion vessel							
	Max. pressure (bar)	3.5				3.5			
	Volume (dm ³)	35				50			
Buffer tank	Type	Isolated steel tank							
	Safety valve set (bar)	3.5				3.5			
	Volume (dm ³)	GAC: 175		250		400			
		GAH: 250							

(***) Only in units with Hydronic module

FAN DATA

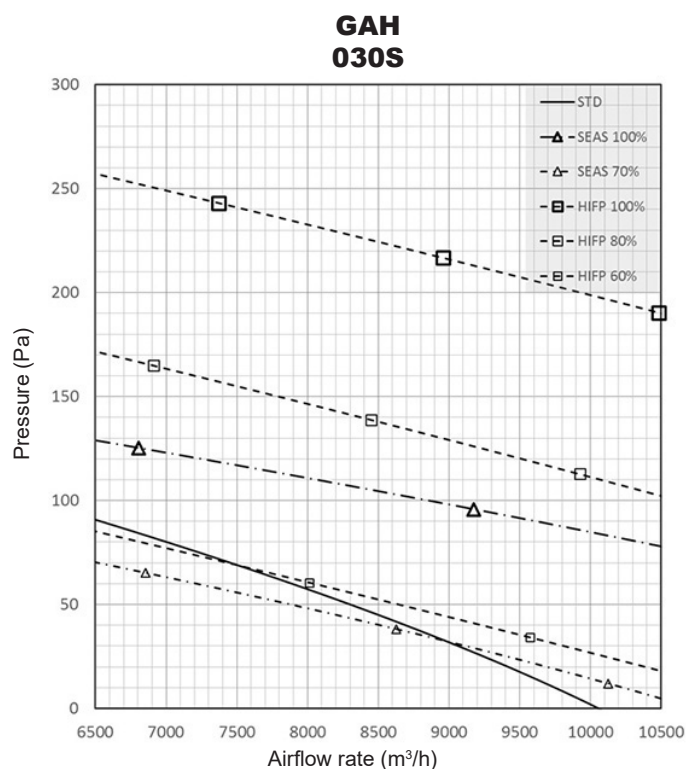
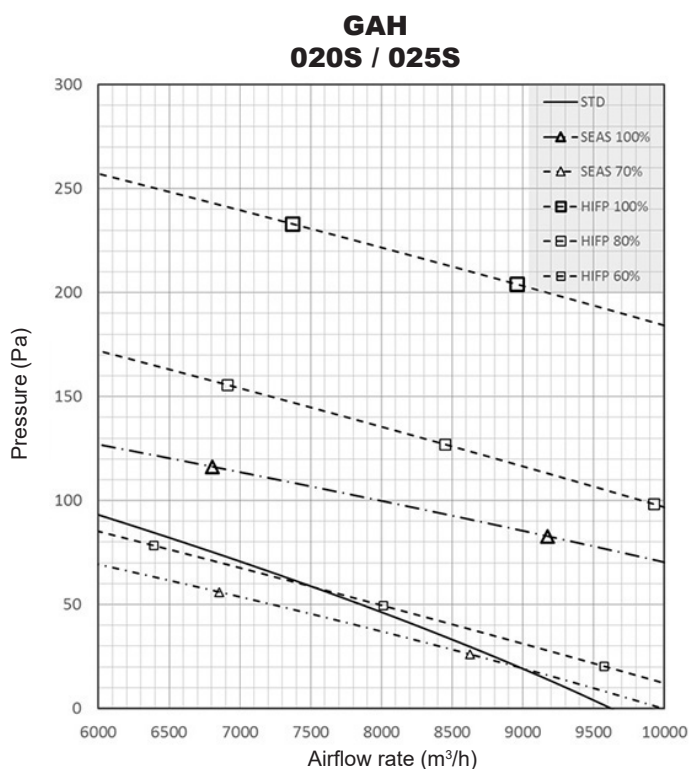

1.- GENERAL CHARACTERISTICS

1.1.- TECHNICAL DATA

FAN DATA

**GAH
035S / 040S / 045S**

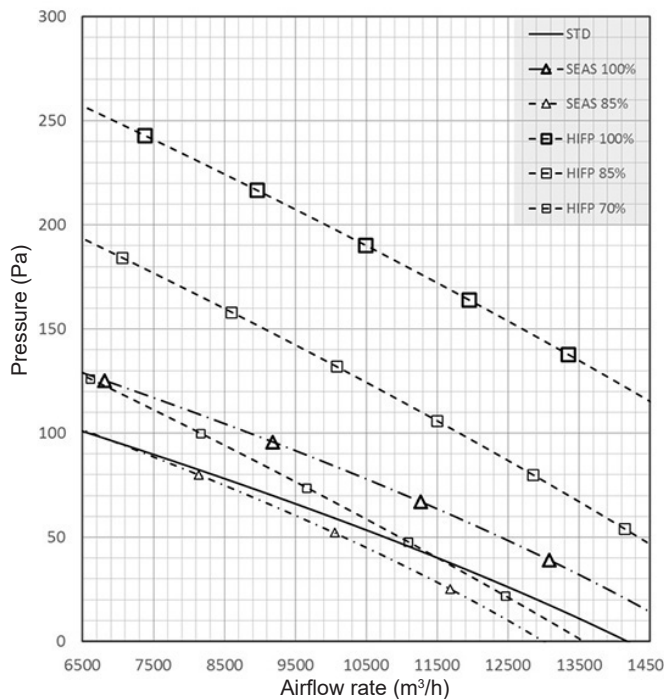

**GAH
055S**

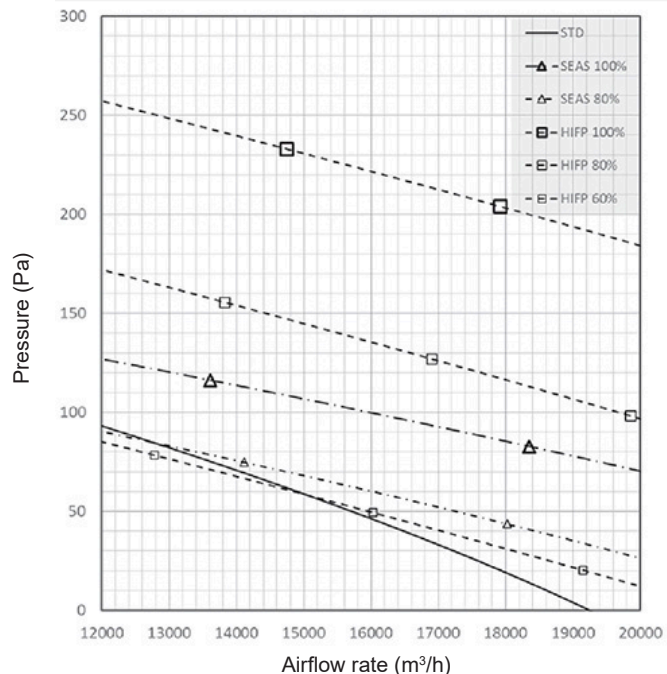

**GAH
060S / GAH070S**

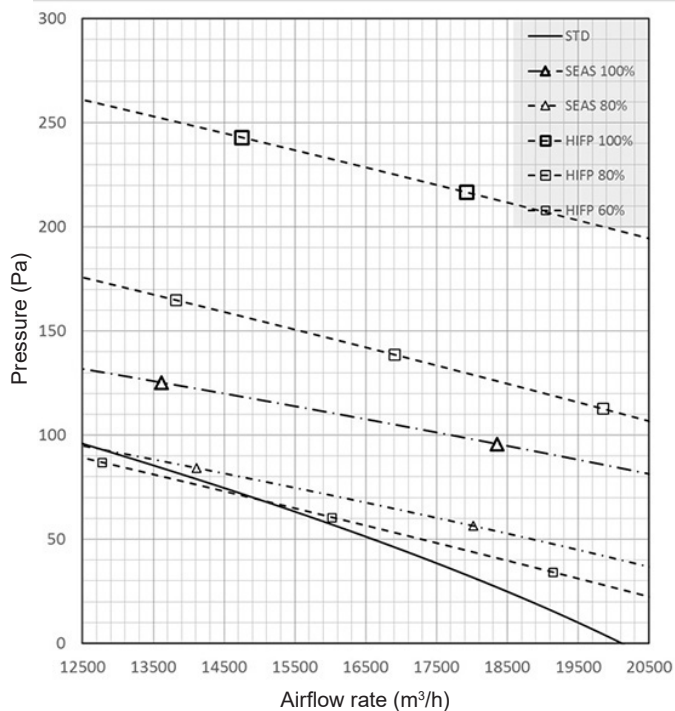

**GAH
080S**

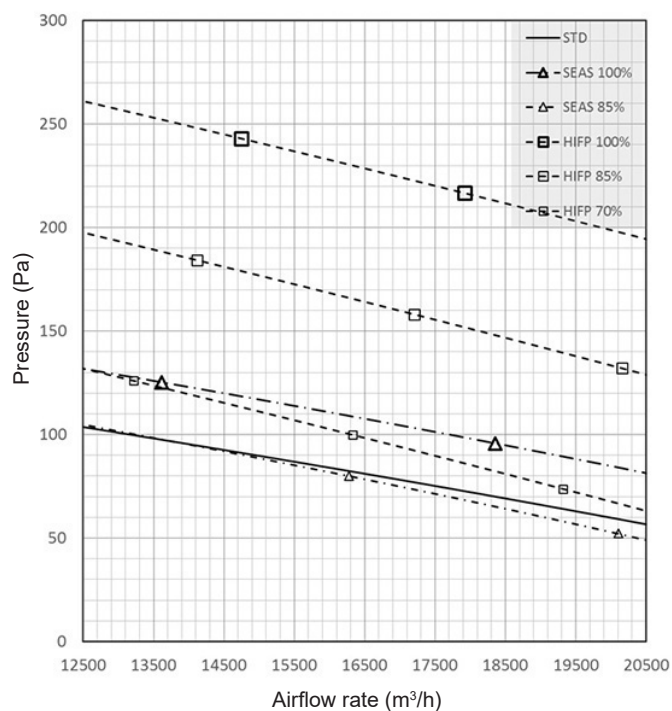

1.- GENERAL CHARACTERISTICS

1.1.- TECHNICAL DATA

FAN DATA

GAH 090S

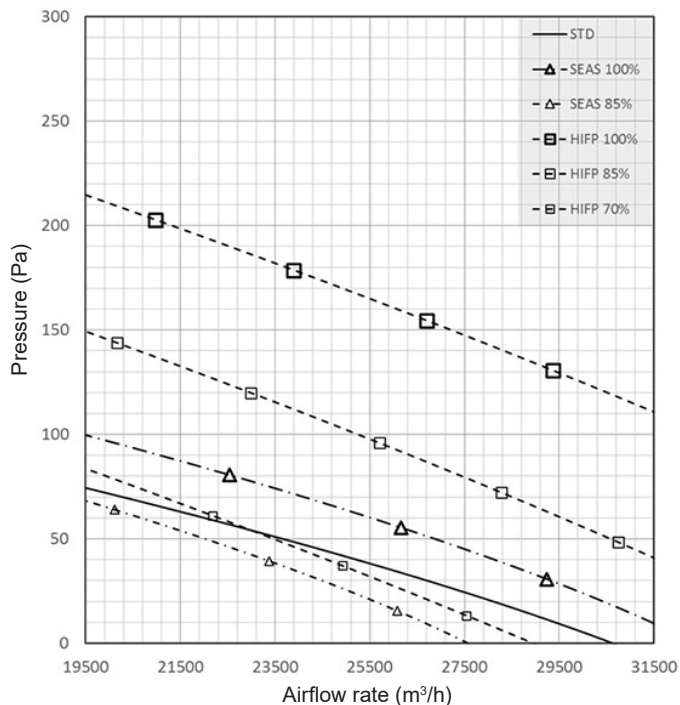

GAH 110S / 125S

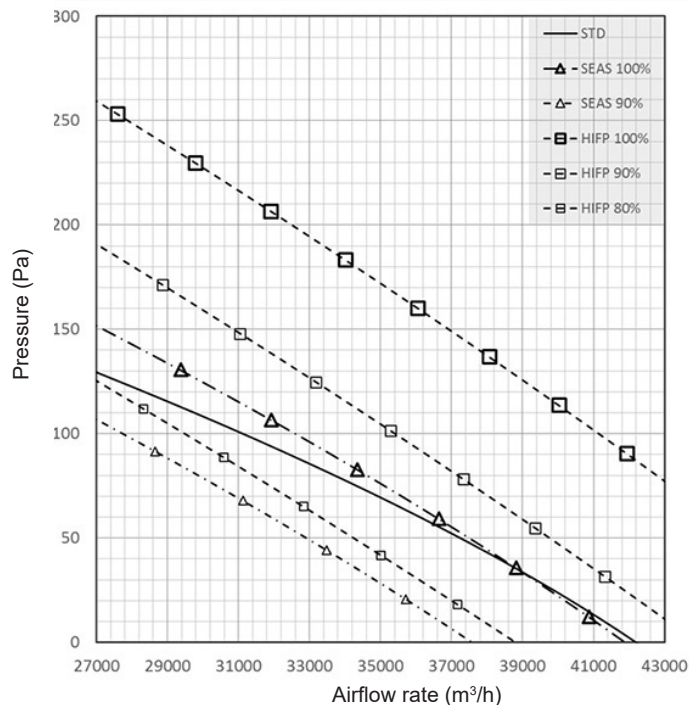

GAH 110D

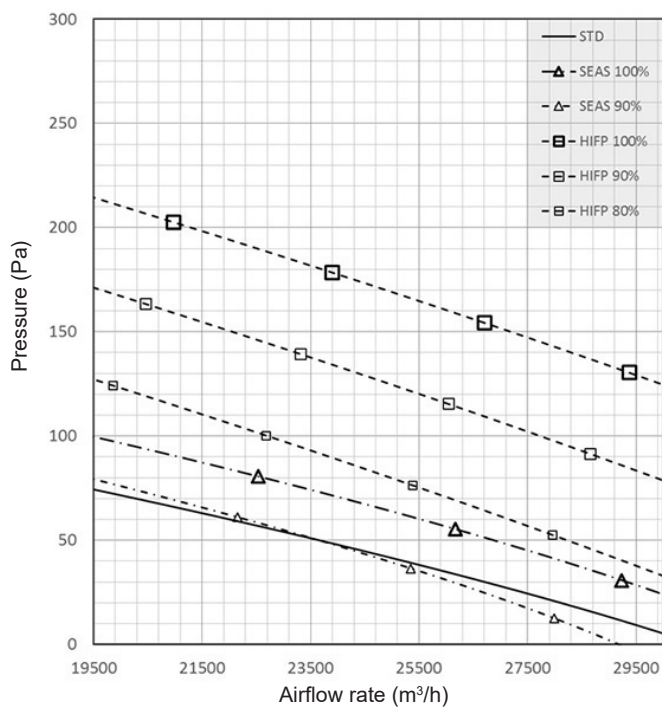

GAH 125D

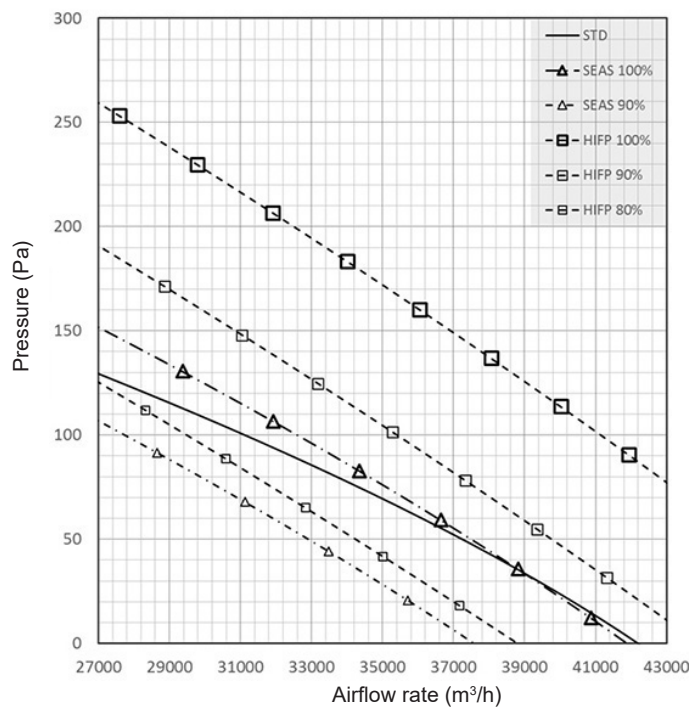

1.- GENERAL CHARACTERISTICS

1.1.- TECHNICAL DATA

FAN DATA

GAH 140D

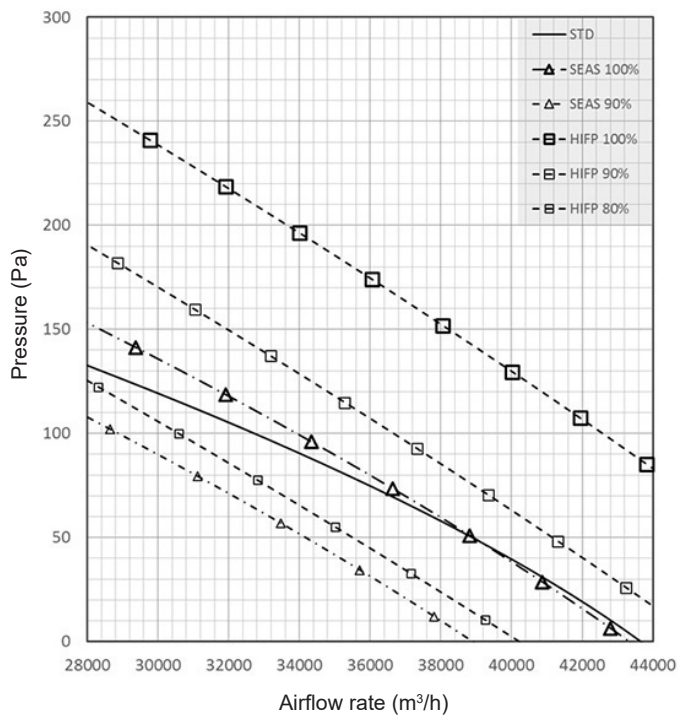

GAH 160D

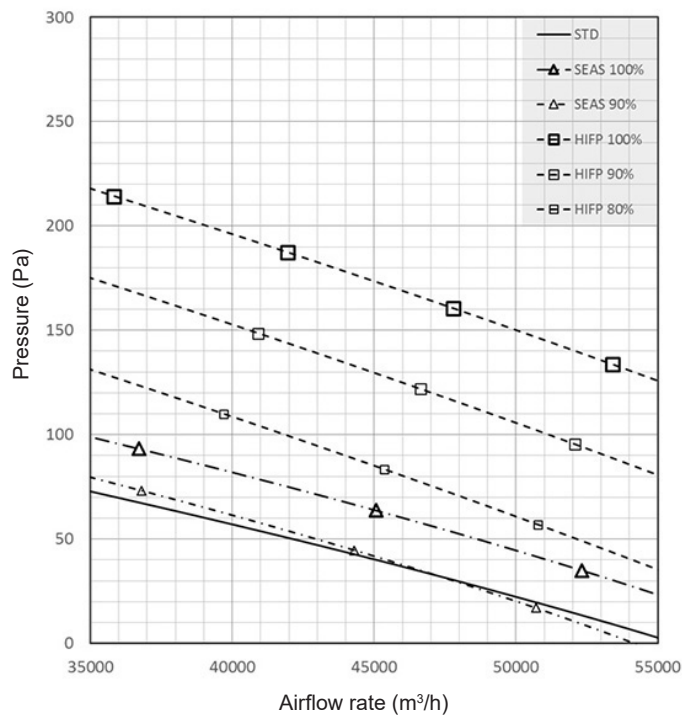

GAH 185D

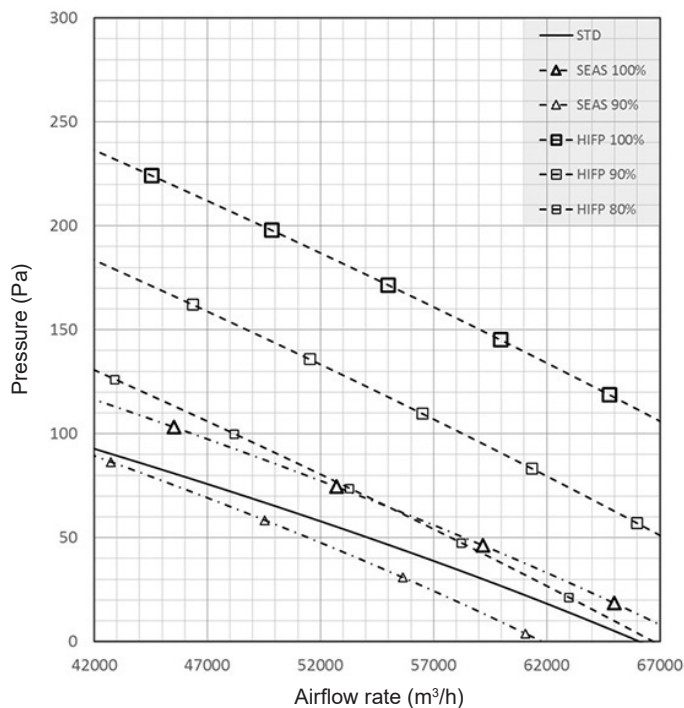

NOTE: For GAC units consider 3% more of airflow

1.- GENERAL CHARACTERISTICS

1.2.- ELECTRICAL DATA

GAC/GAH		020S	025S	030S	035S	040S	045S	055S	060S	070S	080S
Maximun power	kW	9,94	12,22	15,32	17,63	18,21	20,99	25,1	28,00	30,90	35,78
Maximun current	A	16,57	18,8	25,79	31,25	30,47	37,05	42,22	47,03	51,84	68,14
LRC											
Starting current	A	52,11	61,74	88,72	117,96	117,57	147,86	140,56	162,56	167,37	210,54
Starting current with SoftStarter	A	34,91	41,14	58,72	77,56	77,17	96,66	93,36	106,56	111,37	140,94
SEAS FAN											
Additional power	kW	0,24	0,24	0,24	-0,05	-0,05	-0,05	0,48	0,48	0,48	-0,1
Additional current	A	0,2	0,2	0,2	-0,82	-0,82	-0,82	0,4	0,4	0,4	-1,64
HIPF FAN											
Additional power	kW	1,1	1,1	1,1	0,81	0,81	0,81	2,2	2,2	2,2	1,62
Additional current	A	1,5	1,5	1,5	0,48	0,48	0,48	3	3	3	0,96
LOW PRESSURE WATER PUMP											
Additional power	kW	0,57	0,57	0,81	0,81	1,35	1,35	1,35	1,35	1,35	1,35
Additional current	A	1,37	1,37	1,59	1,59	2,45	2,45	2,45	2,45	2,45	2,45
HIGH PRESSURE WATER PUMP											
Additional power	kW	1,35	1,35	1,73	1,73	1,73	1,73	1,73	1,73	1,73	1,73
Additional current	A	2,45	2,45	3,15	3,15	3,15	3,15	3,15	3,15	3,15	3,15
ANTIFREEZE ELECTRICAL HEAT											
Additional power	kW	2,25	2,25	2,25	2,25	2,25	2,25	6	6	6	6
Additional current	A	3,25	3,25	3,25	3,25	3,25	3,25	8,66	8,66	8,66	8,66
STANDARD ELECTRICAL HEATER (GAH only)											
Additional power	kW	9	9	9	9	9	9	18	18	18	18
Additional current	A	12,99	12,99	12,99	12,99	12,99	12,99	25,98	25,98	25,98	25,98
HIGH ELECTRICAL HEATER (GAH only)											
Additional power	kW	12	12	12	12	12	12	24	24	24	24
Additional current	A	17,32	17,32	17,32	17,32	17,32	17,32	34,64	34,64	34,64	34,64
GAC/GAH		090S	110S	125S	110D	125D	140D	160D	185D		
Maximun power	kW	41,08	48,43	54,88	49,48	57,38	63,2	71,48	84,11		
Maximun current	A	69,75	81,96	103,35	83,83	96,81	106,48	136,08	149,85		
LRC(A)											
Starting current	A	166,23	197,49	245,75	182,17	212,34	222,01	278,48	292,25		
Starting current with SoftStarter	A	119,03	141,49	176,15	134,97	156,34	166,01	208,88	222,65		
SEAS FAN											
Additional Power	kW	-0,1	-0,48	-0,48	-0,1	-0,48	-0,48	-0,2	-0,58		
Additional Current	A	-1,64	-2,4	-2,4	-1,64	-2,4	-2,4	-3,28	-4,04		
HIPF FAN											
Additional Power	kW	1,62	2,08	2,08	1,62	2,08	2,08	3,24	3,7		
Additional Current	A	0,96	1,2	1,2	0,96	1,2	1,2	1,92	2,16		
LOW PRESSURE WATER PUMP											
Additional Power	kW	1,95	1,95	1,95	1,95	1,95	3,28	3,28	3,28		
Additional Current	A	3,43	3,43	3,43	3,43	3,43	6,24	6,24	6,24		
HIGH PRESSURE WATER PUMP											
Additional Power	kW	3,28	3,28	3,28	3,28	3,28	4,5	4,5	4,5		
Additional Current	A	6,24	6,24	6,24	6,24	6,24	7,62	7,62	7,62		
ANTIFREEZE ELECTRICAL HEAT (GAC)											
Additional Power	kW	6	6	6	9	9	12	12	12		
Additional Current	A	8,66	8,66	8,66	12,99	12,99	17,32	17,32	17,32		
ANTIFREEZE ELECTRICAL HEAT (GAH)											
Additional Power	kW	9	9	9	9	9	12	12	12		
Additional Current	A	12,99	12,99	12,99	12,99	12,99	17,32	17,32	17,32		
STANDARD ELECTRICAL HEATER (only GAH)											
Additional Power	kW	27	27	27	27	27	36	36	36		
Additional Current	A	38,97	38,97	38,97	38,97	38,97	51,96	51,96	51,96		
HIGH ELECTRICAL HEATER (only GAH)											
Additional Power	kW	36	36	36	36	36	48	48	48		
Additional Current	A	51,96	51,96	51,96	51,96	51,96	69,28	69,28	69,28		
SEAS	Variable airflow control with standard EC fans										
HIPF	Variable airflow control with high pressure EC fans										

1.- GENERAL CHARACTERISTICS

1.3.- COMPONENTS

The eComfort system comprises a water cooler or air/water pump combined with a series of hydraulic accessories.

STANDARD UNIT

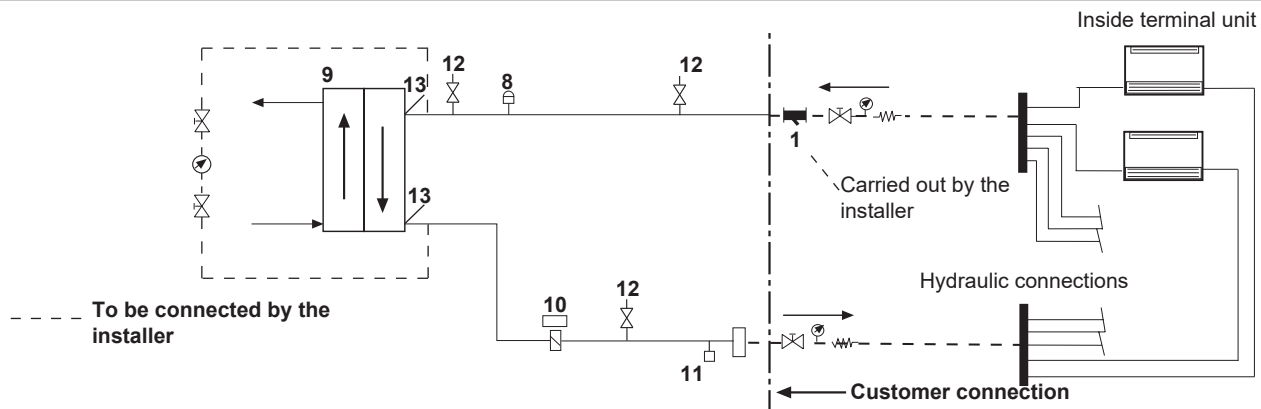

UNIT WITH WATER PUMP OPTION

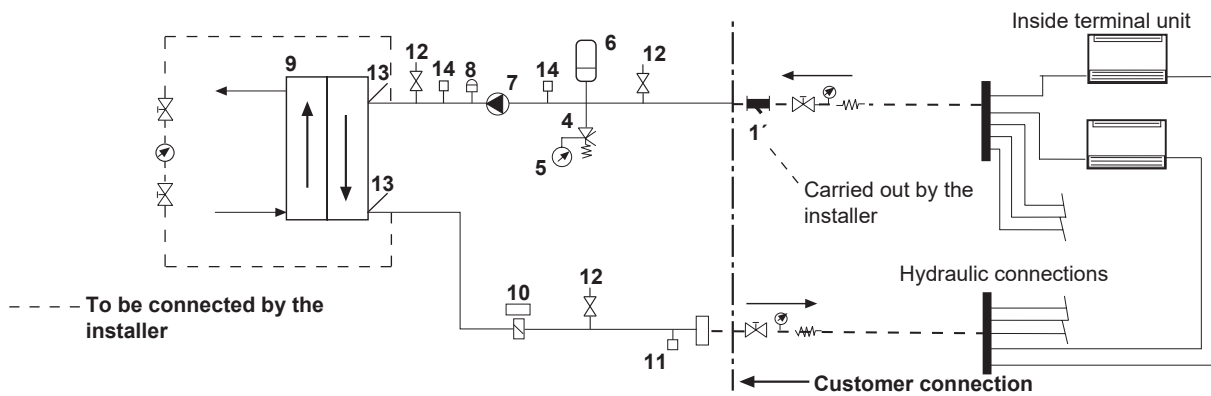

UNIT WITH WATER TANK OPTION

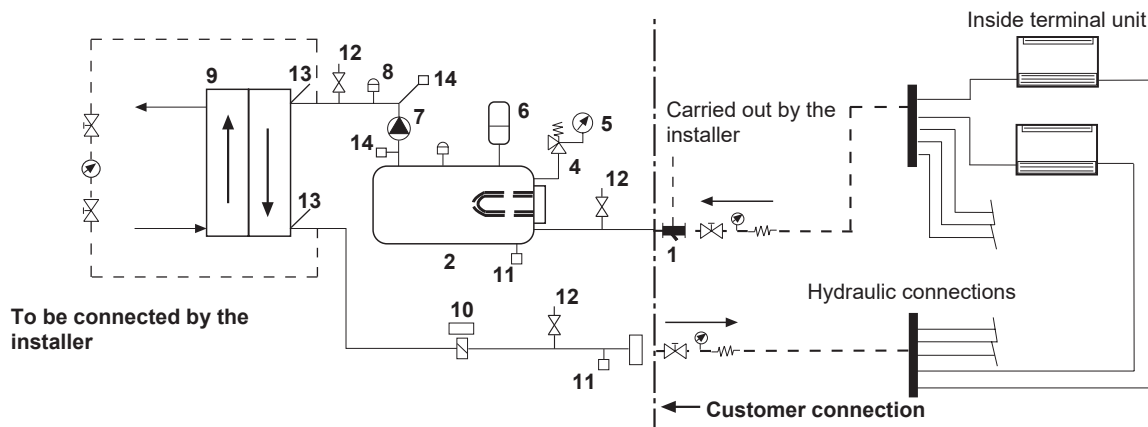

COMPONENTS:

STANDARD VERSION	UNIT WITH WATER PUMP OPTION	UNIT WITH WATER TANK OPTION
8, 9, 10, 11, 12, 13	4, 5, 6, 7, 8, 9, 10, 11, 12, 13, 14	2, 3, 4, 5, 6, 7, 8, 9, 10, 11, 12, 13, 14

1	Water filter (additional option, supplied loose)	6	Expansion vessel	11	Drain valve
2	Water tank	7	Water pump	12	Pressure tap
3	Water tank heater	8	Air purge valve	13	Water temperature sensor
4	Safety valve	9	Plate exchanger	14	Pressure transducer (when variable water flow option is selected)
5	Pressure gauge	10	Flow switch		

The use of a water filter in the water circuit upstream of the heat exchanger is mandatory. These filters must remove all particles with a diameter greater than 1 mm, and must be positioned within 1 meter of the inlet of the exchanger. They may be supplied as an option by the manufacturer.

1.- GENERAL CHARACTERISTICS

1.4.- OPERATING LIMITS

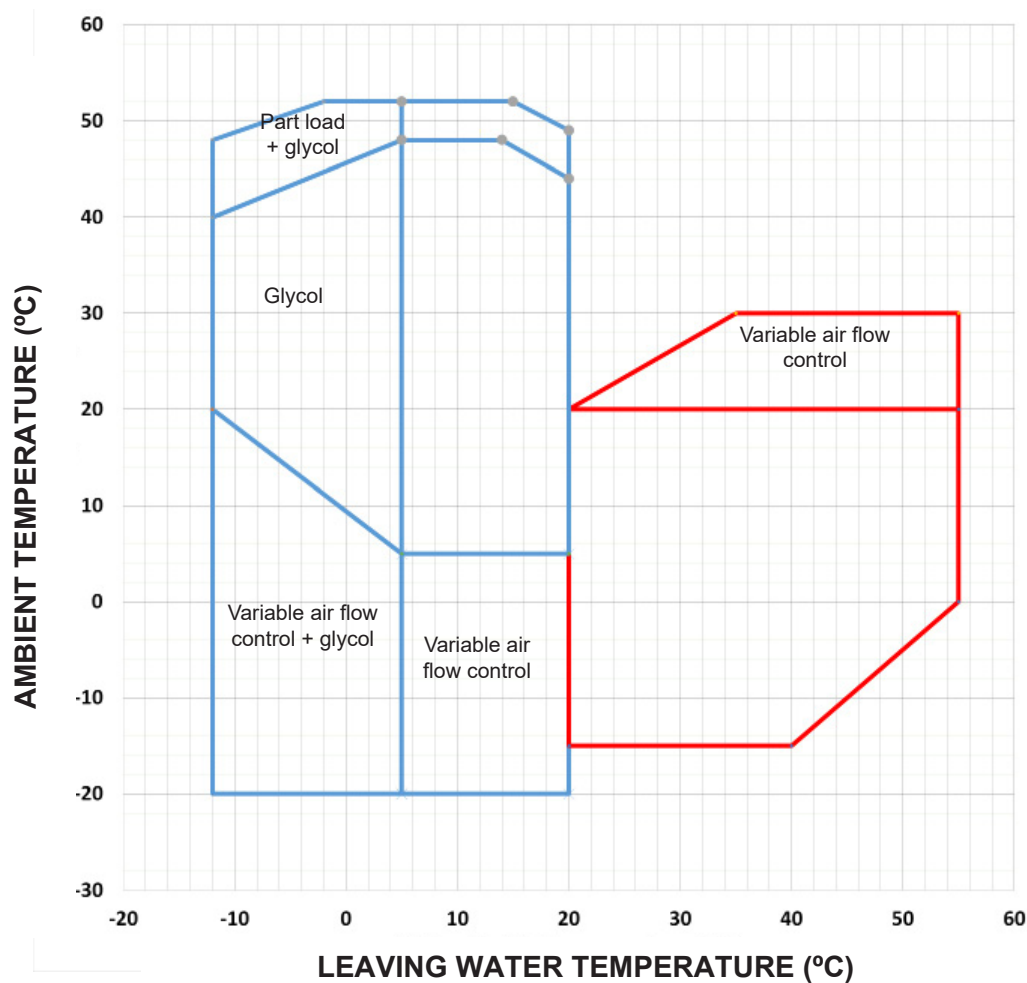

UNITS WITH LOW WATER TEMPERATURE KIT (OPTION)

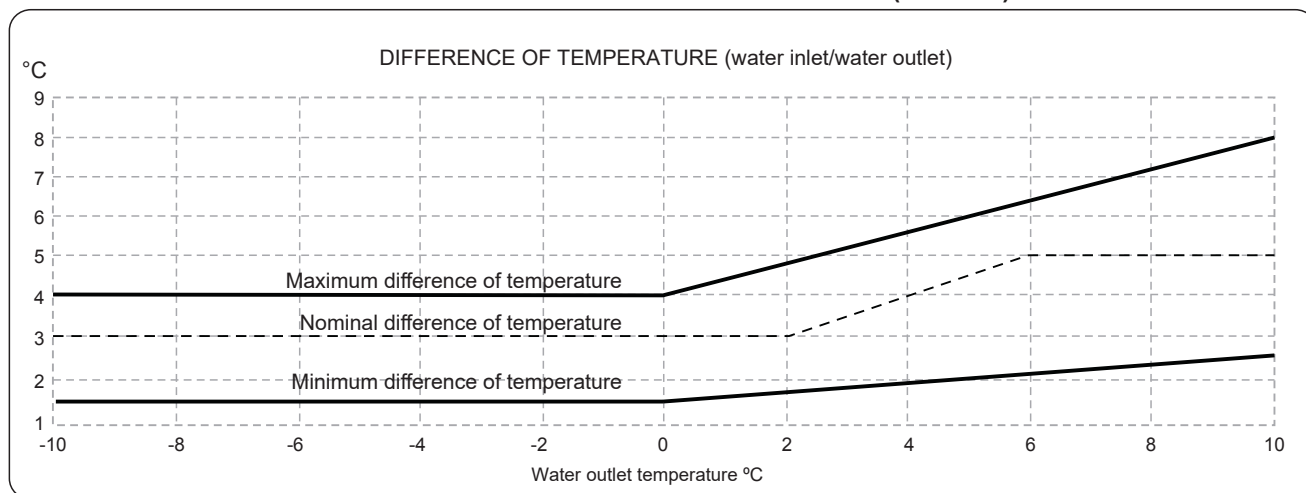

1.- GENERAL CHARACTERISTICS

1.5.- HYDRAULIC SYSTEM DATA

WATER FLOW AND AVAILABLE STATIC PRESSURE OF WATER PUMP

**GAC/GAH
020S - 025S**

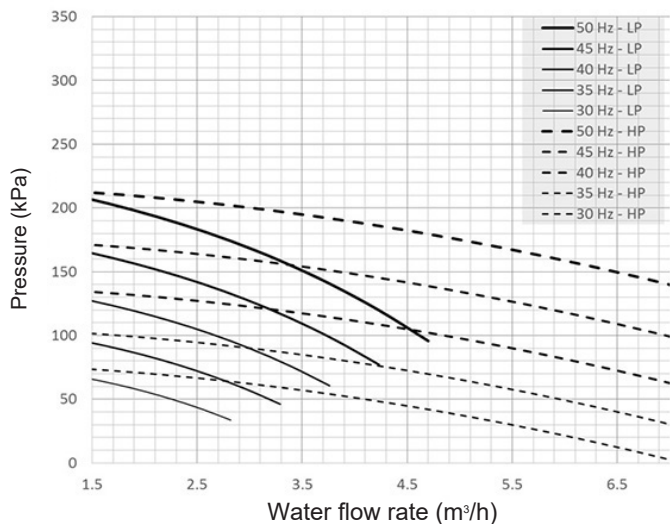

**GAC/GAH
030S - 035S**

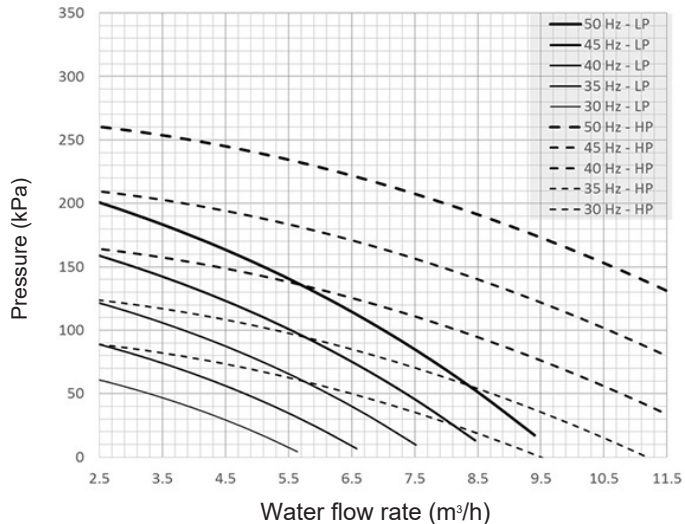

**GAC/GAH
040S - 045S**

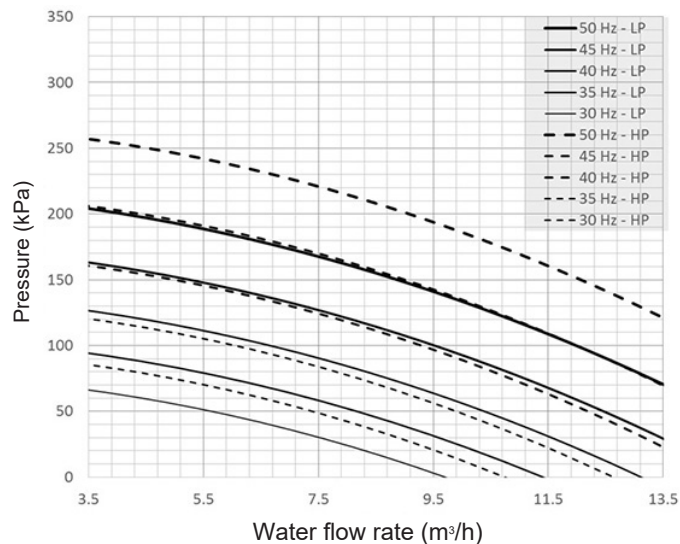

**GAC/GAH
055S - 060S**

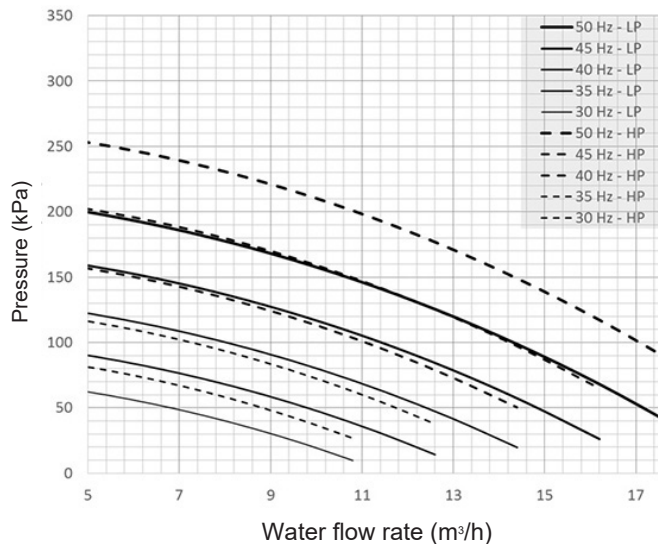

1.- GENERAL CHARACTERISTICS

1.5.- HYDRAULIC SYSTEM DATA

WATER FLOW AND AVAILABLE STATIC PRESSURE OF WATER PUMP

**GAC/GAH
070S / 080S**

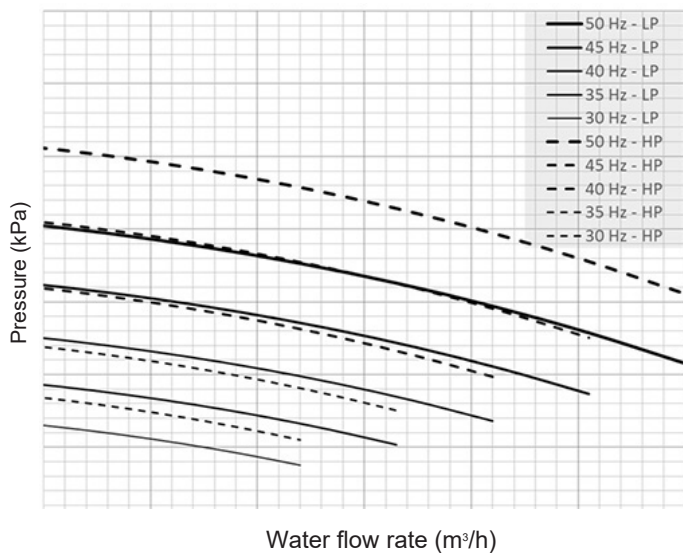

**GAC/GAH
090S**

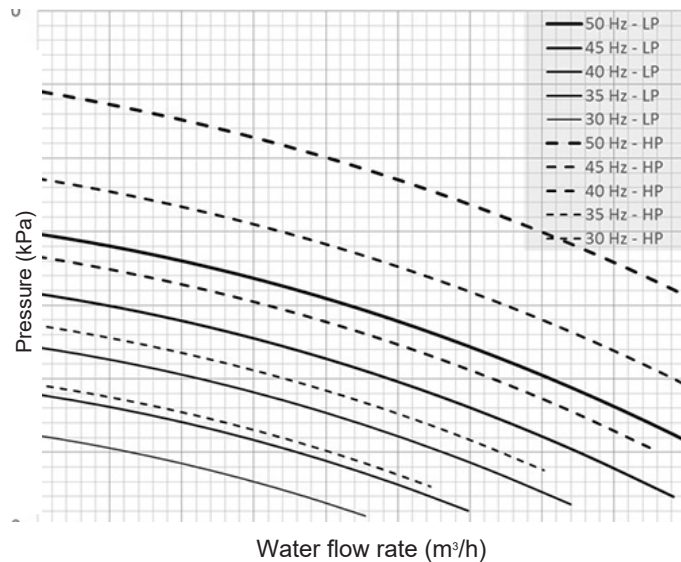

**GAC/GAH
110S / 125S**

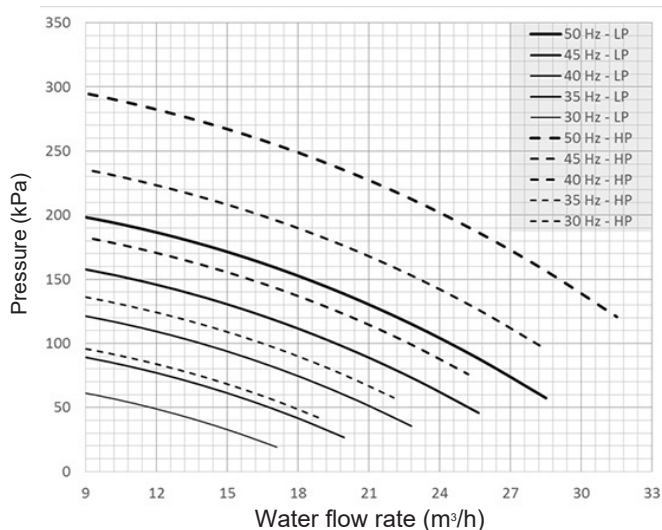

**GAC/GAH
110D / 125D**

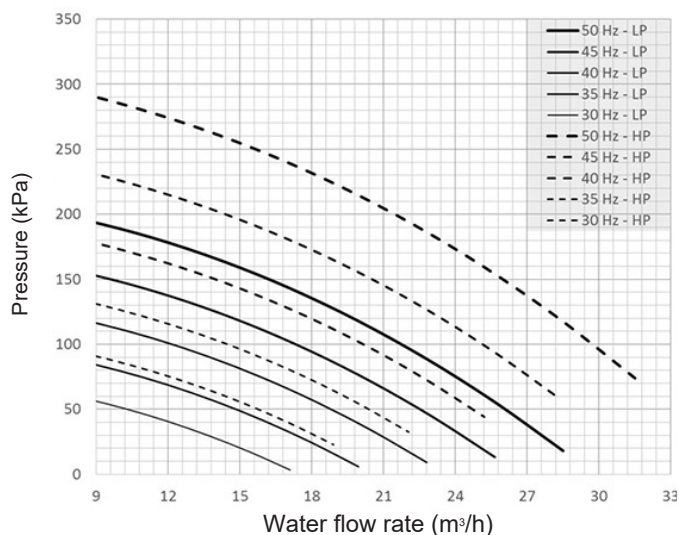

1.- GENERAL CHARACTERISTICS

1.5.- HYDRAULIC SYSTEM DATA

WATER FLOW AND AVAILABLE STATIC PRESSURE OF WATER PUMP

**GAC/GAH
140D / 160D**

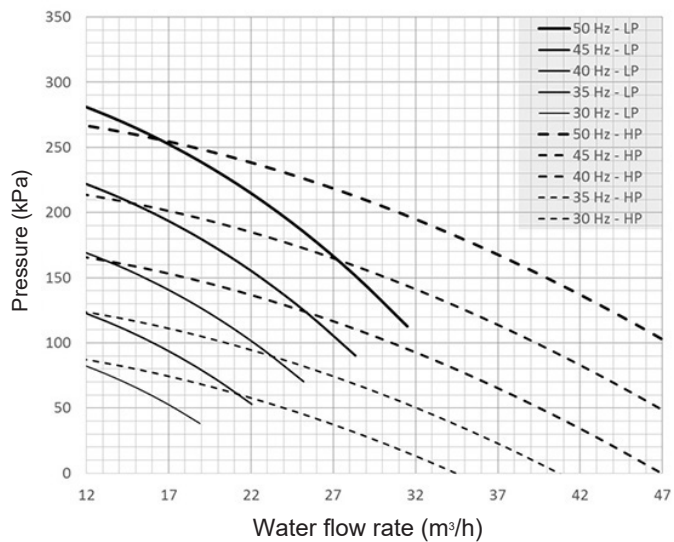

**GAC/GAH
185D**

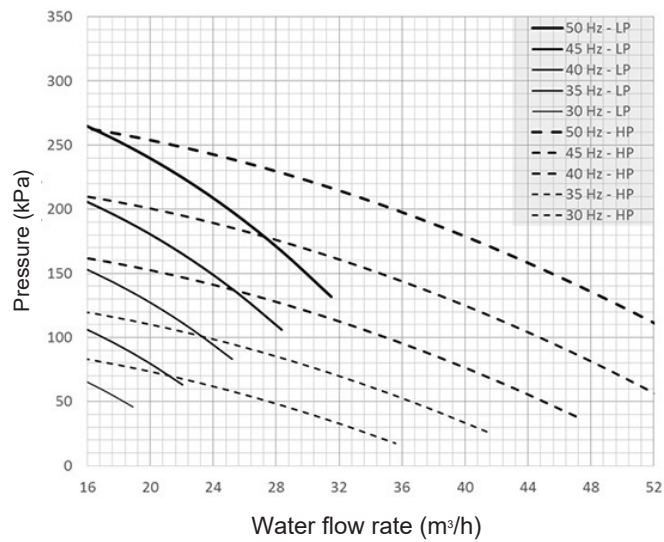

1.- GENERAL CHARACTERISTICS

1.6- PRESSURE DROP IN THE WATER SYSTEM

Pressure drop of the unit without water filter

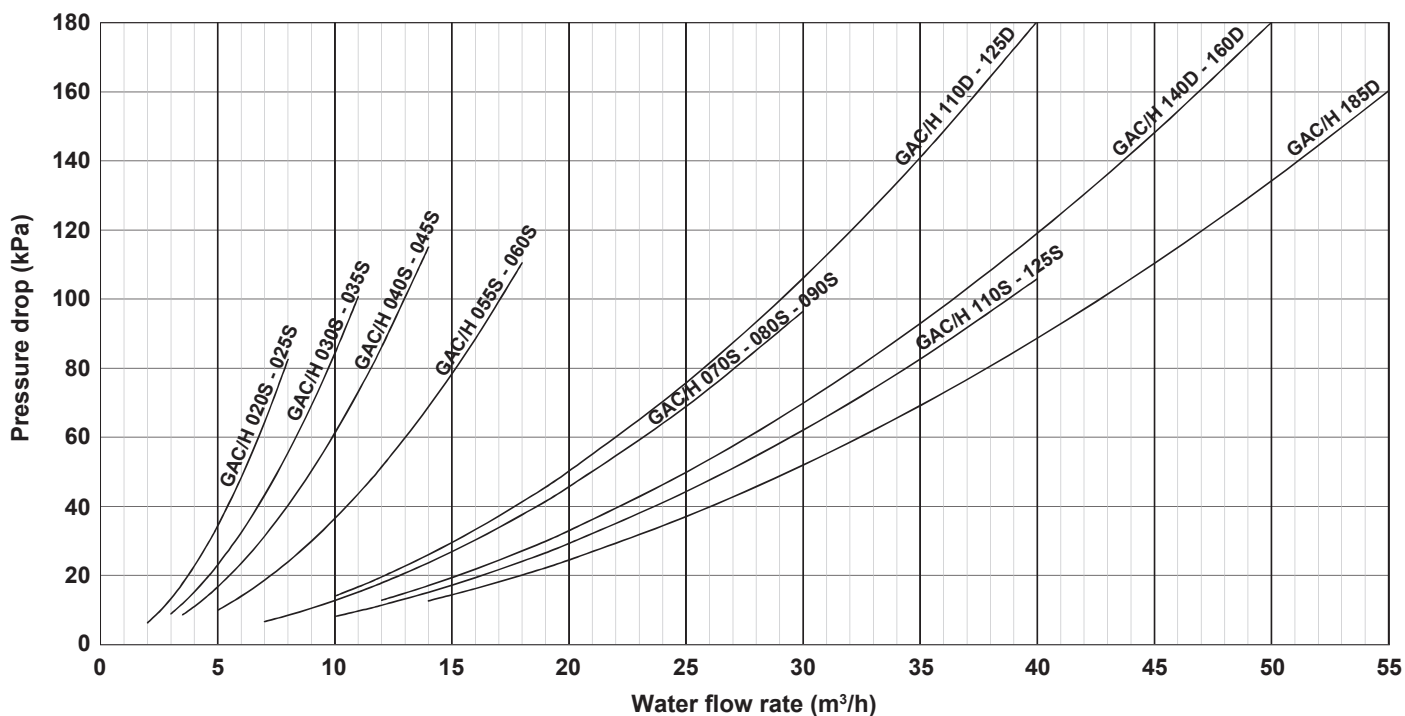

Pressure drop for option water filter

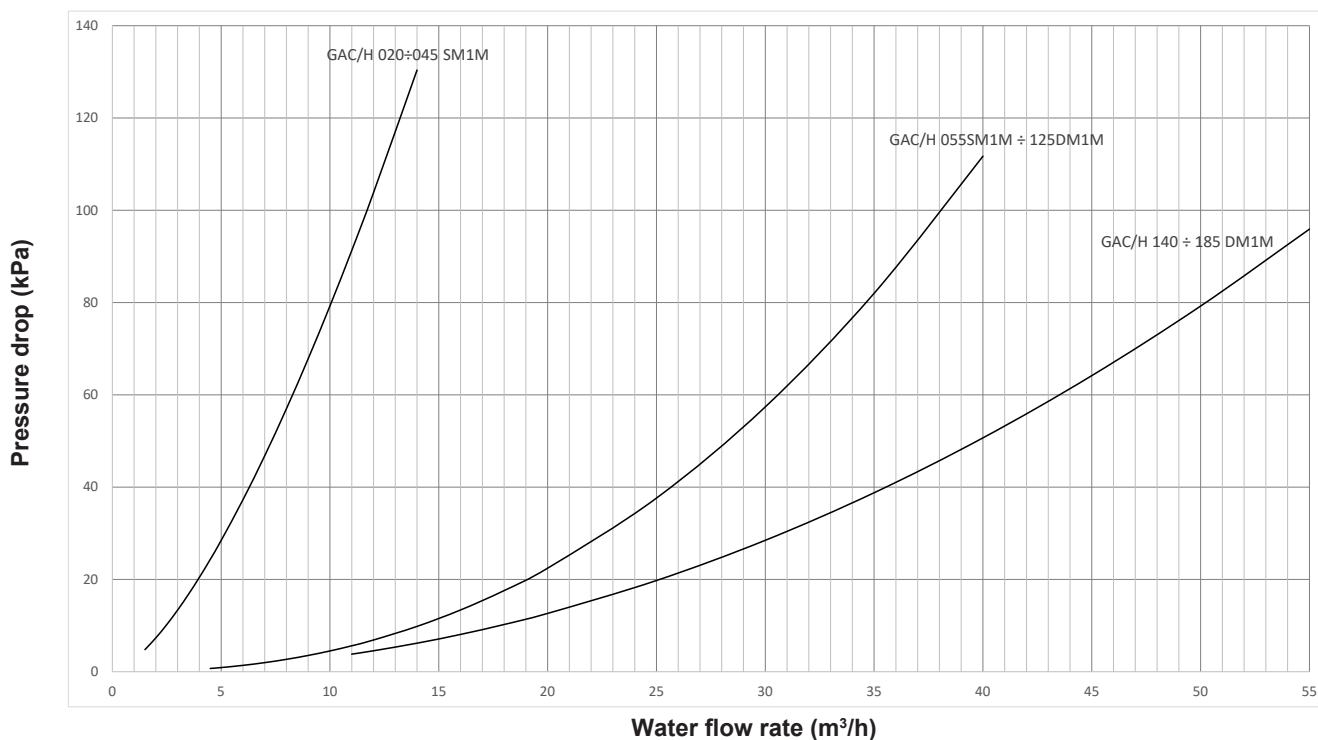

1.- GENERAL CHARACTERISTICS

1.7.- WATER FLOW

UNIT MODEL	WATER FLOW RATE (m ³ /h)			WATER CONTENT (dm ³)	
	MINIMUM	NOMINAL	MAXIMUM	Unit without buffer tank	Buffer tank
GAC 020S	1.7	3.5	5.8	4.0	100
GAC 025S	2.1	4.2	7.0	4.0	100
GAC 030S	2.7	5.5	9.1	4.6	100
GAC 035S	3.2	6.4	10.6	4.6	100
GAC 040S	3.5	6.9	11.5	5.2	100
GAC 045S	3.9	7.8	13.0	5.2	100
GAC 055S	4.7	9.4	15.7	6.0	175
GAC 060S	5.3	10.5	17.5	6.0	175
GAC 070S	6.0	12.0	19.9	10.2	175
GAC 080S	7.1	14.2	23.7	10.2	175
GAC 090S	7.9	15.7	26.1	11.3	175
GAC 110S	9.2	18.4	30.6	14.1	175
GAC 125S	10.5	21.0	35.0	14.1	175
GAC 110D	9.1	18.2	30.2	13.0	250
GAC 125D	10.6	21.2	35.3	13.0	250
GAC 140D	11.9	23.9	39.7	24.3	400
GAC 160D	13.9	27.9	46.4	24.3	400
GAC 185D	15.9	31.8	53.0	27.1	400
GAH 020S	1.7	3.4	5.7	4.0	100
GAH 025S	2.1	4.2	7.0	4.0	100
GAH 030S	2.7	5.3	8.9	4.6	100
GAH 035S	3.1	6.3	10.4	4.6	100
GAH 040S	3.4	6.8	11.3	5.2	100
GAH 045S	3.9	7.7	12.8	5.2	100
GAH 055S	4.7	9.3	15.5	6.0	175
GAH 060S	5.2	10.3	17.2	6.0	175
GAH 070S	5.9	11.8	19.6	10.2	175
GAH 080S	7.0	14.0	23.3	10.2	175
GAH 090S	7.8	15.6	25.9	11.3	250
GAH 110S	9.1	18.2	30.2	14.1	250
GAH 125S	10.4	20.7	34.5	14.1	250
GAH 110D	9.0	18.0	30.0	13.0	250
GAH 125D	10.4	20.8	34.7	13.0	250
GAH 140D	11.7	23.5	39.1	24.3	400
GAH 160D	13.7	27.4	45.6	24.3	400
GAH 185D	15.6	31.2	52.0	27.1	400

1.- GENERAL CHARACTERISTICS

1.8.- PIPING DRAWINGS COOLING ONLY UNITS

GAC 020S-025S-030S-035S-040S-045S

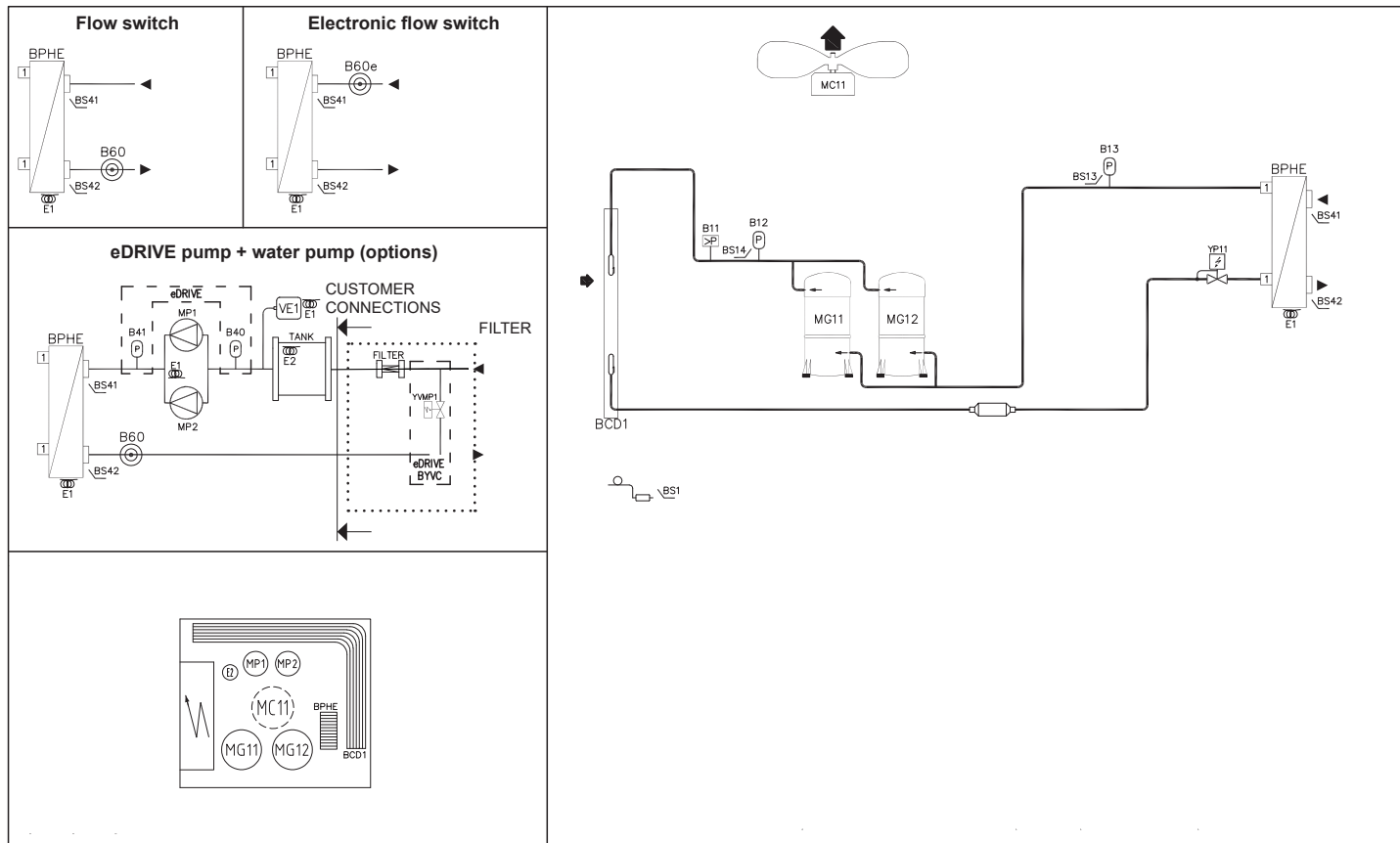

GAC 055S-060S-070S-080S

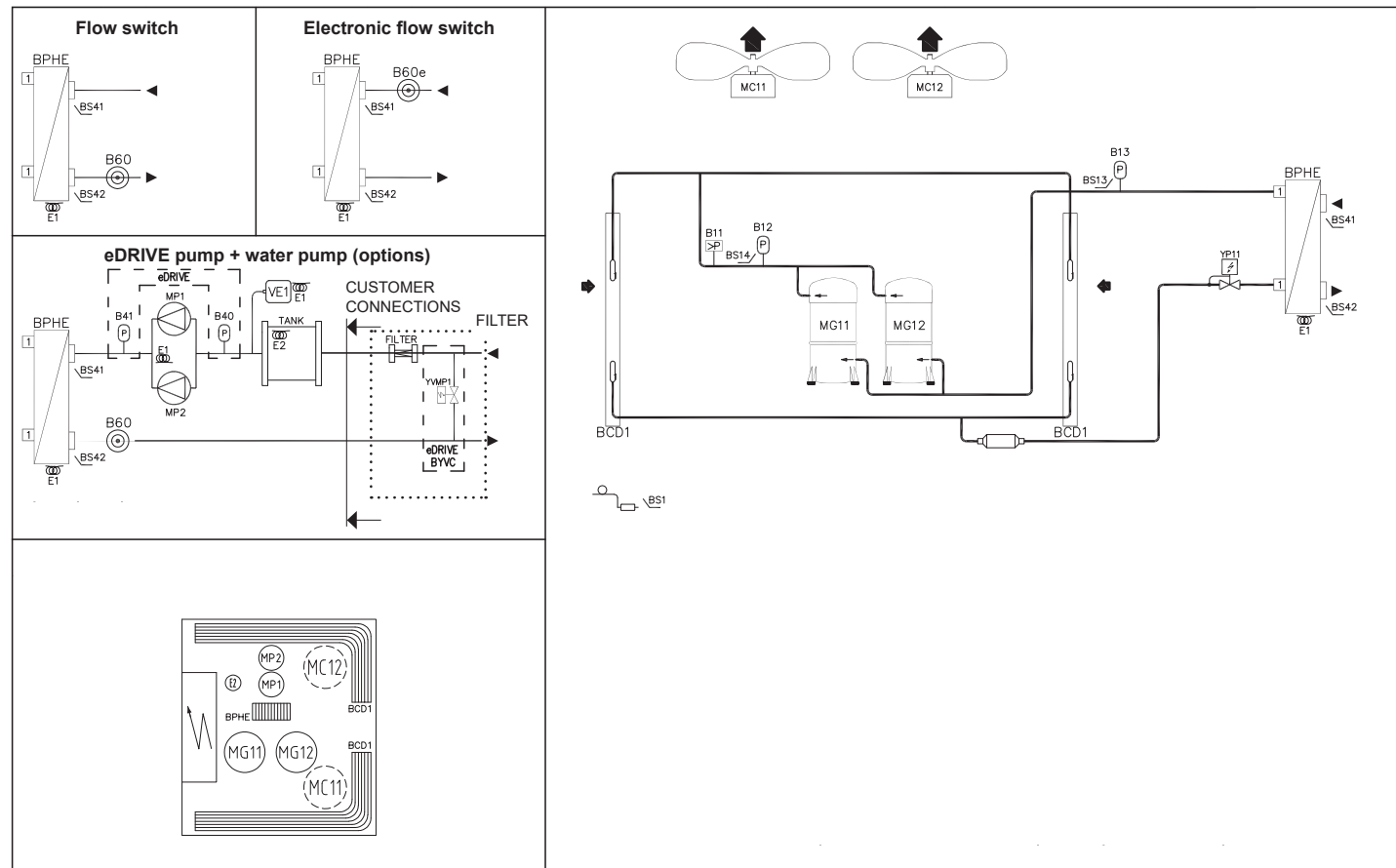

1.- GENERAL CHARACTERISTICS

1.8.- PIPING DRAWINGS
COOLING ONLY UNITS

GAC 090S-110S-125S

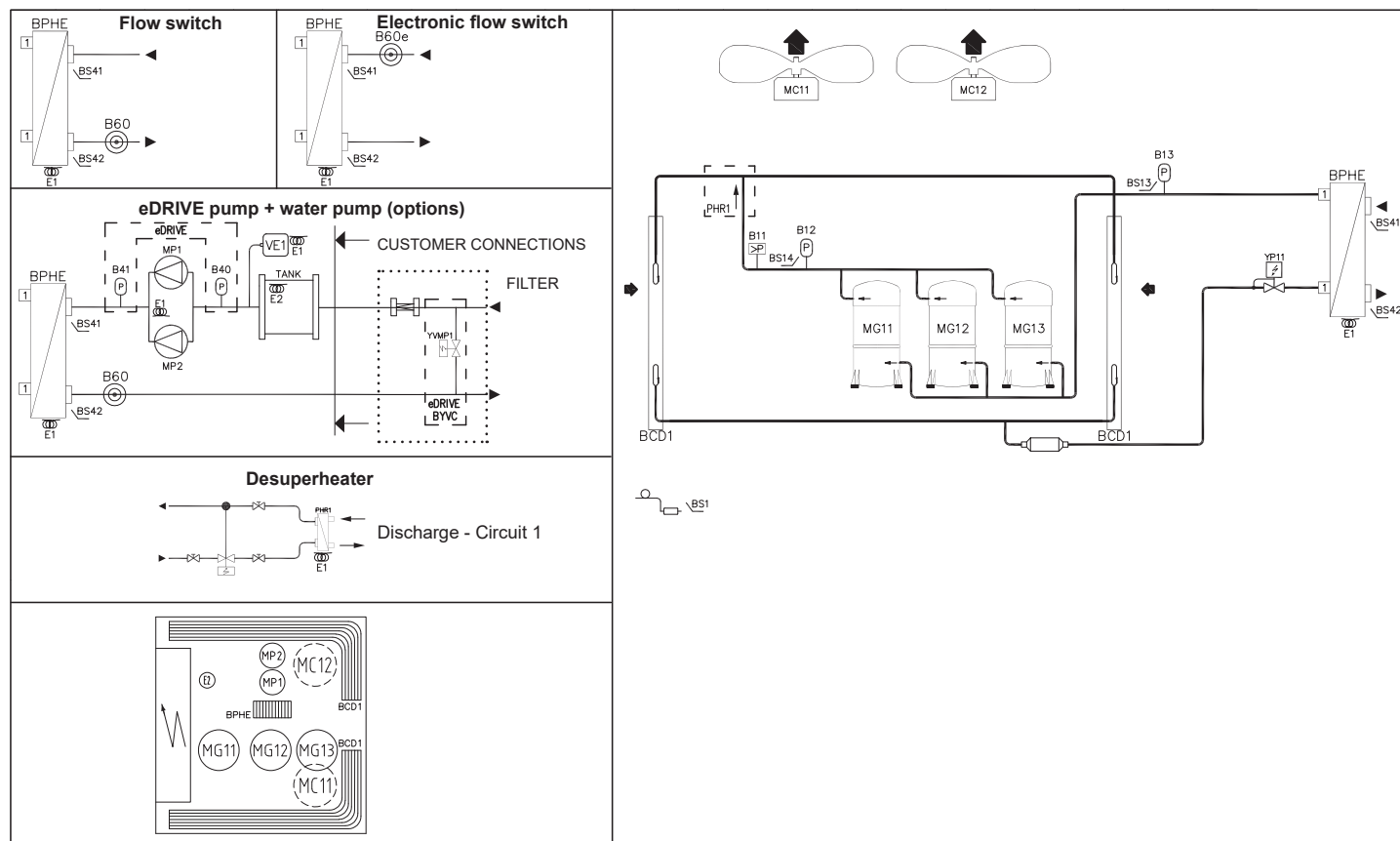

GAC 110D-125D

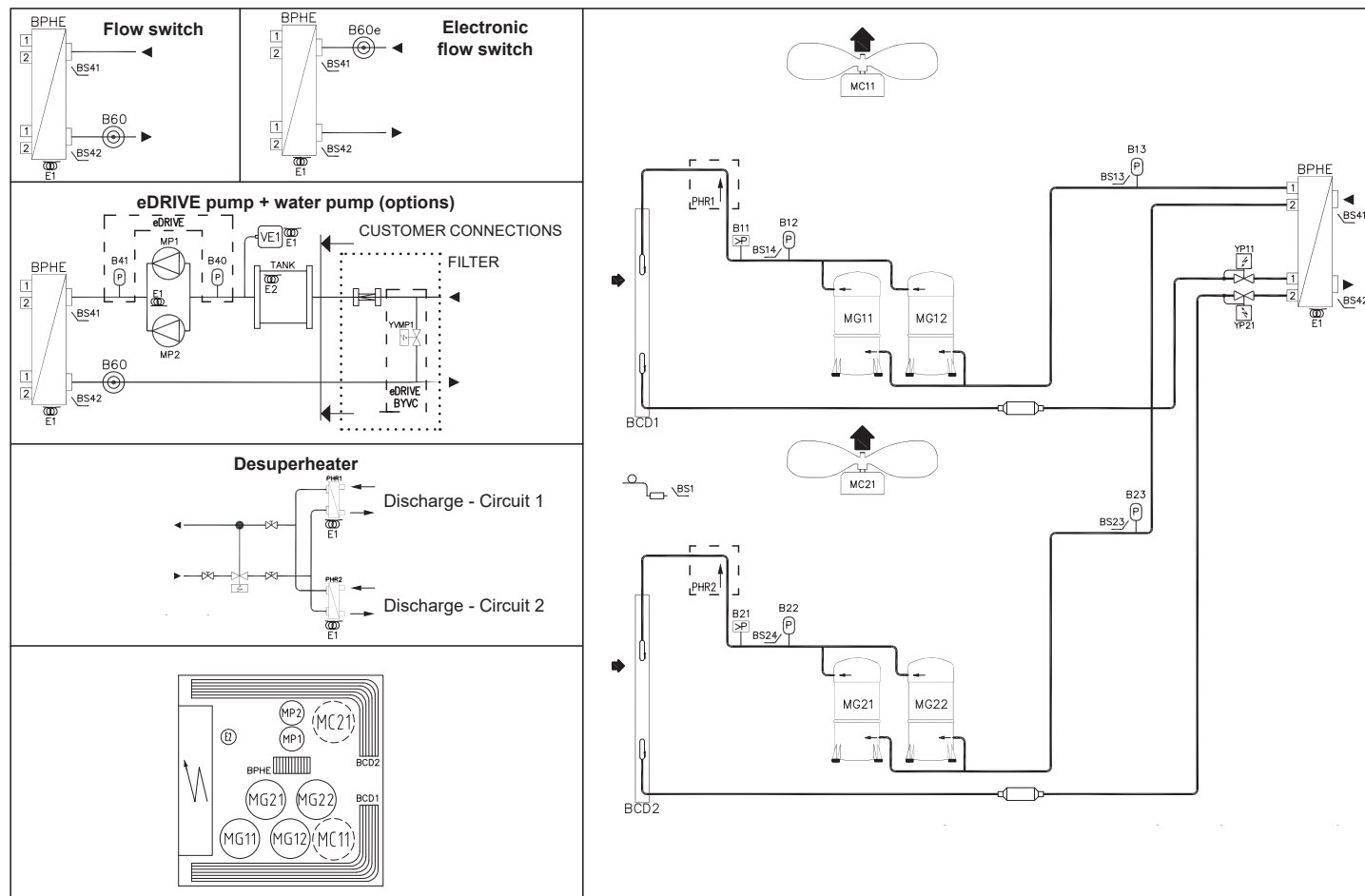

1.- GENERAL CHARACTERISTICS

1.8.- PIPING DRAWINGS COOLING ONLY UNITS

GAC 140D

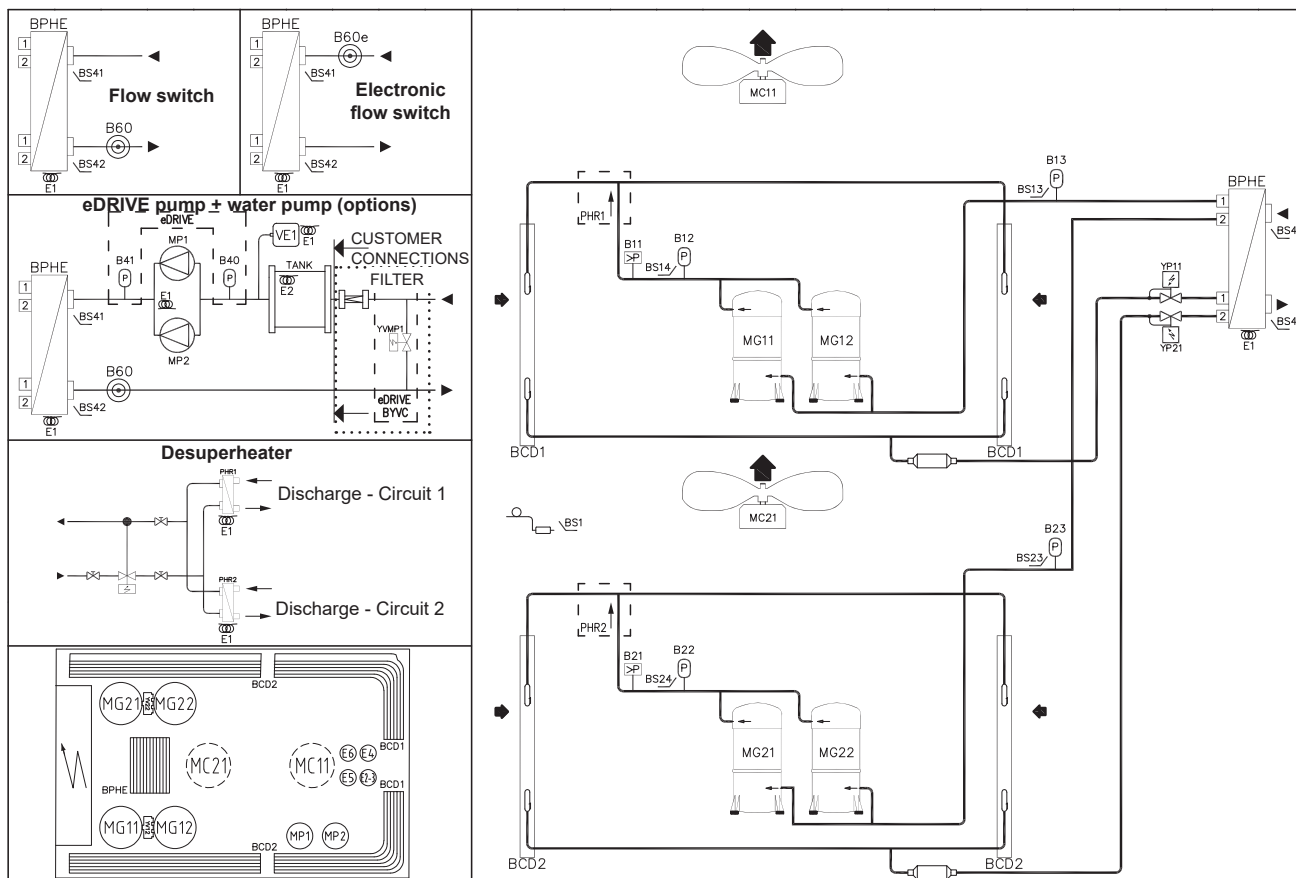

GAC 160D

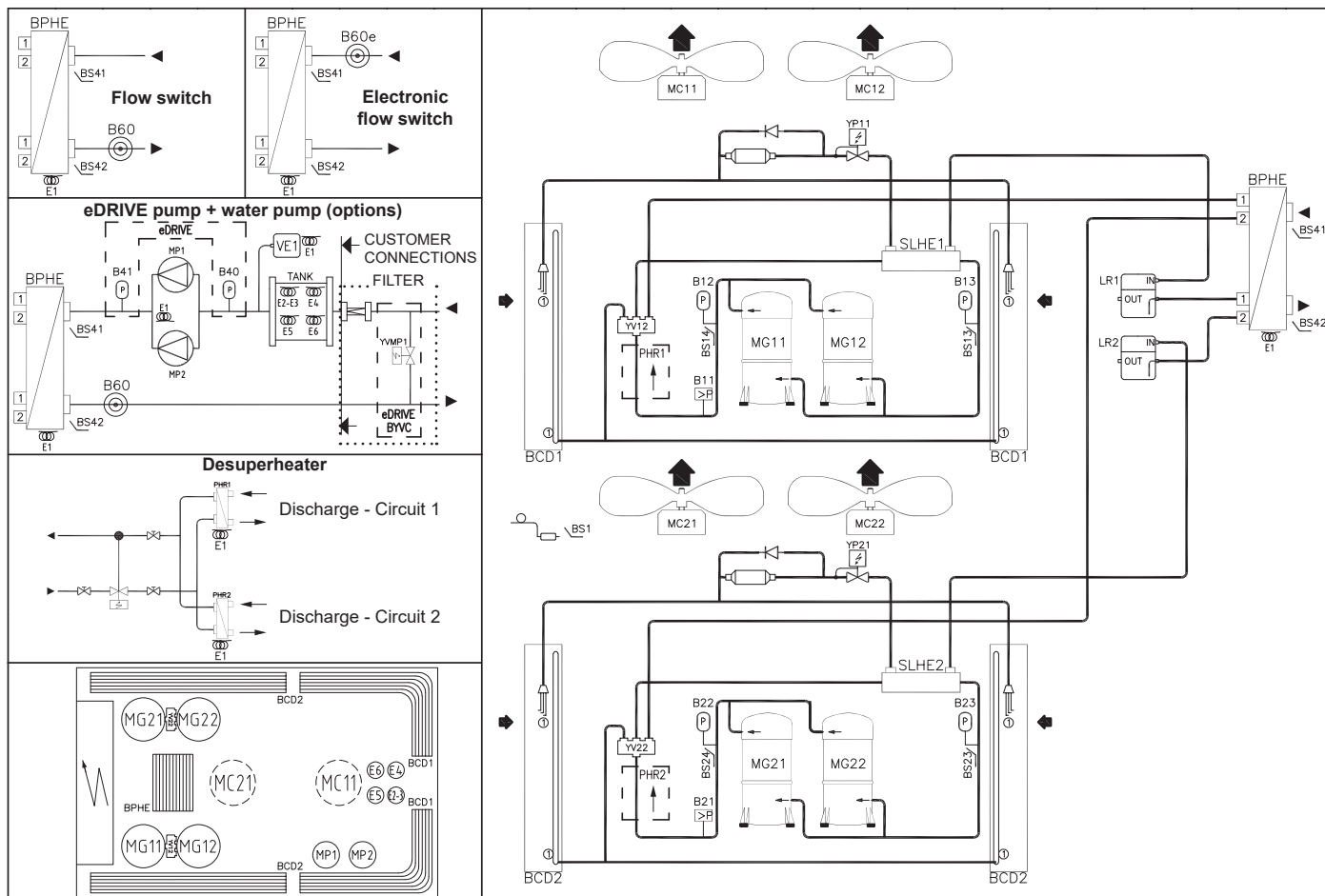

1.- GENERAL CHARACTERISTICS

1.8.- PIPING DRAWINGS COOLING ONLY UNITS

GAC 185D

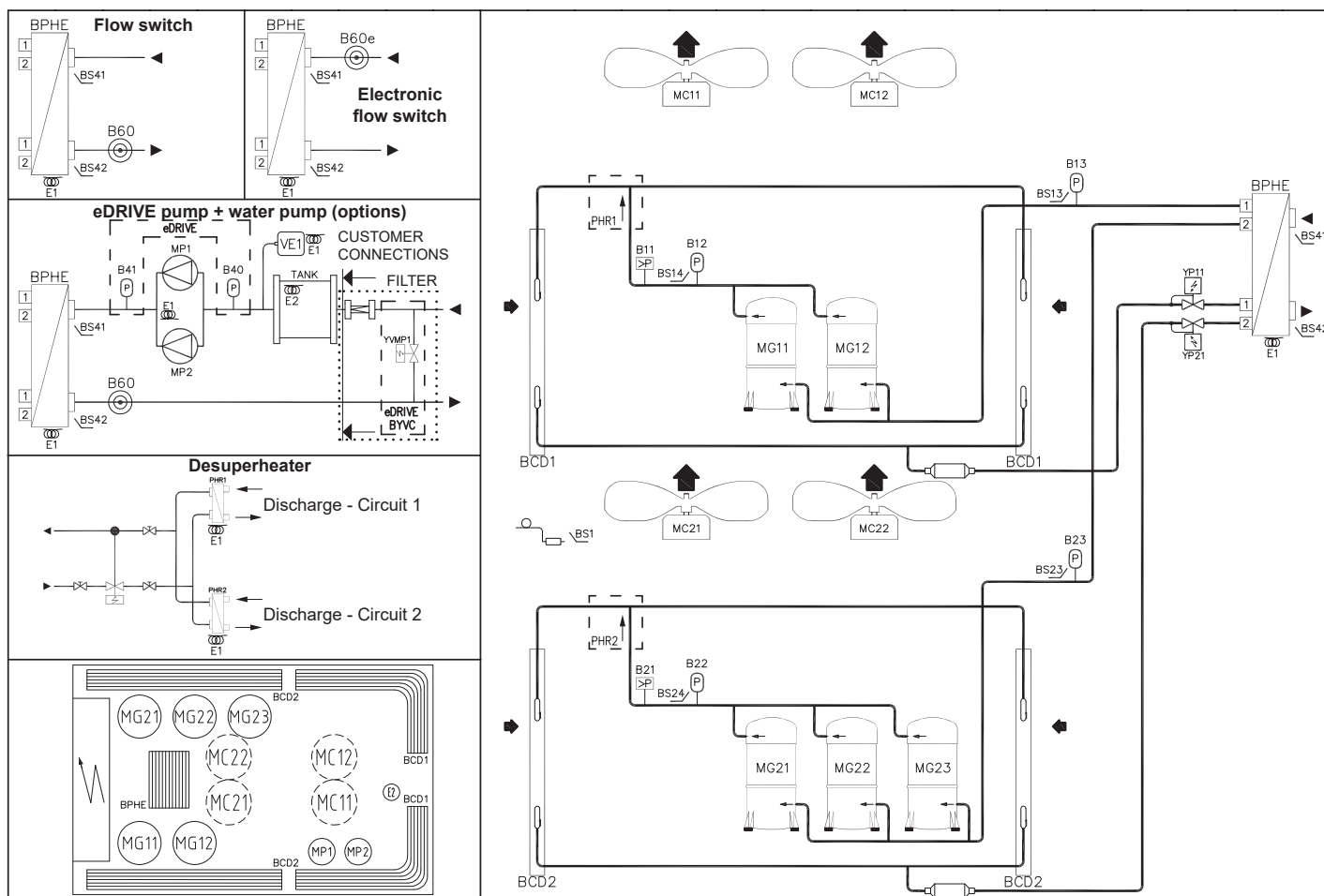

LEGEND

B11	High pressure pressostat 1
B12	High pressure transducer 1
B13	Low pressure transducer 1
B21	High pressure pressostat 2
B22	High pressure transducer 2
B23	Low pressure transducer 2
B40	Inlet water pressure
B41	Outlet water pressure
B60	Water flow switch
B60e	Electronic water flow switch
BCD	Condenser
BPHE	Evaporator (plate heat exchanger)
BS1	Outdoor temperature
BS13	Suction temperature 1
BS14	Discharge temperature 1
BS23	Suction temperature 2
BS24	Discharge temperature 2

LEGEND

BS41	Inlet water temperature
BS42	Outlet water temperature
E1	Evaporator antifreeze heater
E2	Antifreeze heater
E3-4-5-6	Electrical heater
LR	Liquid receiver
MC	Fan
MG	Scroll compressor
MP	Water Pump
PHR 1-2	Partial Heat Recovery
SLHE	Suction liquid heat exchanger
VE1	Expansion vessel
YP11	Electronic expansion valve - Circuit 1
YP21	Electronic expansion valve - Circuit 2
YV12-22	4 way reversing valve
YVMP1	By-pass valve

1.- GENERAL CHARACTERISTICS

1.8.- PIPING DRAWINGS HEAT PUMP UNITS

GAH 020S-025S-030S-035S-040S-045S

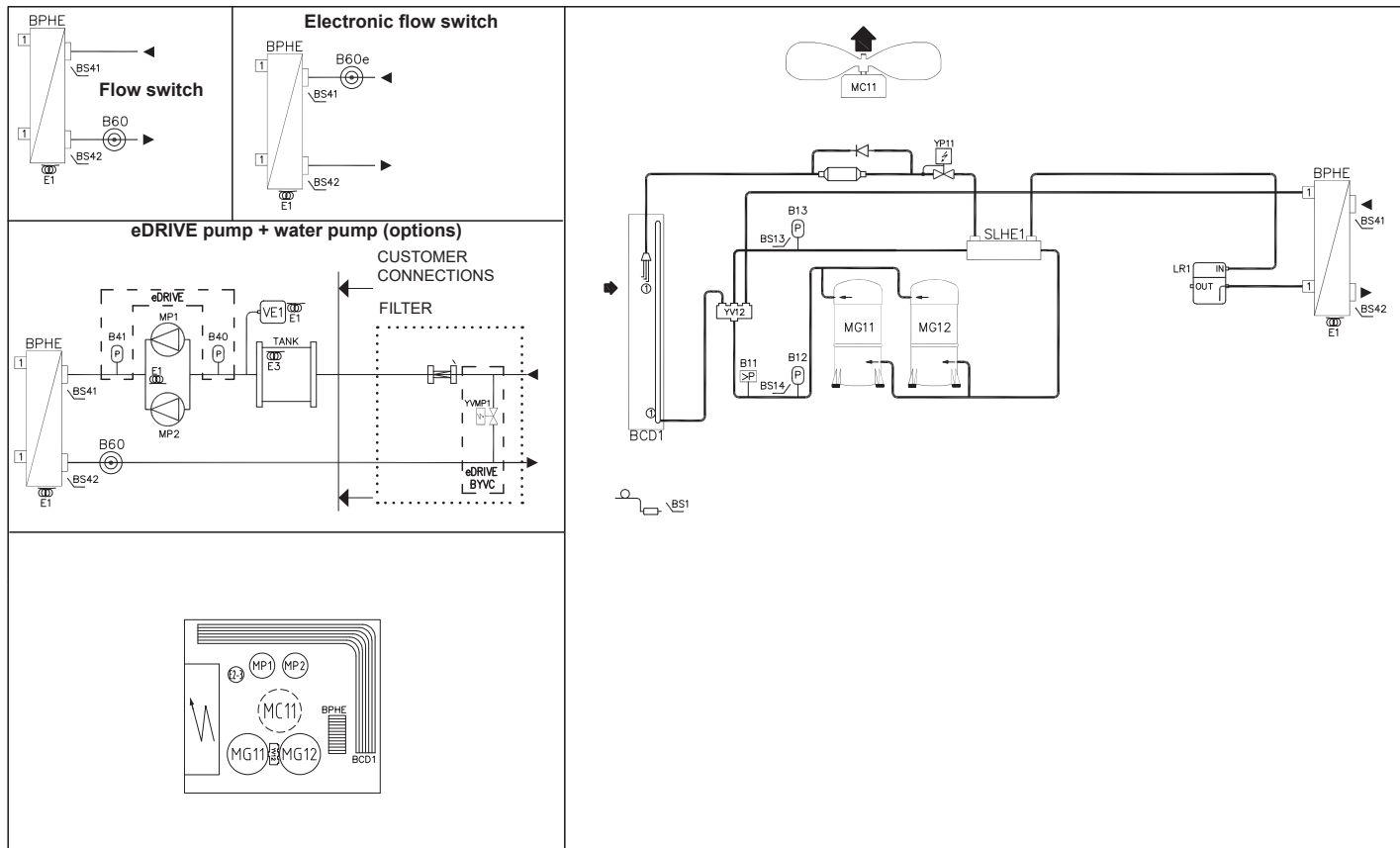

GAH 055S-060S-070S-080S

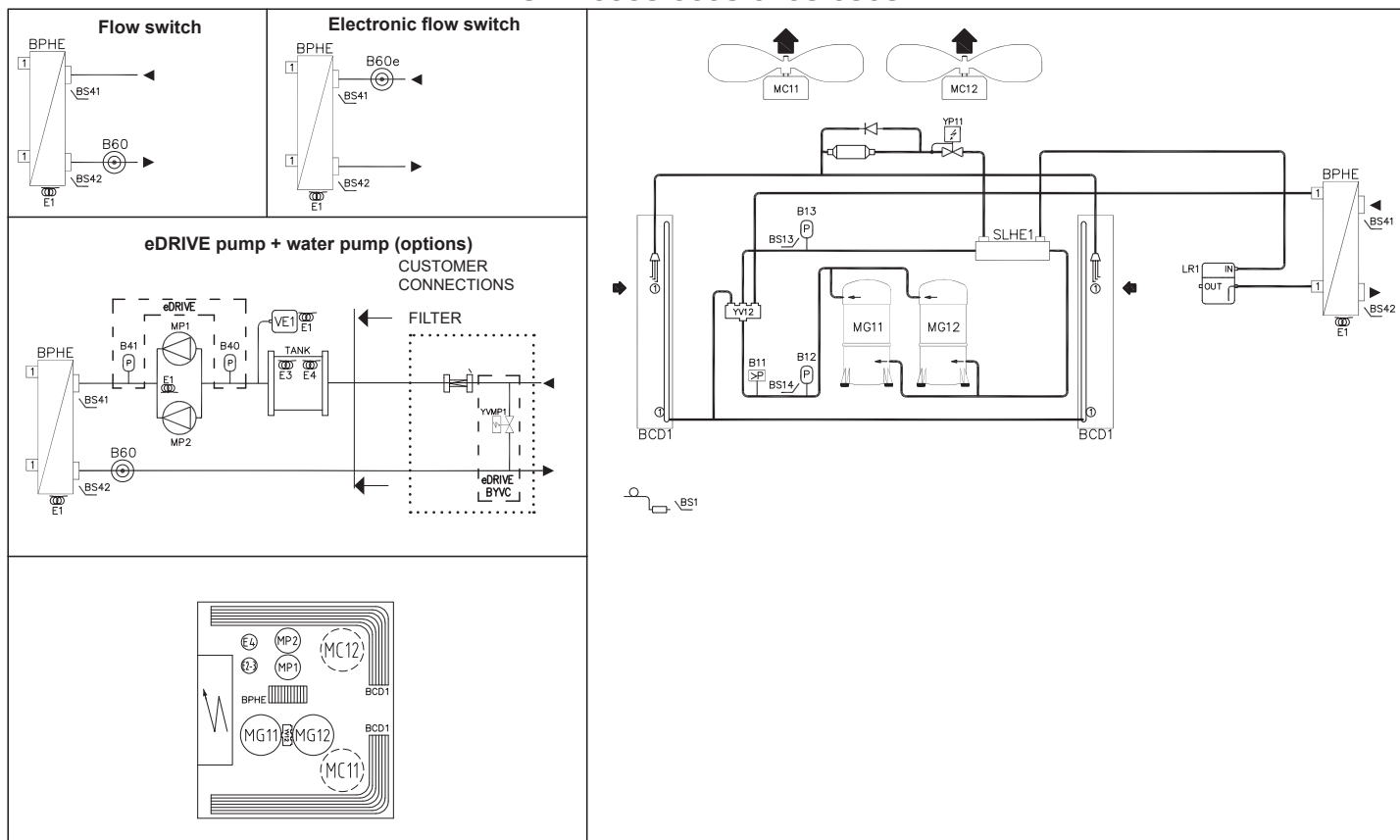

1.- GENERAL CHARACTERISTICS

**1.8.- PIPING DRAWINGS
HEAT PUMP UNITS**

GAH 090S-110S-125S

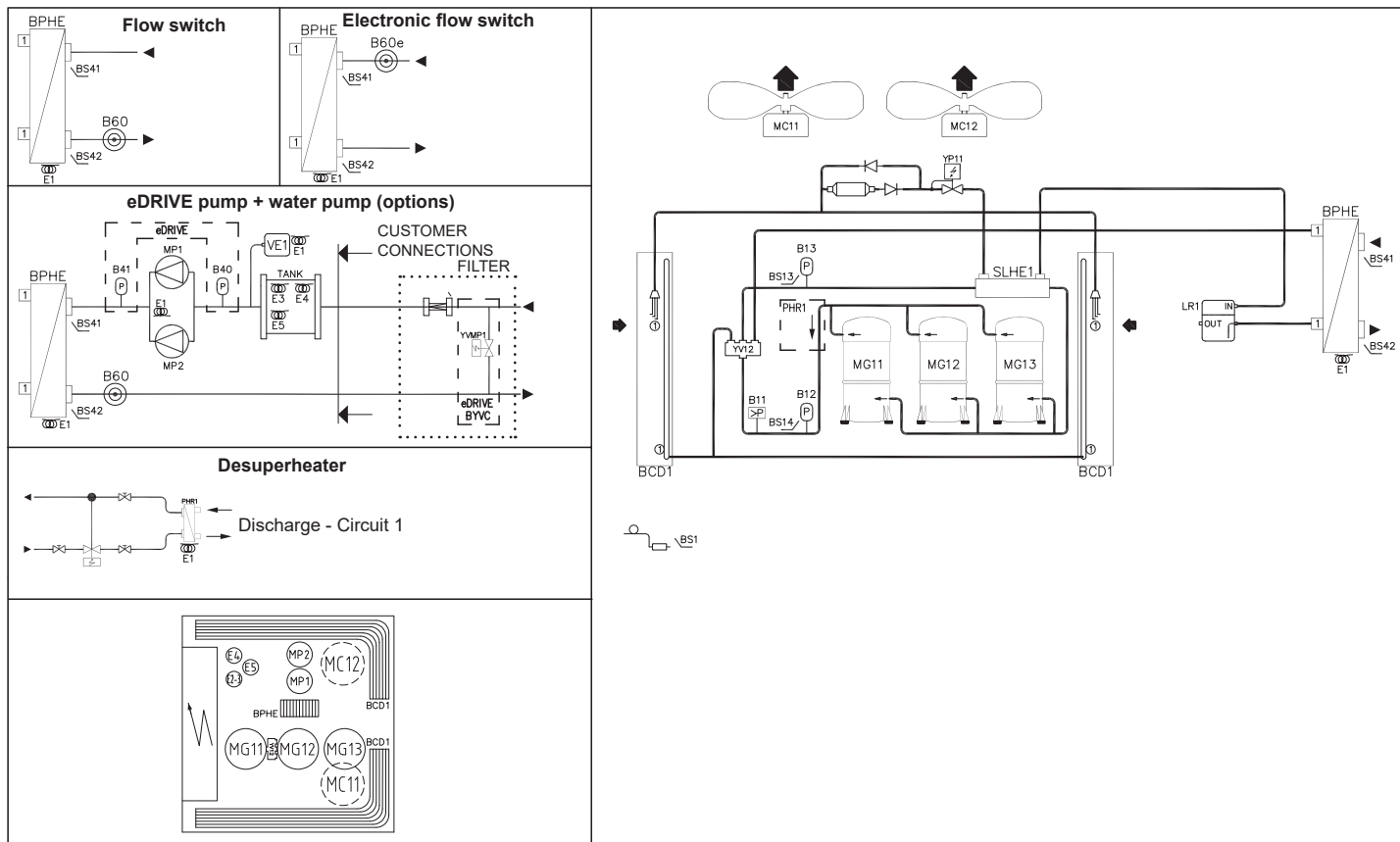

GAH 110D-125D

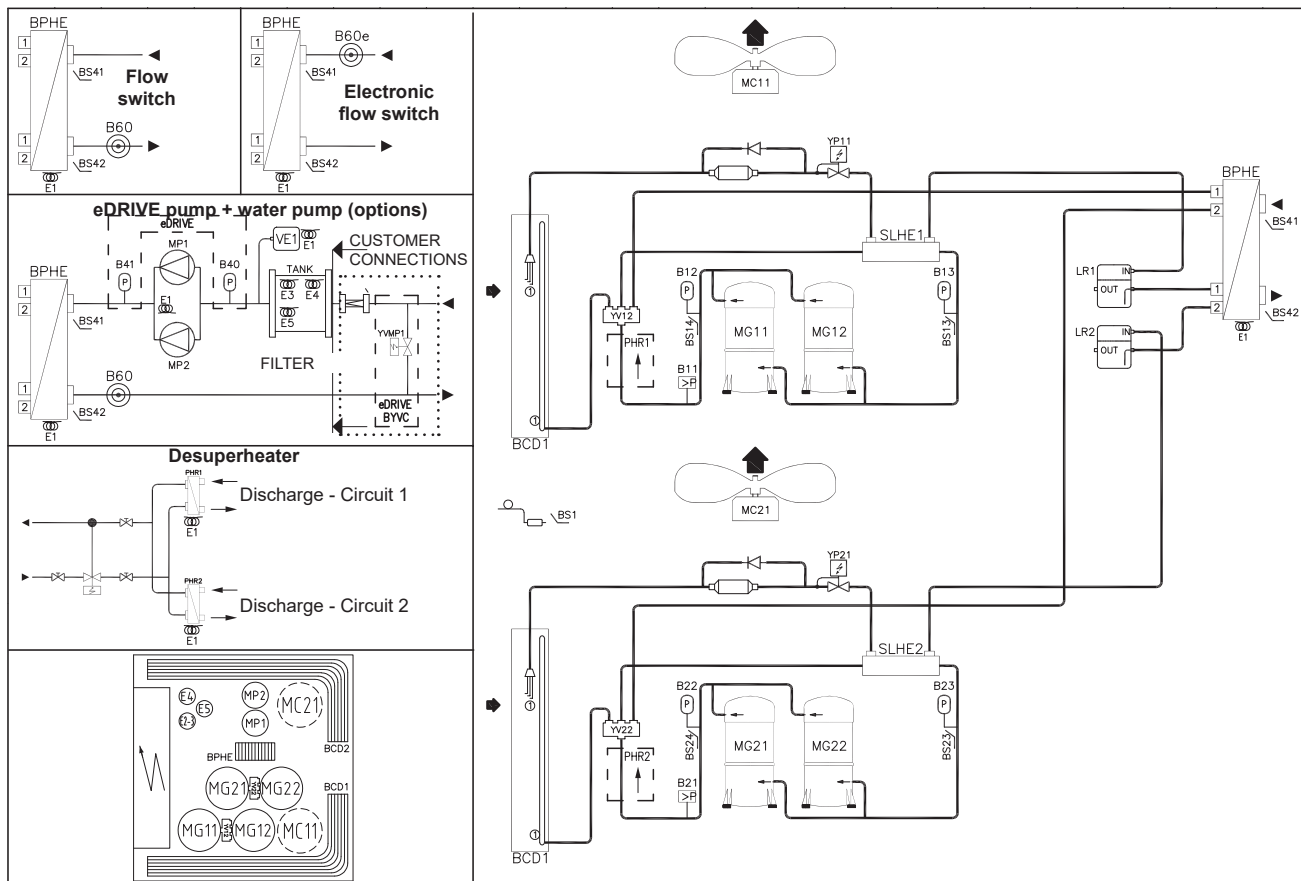

1.- GENERAL CHARACTERISTICS

1.8.- PIPING DRAWINGS HEAT PUMP UNITS

GAH 140D

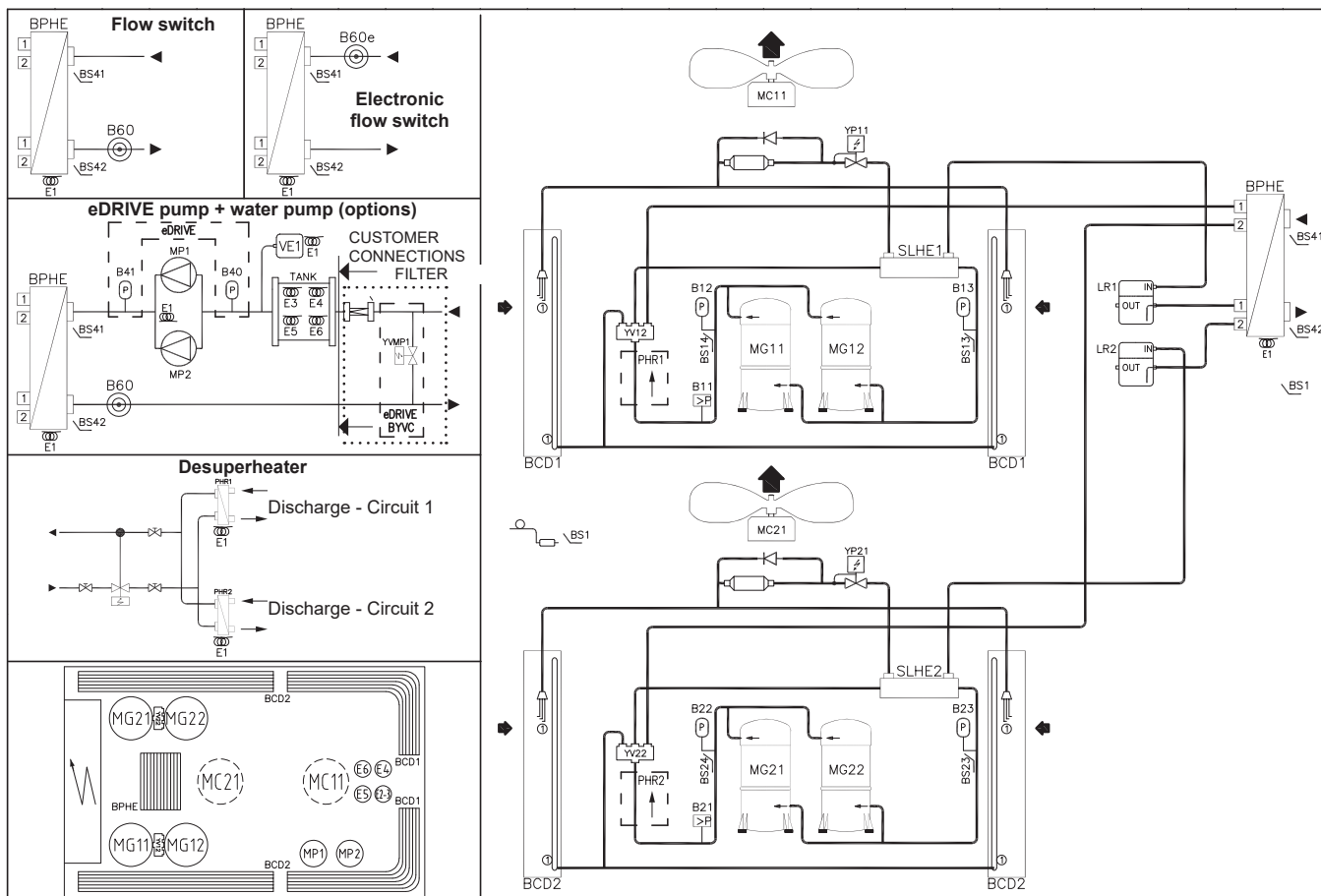

GAH 160D

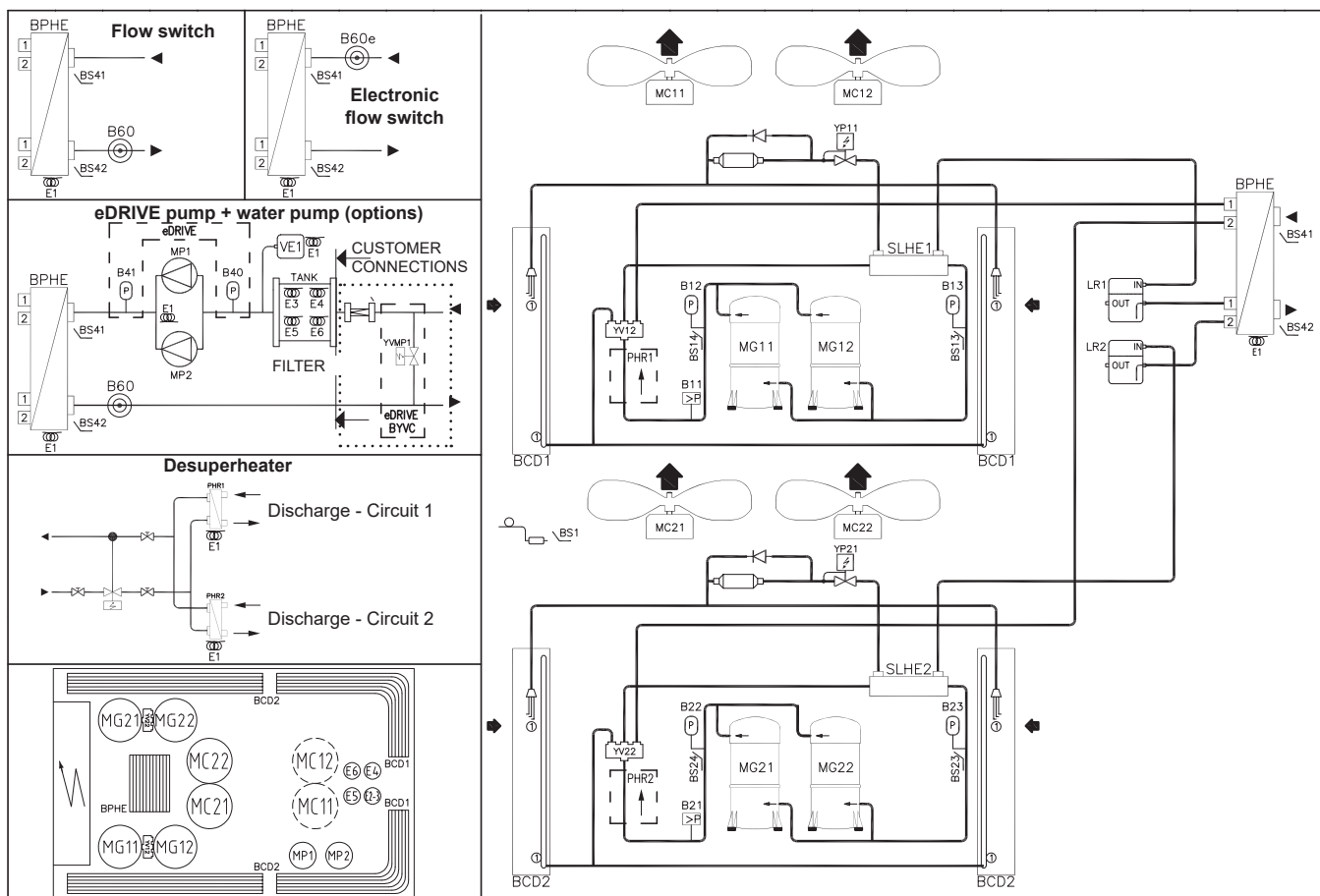

1.- GENERAL CHARACTERISTICS

1.8.- PIPING DRAWINGS HEAT PUMP UNITS

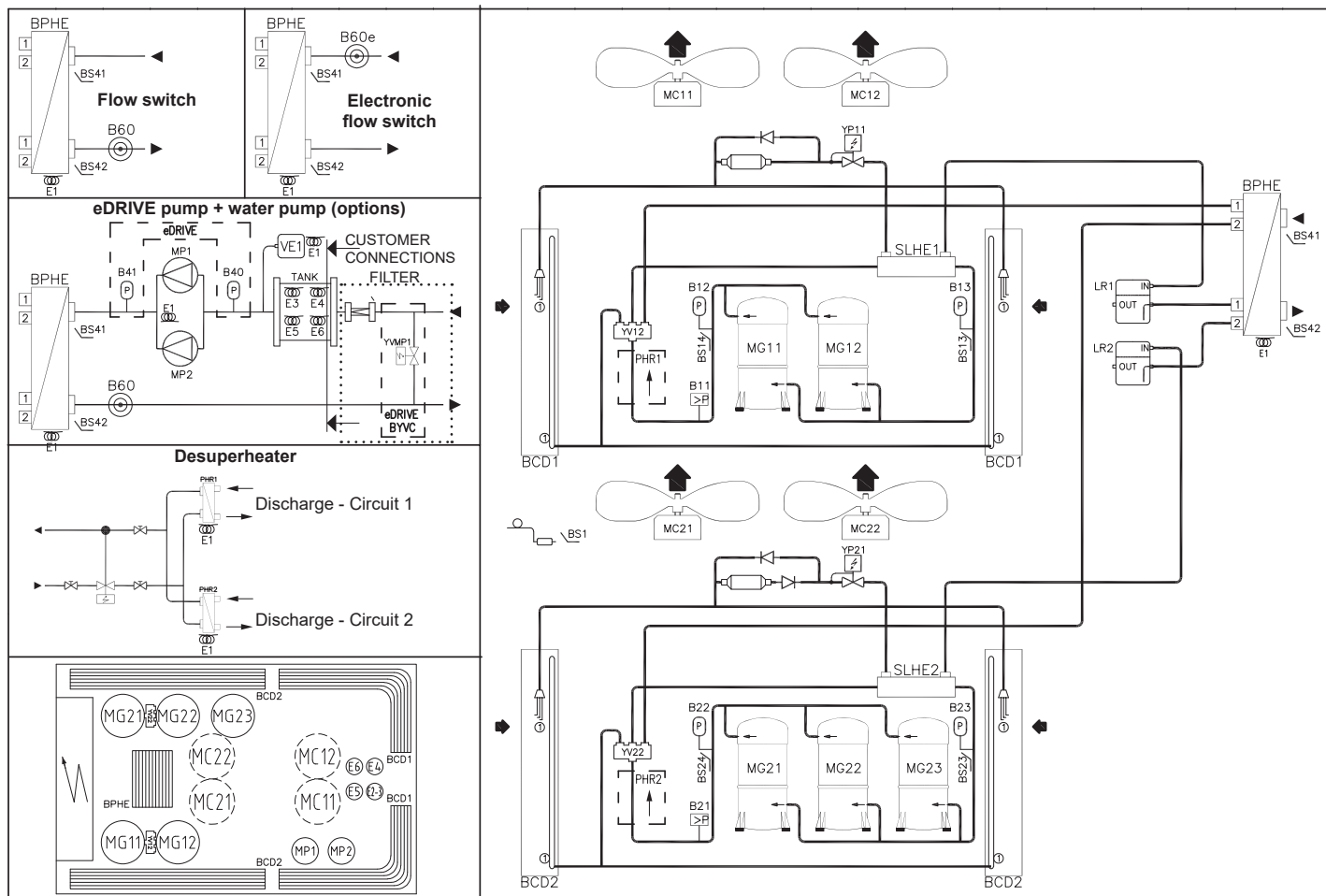

LEGEND

B11	High pressure pressostat 1
B12	High pressure transducer 1
B13	Low pressure transducer 1
B21	High pressure pressostat 2
B22	High pressure transducer 2
B23	Low pressure transducer 2
B40	Inlet water pressure
B41	Outlet water pressure
B60	Water flow switch
B60e	Electronic water flow switch
BCD	Condenser
BPHE	Evaporator (plate heat exchanger)
BS1	Outdoor temperature
BS13	Suction temperature 1
BS23	Suction temperature 2
BS24	Discharge temperature 2

LEGEND

BS41	Inlet water temperature
BS42	Outlet water temperature
E1	Evaporator antifreeze heater
E2	Antifreeze heater
E3-4-5-6	Electrical heater
LR	Liquid receiver
MC	Fan
MG	Scroll compressor
MP	Water Pump
PHR 1-2	Partial Heat Recovery
SLHE	Suction liquid heat exchanger
VE1	Expansion vessel
YP11	Electronic expansion valve - Circuit 1
YP21	Electronic expansion valve - Circuit 2
YV12-22	4 way reversing valve
YVMP1	By-pass valve

1.- GENERAL CHARACTERISTICS

1.9.- DIMENSIONS

GAC/GAH 020S-025S

STANDARD VERSION

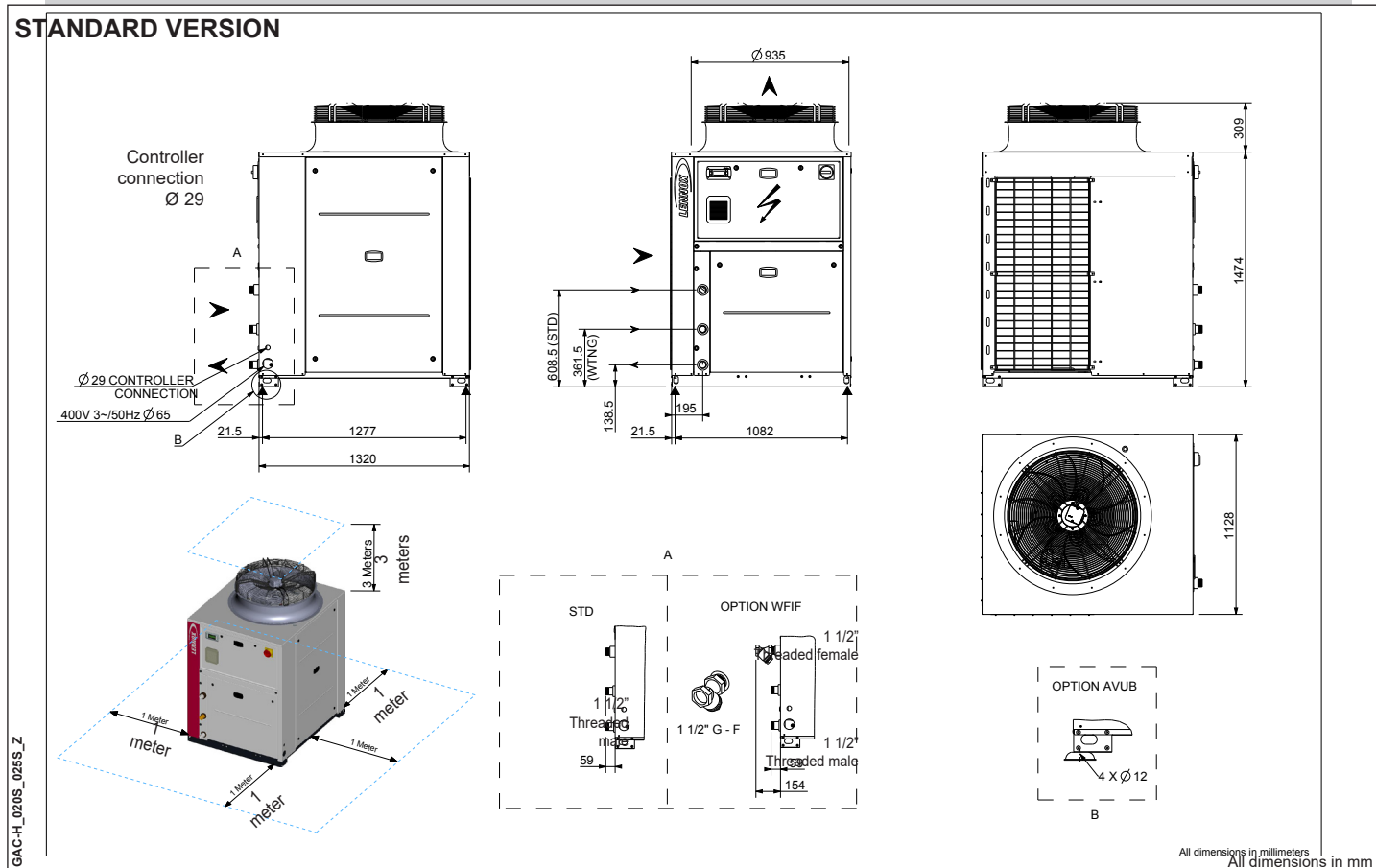

UNIT WITH STANDARD EC FANS (SEAS) OR HIGH PRESSURE EC FANS (HIPF)

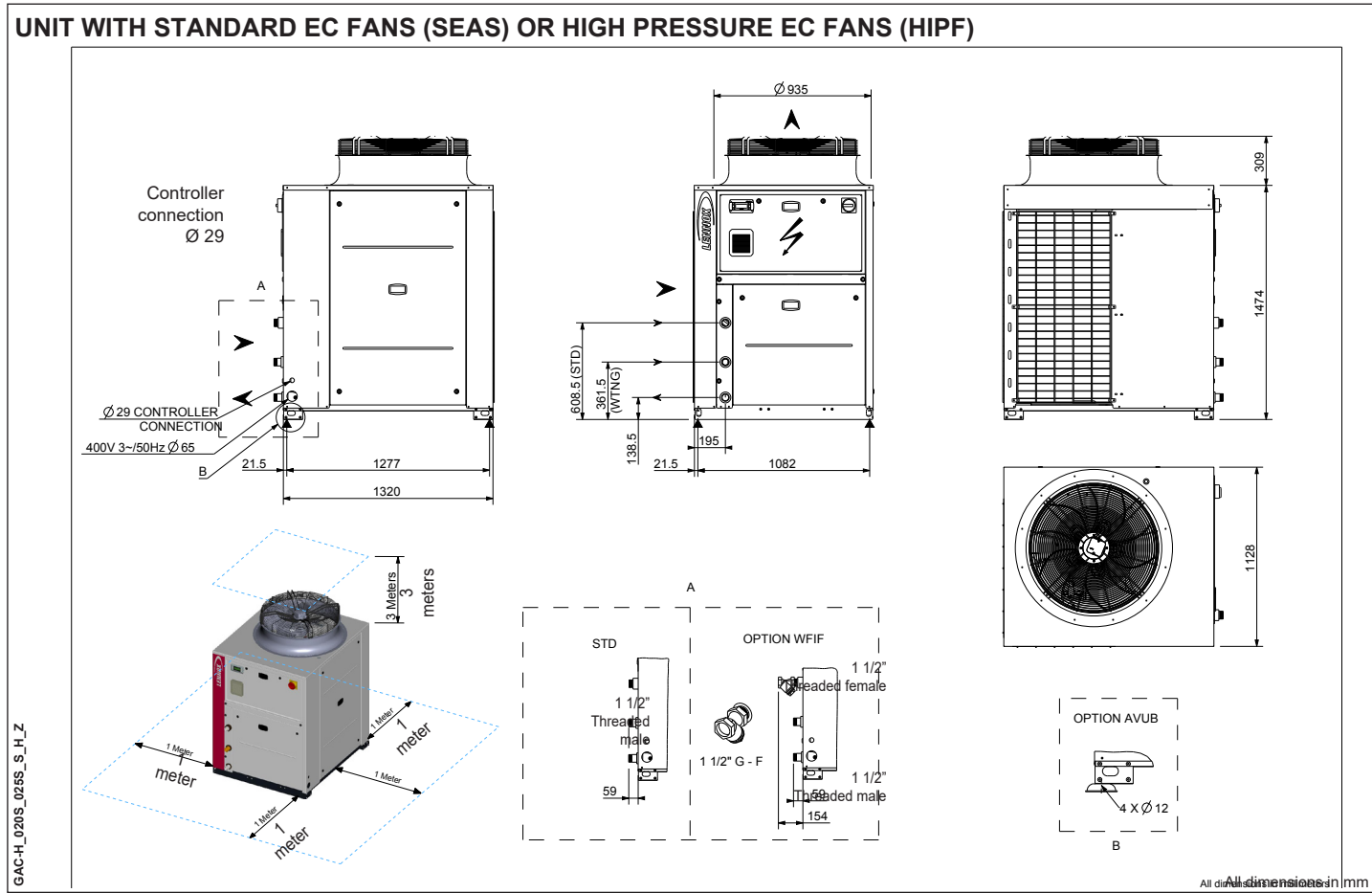

SPXX	Hydraulic module with single pump	WTNG	Water tank
DPXX	Hydraulic module with twin pump	WFIF	Water filter (supplied loose)
AVUB	Rubber anti-vibration mounts		

1.- GENERAL CHARACTERISTICS

1.9.- DIMENSIONS

GAC/GAH 030S-035S-040S-045S

STANDARD VERSION

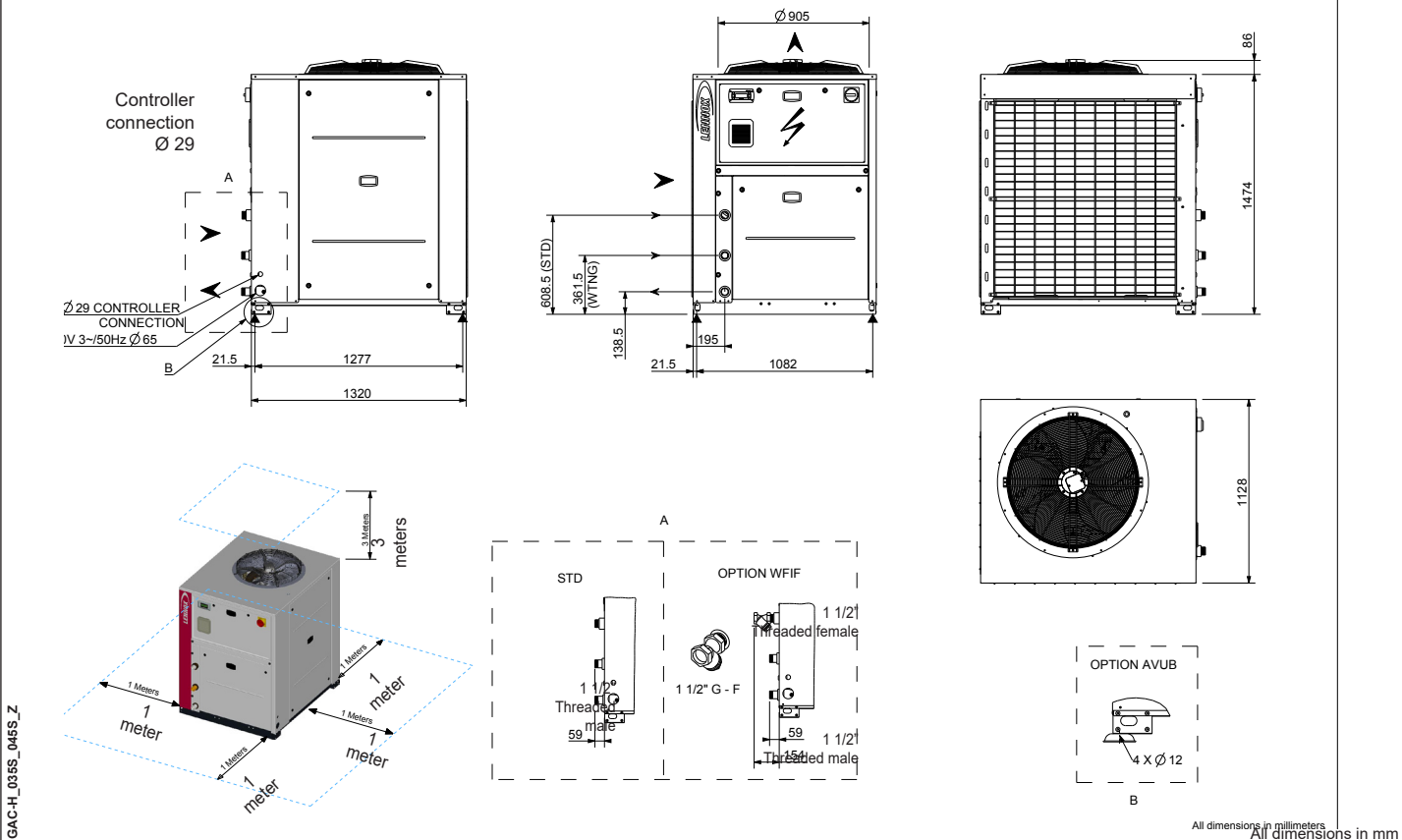

UNIT WITH STANDARD EC FANS (SEAS) OR HIGH PRESSURE EC FANS (HIPF)

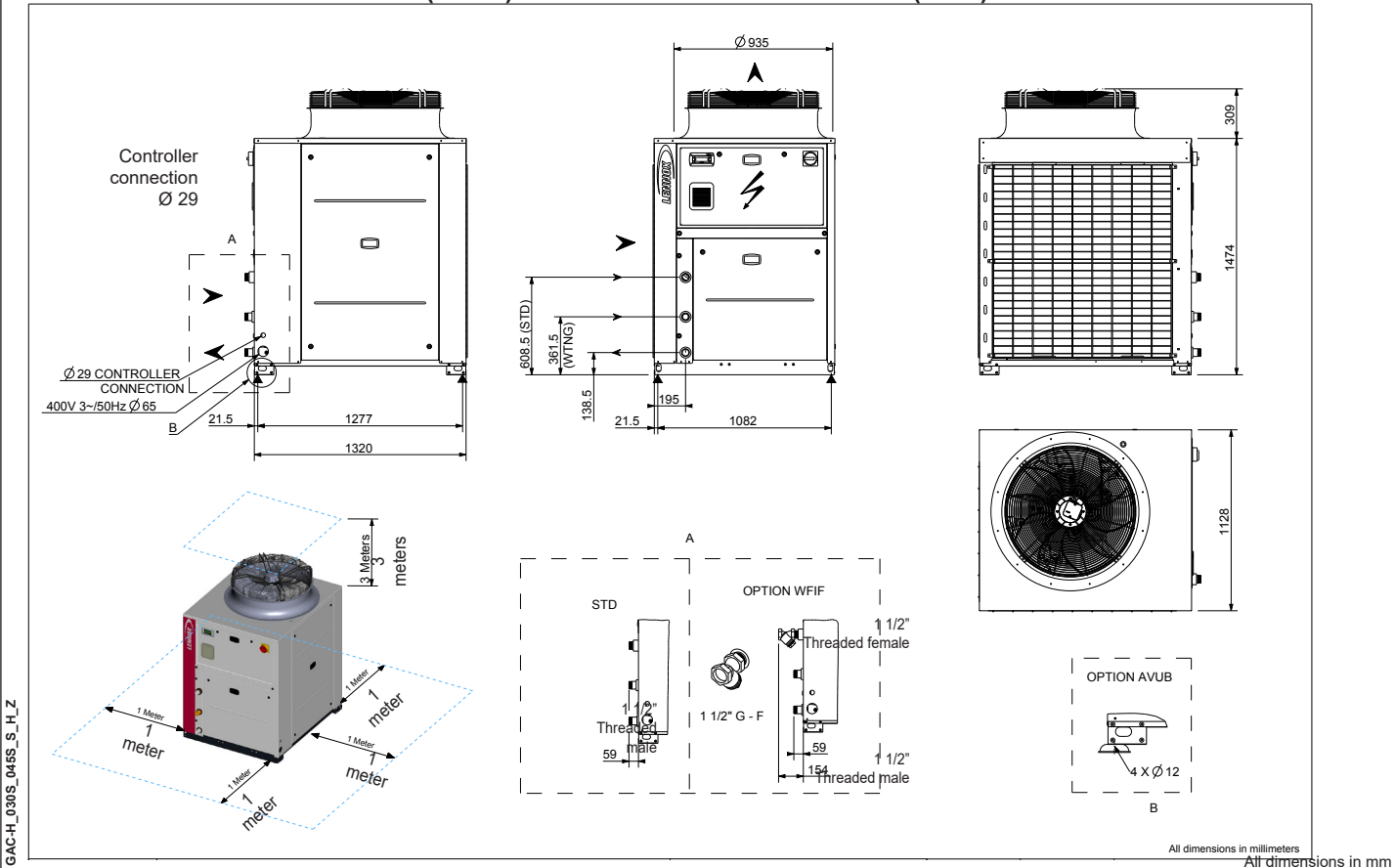

SPXX	Hydraulic module with single pump	WTNG	Water tank
DPXX	Hydraulic module with twin pump	WFIF	Water filter (supplied loose)
AVUB	Rubber anti-vibration mounts		

1.- GENERAL CHARACTERISTICS

1.9.- DIMENSIONS

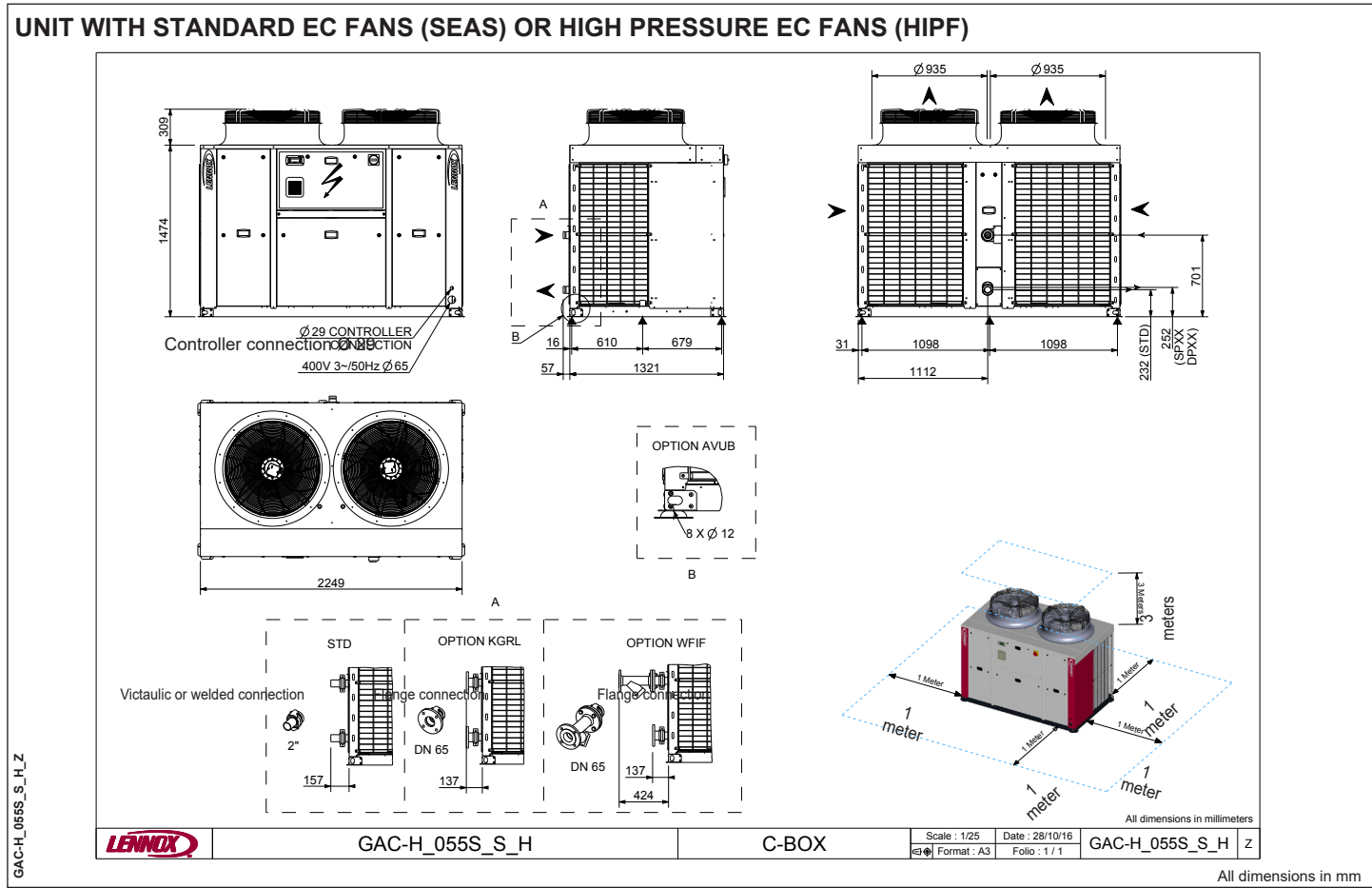
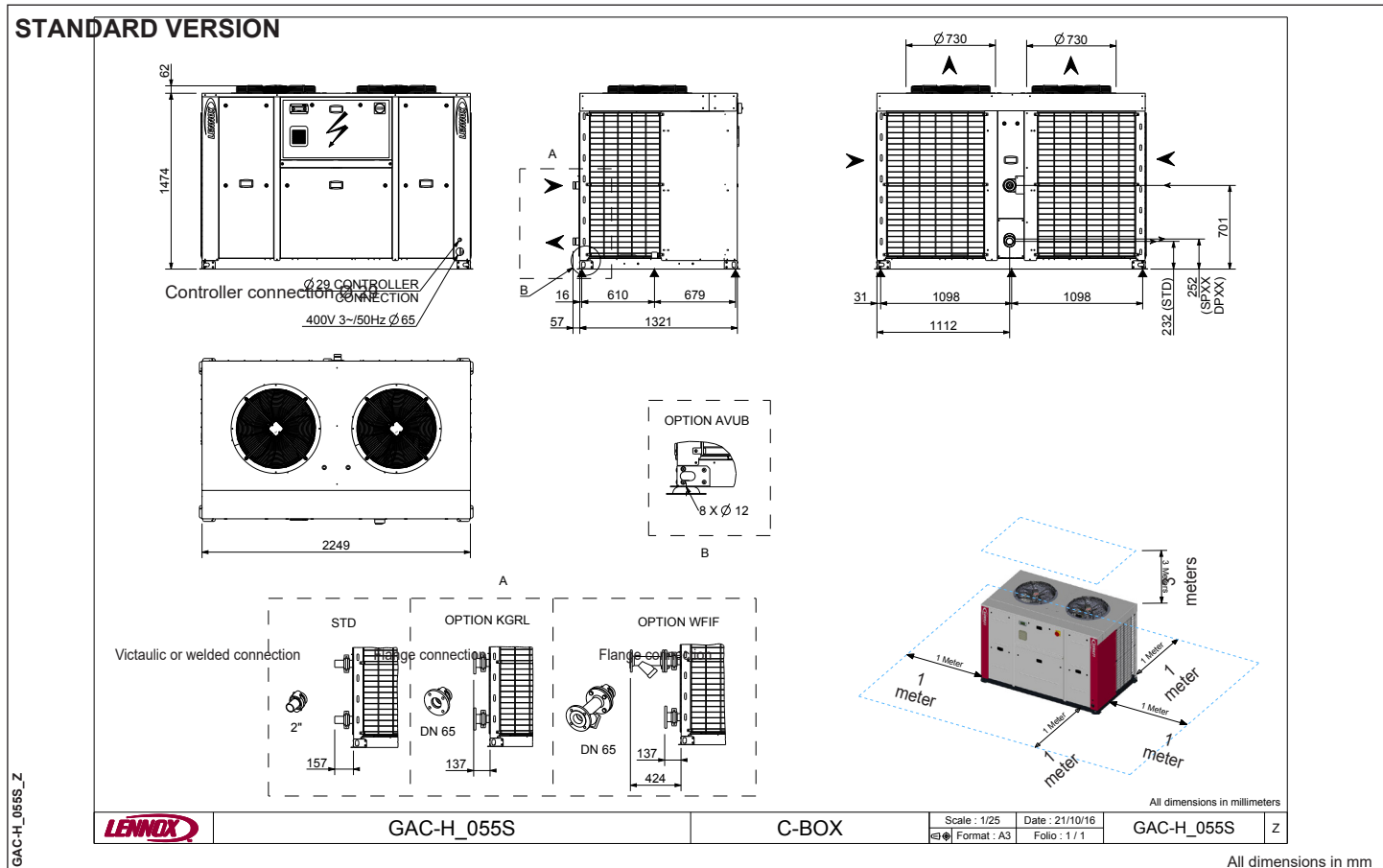

SPXX	Hydraulic module with single pump	KGRL	Flange connection
DPXX	Hydraulic module with twin pump	WFIF	Water filter (supplied loose)
AVUB	Rubber anti-vibration mounts		

1.- GENERAL CHARACTERISTICS

1.9.- DIMENSIONS

GAC/GAH 090S-110S-125S

STANDARD VERSION

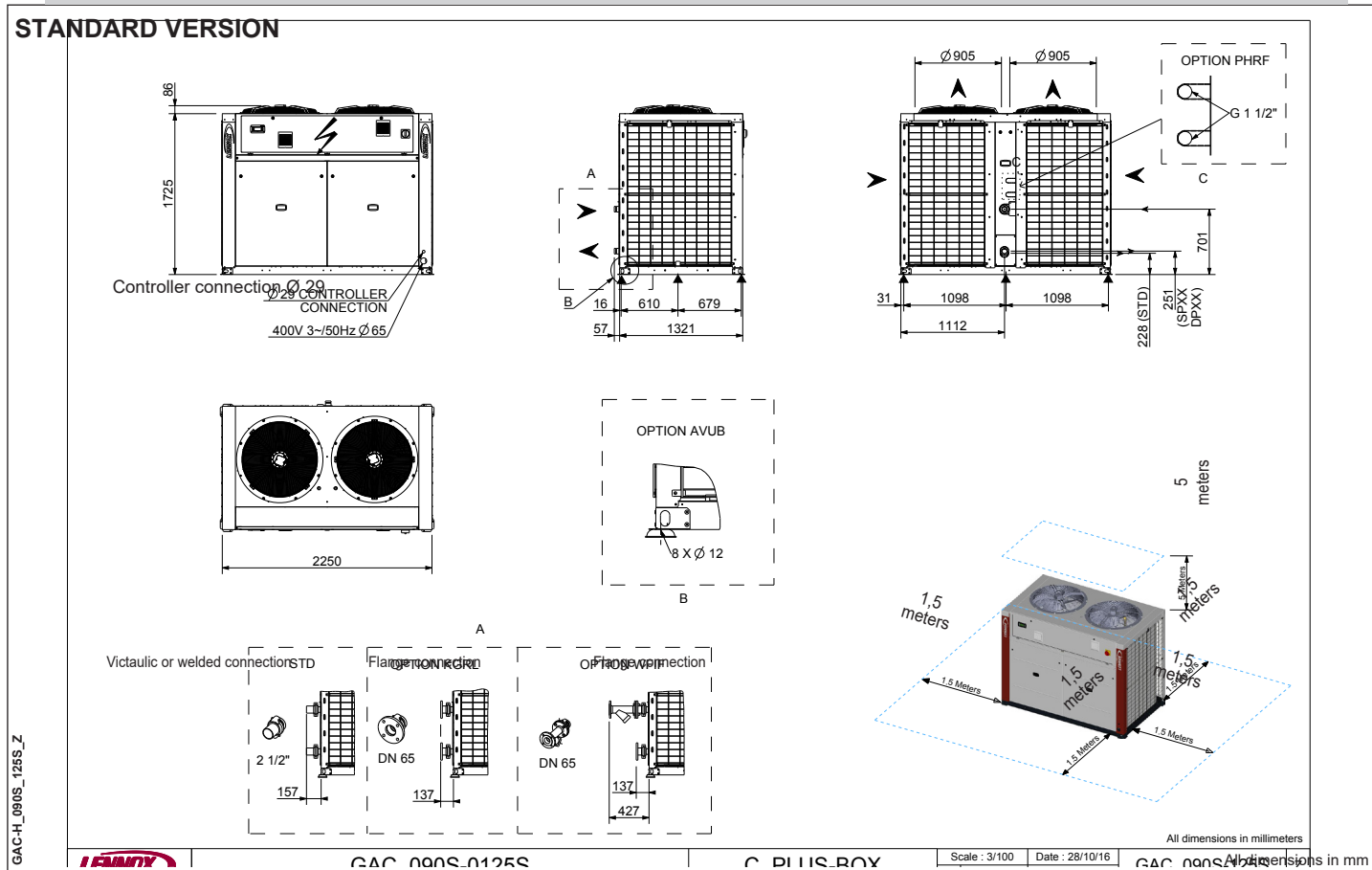

UNIT WITH STANDARD EC FANS (SEAS) OR HIGH PRESSURE EC FANS (HIPF)

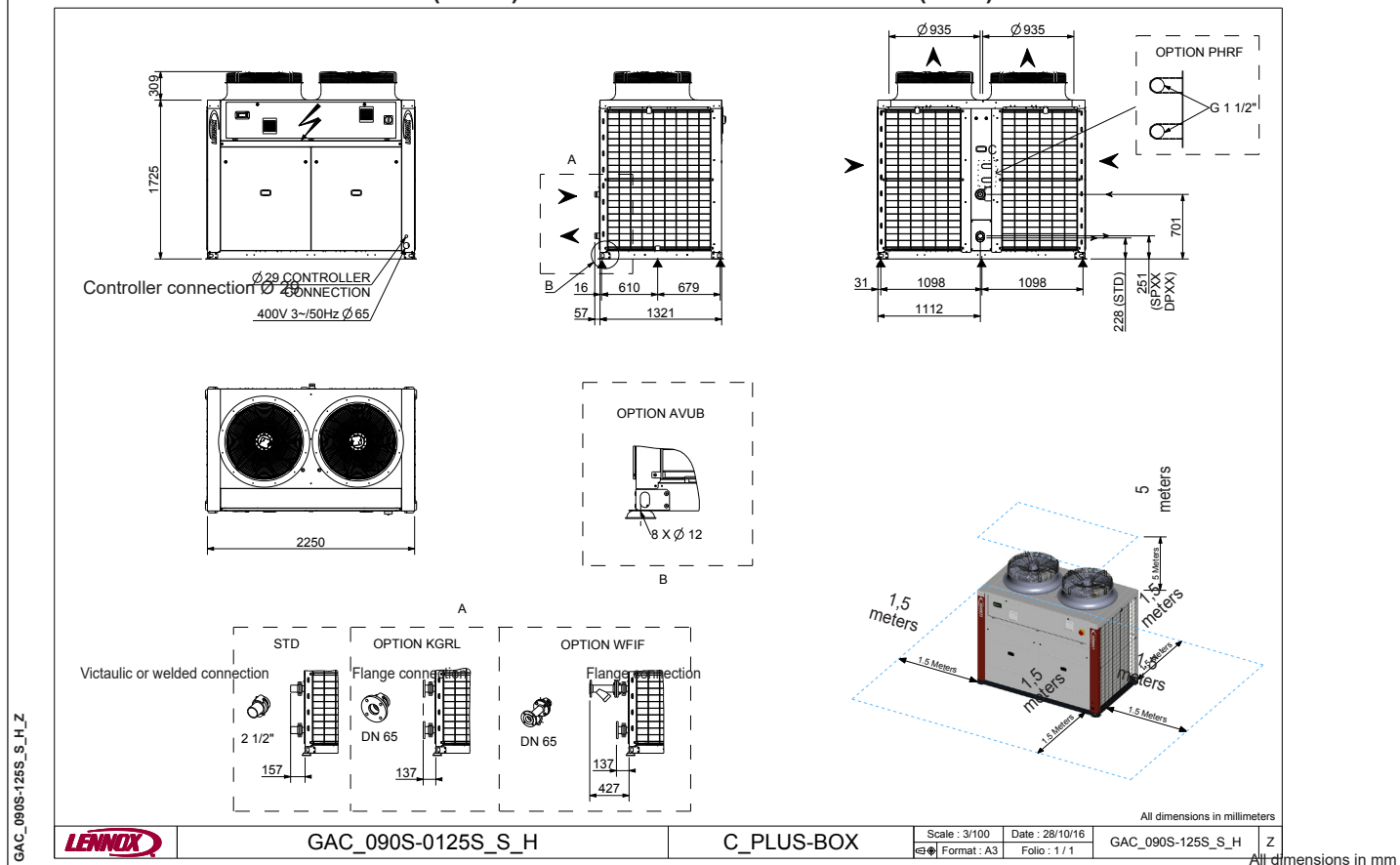

SPXX	Hydraulic module with single pump	KGRL	Flange connection
DPXX	Hydraulic module with twin pump	WFIF	Water filter (supplied loose)
AVUB	Rubber anti-vibration mounts	PHRF	Domestic hot water supply : desuperheater

1.- GENERAL CHARACTERISTICS

1.9.- DIMENSIONS

GAC 110D-125D

STANDARD VERSION

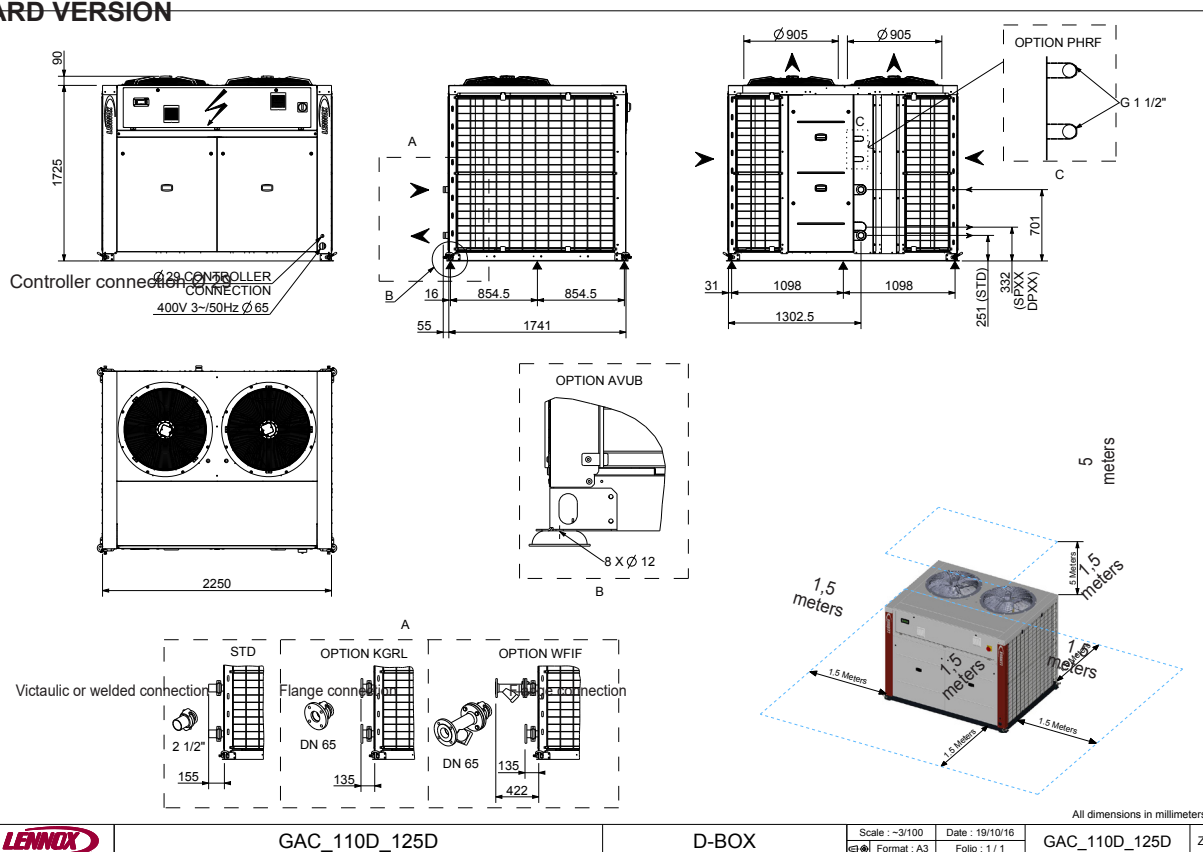

GAC_110D_125D_Z

All dimensions in mm

UNIT WITH STANDARD EC FANS (SEAS) OR HIGH PRESSURE EC FANS (HIPF)

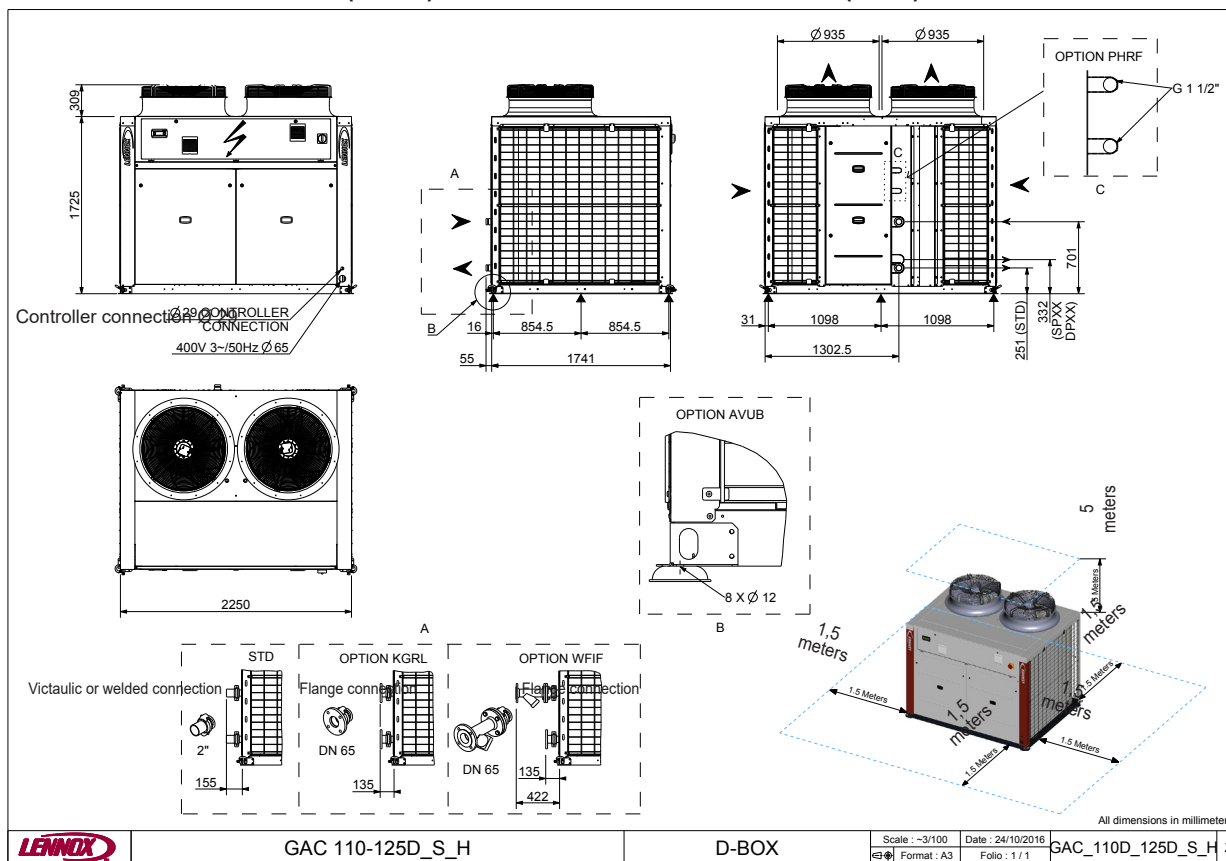

GAC_110D_125D_S_H_Z

All dimensions in mm

SPXX	Hydraulic module with single pump	KGRL	Flange connection
DPXX	Hydraulic module with twin pump	WFIF	Water filter (supplied loose)
AVUB	Rubber anti-vibration mounts	PHRF	Domestic hot water supply : desuperheater

1.- GENERAL CHARACTERISTICS

1.9.- DIMENSIONS

GAH 090S-110S-125S-125D

STANDARD VERSION

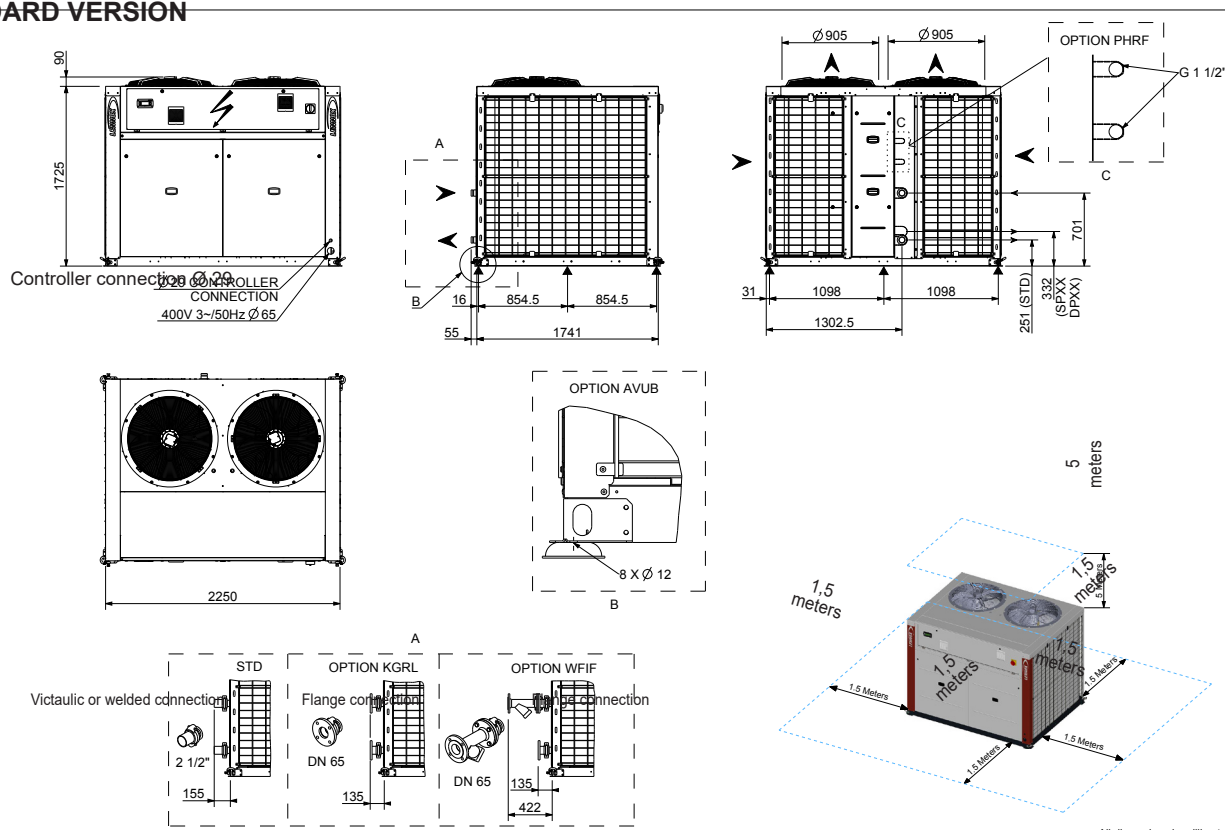

GAH_090S-125S_110D_125D

D-BOX

Scale: -3/100 Date: 19/10/16

Format: A3 Folio: 1 / 1 GAH_090S-125S_110D_125D Z

All dimensions in mm

GAH_090S_125S_110D_125D_Z

UNIT WITH STANDARD EC FANS (SEAS) OR HIGH PRESSURE EC FANS (HIPF)

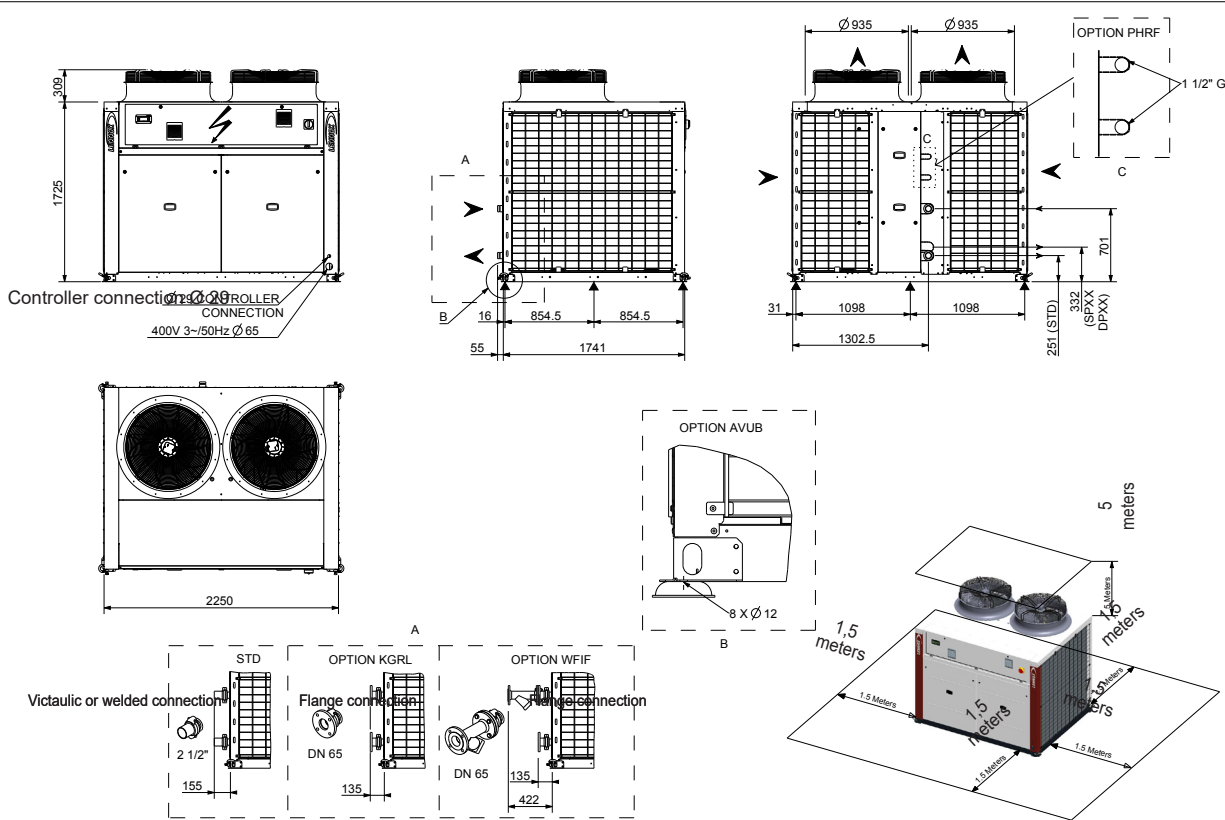

GAH_090S-125S_110D_125D_S_H

D-BOX

Scale: -3/100 Date: 25/10/16

Format: A3 Folio: 1 / 1 GAH_090S-125S_110D_125D_S_H Z

All dimensions in mm

GAH_090S_125S_110D_125D_S_H_Z

SPXX Hydraulic module with single pump

DPXX Hydraulic module with twin pump

AVUB Rubber anti-vibration mounts

KGRL Flange connection

WFIF Water filter (supplied loose)

PHRF Domestic hot water supply : desuperheater

1.- GENERAL CHARACTERISTICS

1.9.- DIMENSIONS

GAC/GAH 140D

STANDARD VERSION

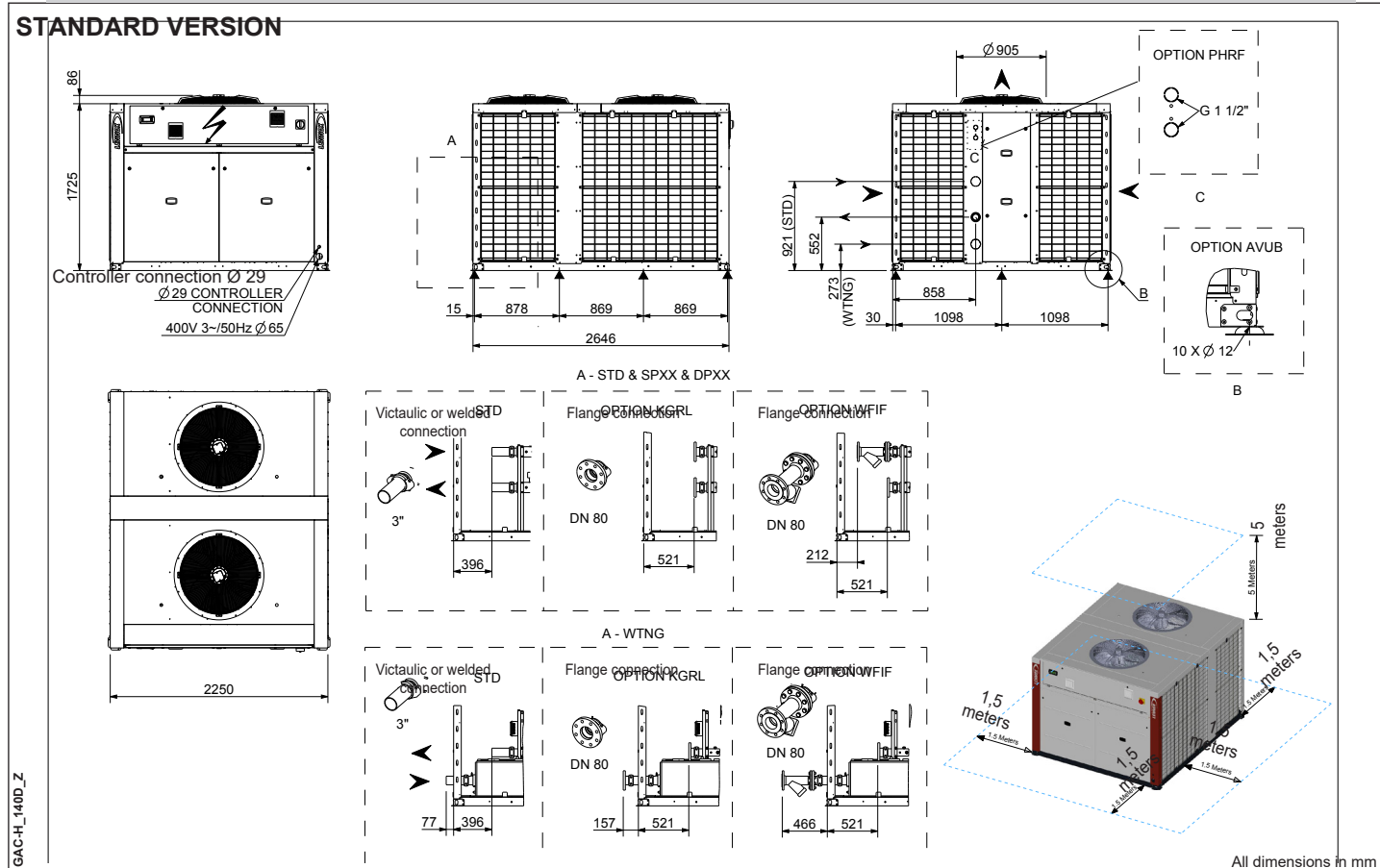

UNIT WITH STANDARD EC FANS (SEAS) OR HIGH PRESSURE EC FANS (HIPF)

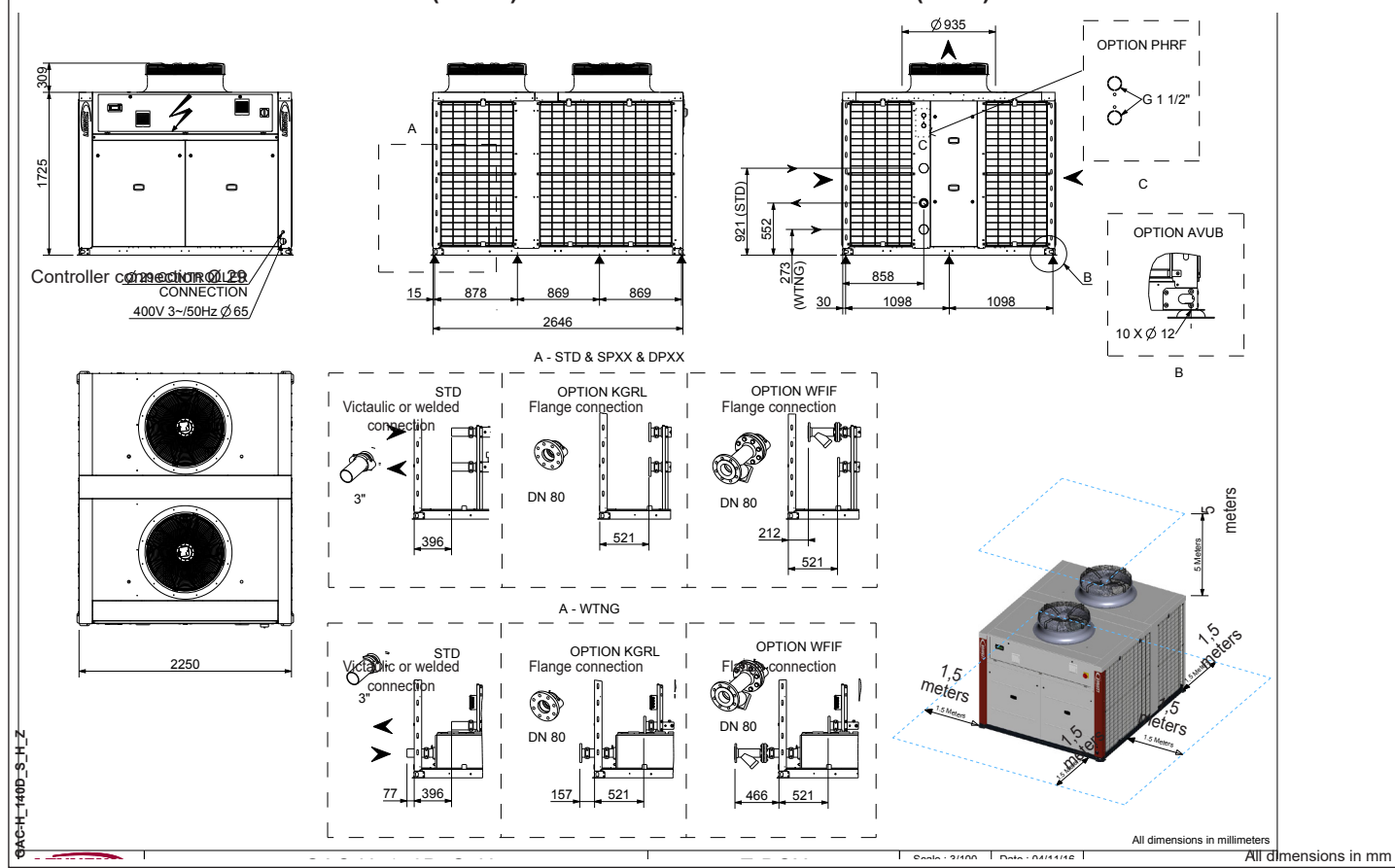

SPXX	Hydraulic module with single pump	KGRL	Flange connection	WTNG	Water tank
DPXX	Hydraulic module with twin pum	WFIF	Water filter (supplied loose)		
AVUB	Rubber anti-vibration mounts	PHRF	Domestic hot water supply : desuperheater		

1.- GENERAL CHARACTERISTICS

1.9.- DIMENSIONS

GAC/GAH 160D - 185D

STANDARD VERSION

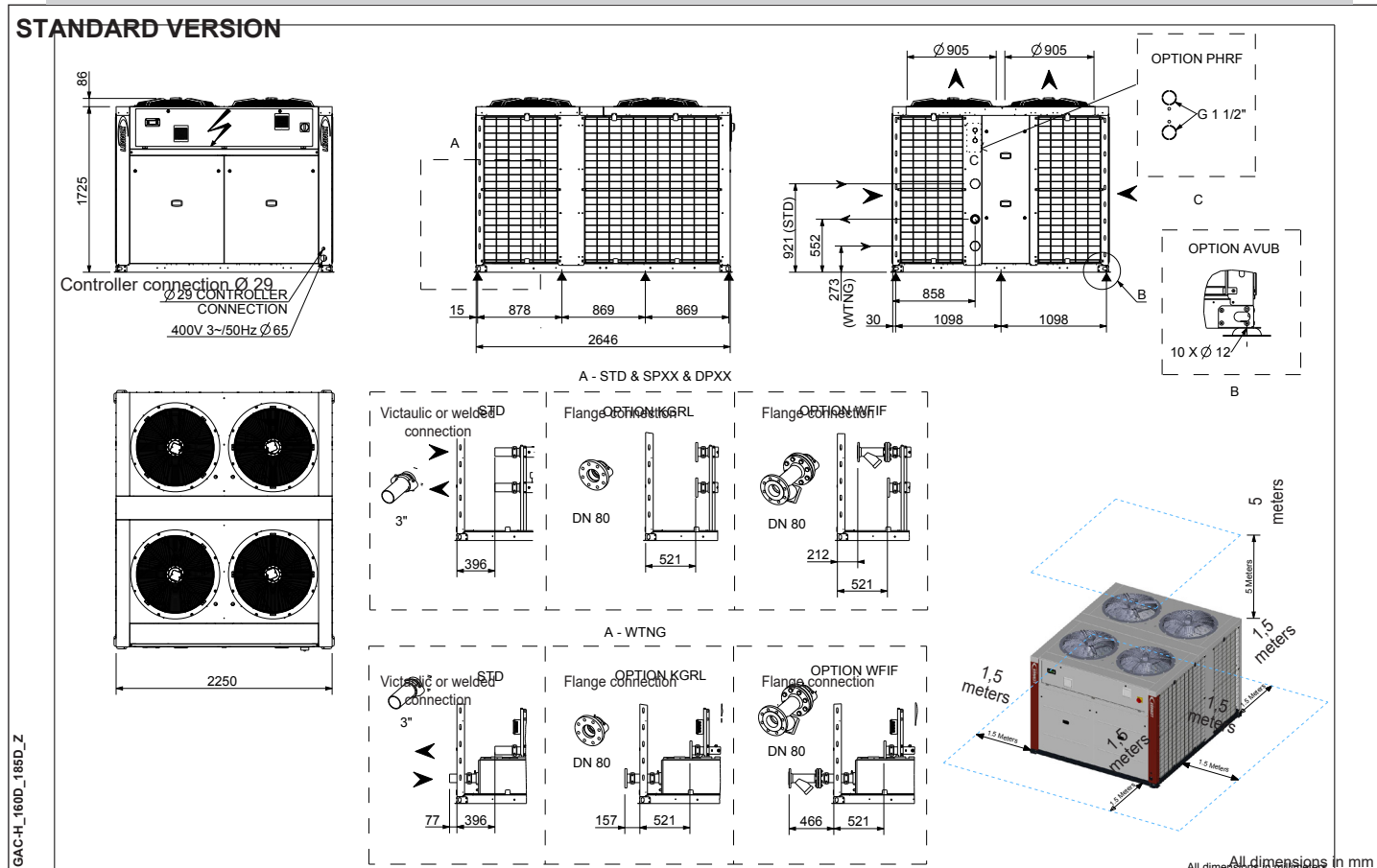

GAC-H_160D_185D_Z

All dimensions in mm

UNIT WITH STANDARD EC FANS (SEAS) OR HIGH PRESSURE EC FANS (HIPF)

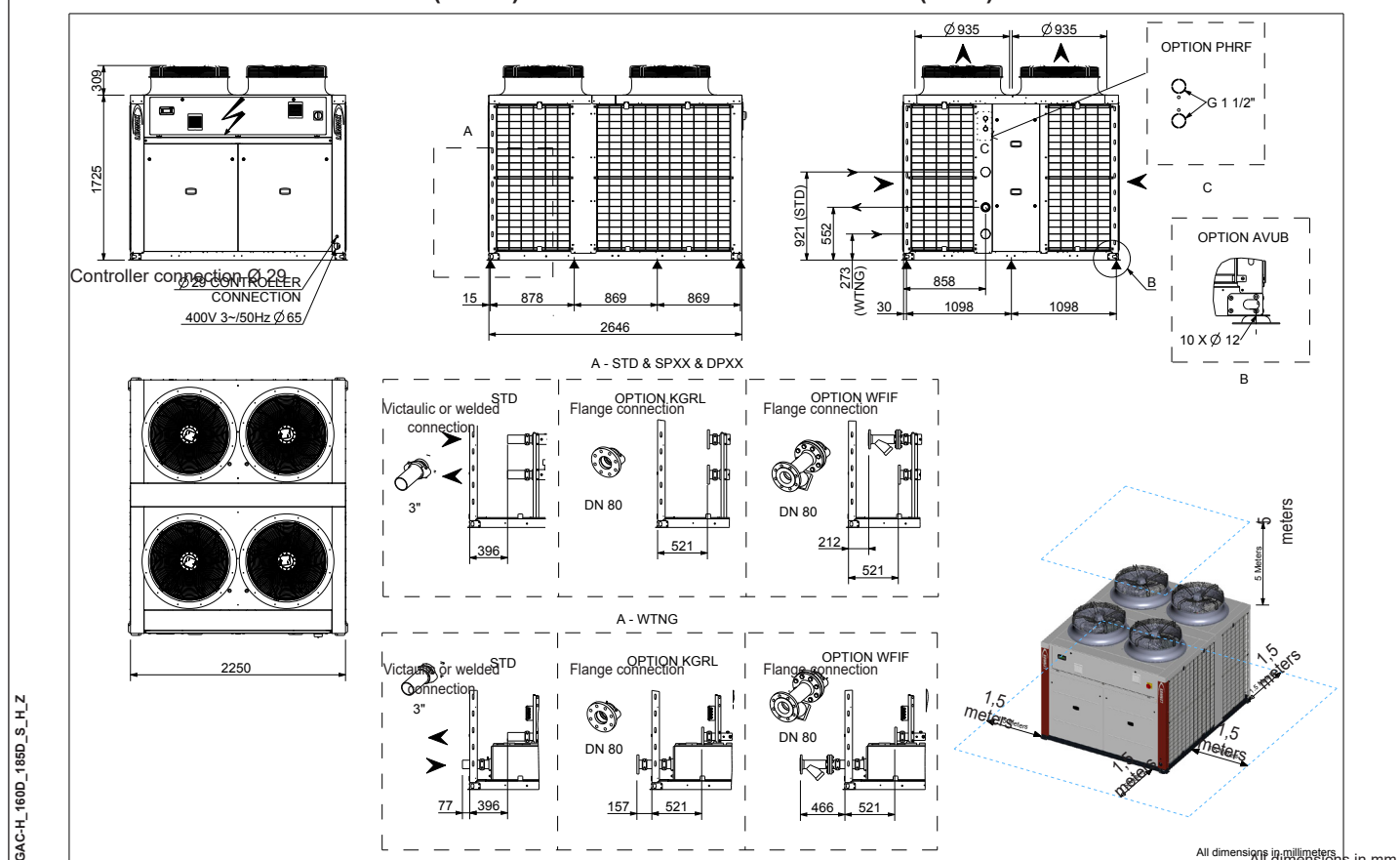

GAC-H_160D_185D_S_H_Z

All dimensions in mm

SPXX	Hydraulic module with single pump	KGRL	Flange connection	WTNG	Water tank
DPXX	Hydraulic module with twin pum	WFIF	Water filter (supplied loose)		
AVUB	Rubber anti-vibration mounts	PHRF	Domestic hot water supply : desuperheater		

2.- INSTALLATION

2.1 TRANSPORT - HANDLING

Equipment designed to withstand transport and handling according to the established protocol (for the handling protocol, please refer to the installation instructions for the relevant product range).

All unloading operations must be carried out with suitable equipment (crane, forklift truck, etc.).

Optional removable handling rings are available for certain products.

When using a forklift truck, you must respect the positions and the direction of handling indicated on the products.

The equipment must be handled with care to avoid damage to the bodywork, pipework, condenser, etc.

Controls and delivery checks

After the unit has been received, when it is ready to be installed or reinstalled, and before it is started up, it must be inspected for damage. On receipt of a new equipment please check the following points. It is the customer's responsibility to ensure that the products are in good working order (fill the check list page 62):

The exterior has not been damaged in any way.

The lifting and handling equipment are suitable for the equipment and comply with the specifications of the handling instructions enclosed here-in.

Accessories ordered for on site installation have been delivered and are in good working order.

If the unit is delivered with its operating charge of refrigerant, that there has been no leakage (use an electronic detector).

The equipment supplied corresponds to the order and matches the delivery note.

If the product is damaged, exact details must be confirmed in writing by registered post to the shipping company within 48 hours of delivery (working days).

A copy of the letter must be addressed to LENNOX and the supplier or distributor for information purposes. Failure to comply will invalidate any claim against the shipping company.

Please be reminded that LENNOX is not responsible for off-loading and positioning.

Unit Nameplate

The rating plate provides a complete reference for the model and ensures that the unit corresponds to the model ordered. It states the electrical power consumption of the unit on start-up, its rated power and its supply voltage.

The supply voltage must not deviate beyond +5/-5 %.

The start-up power is the maximum value likely to be achieved for the specified operational voltage. The customer must have a suitable electrical supply. It is therefore important to check whether the supply voltage stated on the unit's rating plate is compatible with that of the mains electrical supply.

The rating plate also states :

- Year of manufacture
- Weight of the unit
- Type of refrigerant used
- Required charge for each compressor circuit.
- Operating Pressure max/min
- Operating Temperature max/min

		Lennox Refac, S.A. Villalonguejar 4 09001 Burgos España		 1181		
Unit type:		GAC030SM1M				
Serial Nr:		10089360ES03170331				
	Voltage (V)	Phase (Ph)	Frecuency (Hz)	Current (A)		
Elec	400	III	50	Nominal	Starting	
Elec Aux.	24	1	50	34,70	94,70	
			Min Max			
			LP	HP	LP HP	
Pressure (PS) (bar)			-1	-1	28 43	
Temperature (T S) (°C)			-20	-20	50 110	
Storage Temperature (T S)			-30		50	
LP: Low Pressure side / HP: High Pressure						
Capacities (KW)		Ref Charge (Kg)			Dates	
Cooling	Heating	C1	C2	C3	C4	Prod. Test
31,7		4,4				13/03/2017
Fluid		Fluid group			Weight (Kg)	
R410A GWP=2088		2			342	
This product is used for Air Conditioning. Contains fluorinated greenhouse gases covered by the Kyoto protocol. Hermetically sealed						

*GWP : Global warming potential

2.- INSTALLATION

When unpacking the machine, have a correct segregation of non-hazardous waste coming from packaging: Plastic film or other plastic elements, metal strips, wood and pallets, through authorized dealers, or segregate them in the containers destined for this purpose

Follow the installation instructions established in this manual to avoid disturbing noise caused by movement or shocks due to deficient installation of the unit.

2.2.- SITE AND SHIPPING GUIDANCE



All INSTALATION, SERVICE, and MAINTENANCE operations must be carried out by QUALIFIED PERSONNEL

The unit must be transported in a HORIZONTAL POSITION on its wooden pallet. Any other position may cause serious damage to the machine.

When the unit is received, it should be checked to assure that there are no bumps or other damage, following the instructions on the packaging. If there is damage, the unit may be rejected by notifying the LENNOX Distribution Departent and reporting why the machine is unacceptable on the transport agent's delivery notice. Any later complaint or claim made to the LENNOX Distribution Departent, for this type of anomaly, cannot be considered under the Guarantee.

Sufficient space must be allowed to facilitate placement of the unit. The unit may be mounted outdoors. There should be adequate drainage around the unit.

In heat pump units during defrost cycle, the units produce a great amount of water melting the ice off coils.

If you wish to drain the water, adequate drainage should be installed behind the unit to collect and carry out the water where desired.



When positioning the unit, be sure that the Rating Plate will always be visible since this data will be necessary to assure proper maintenance.

It is advisable to unpack the unit at the place where the unit is going to be installed, to avoid damages during manage.

2.3.- UNIT LIFTING

How to hoist the unit

If unloading and placement requires the use of a crane, then secure the suspension cables as shown in the figure.

The unit can only be lifted and moved by its base.

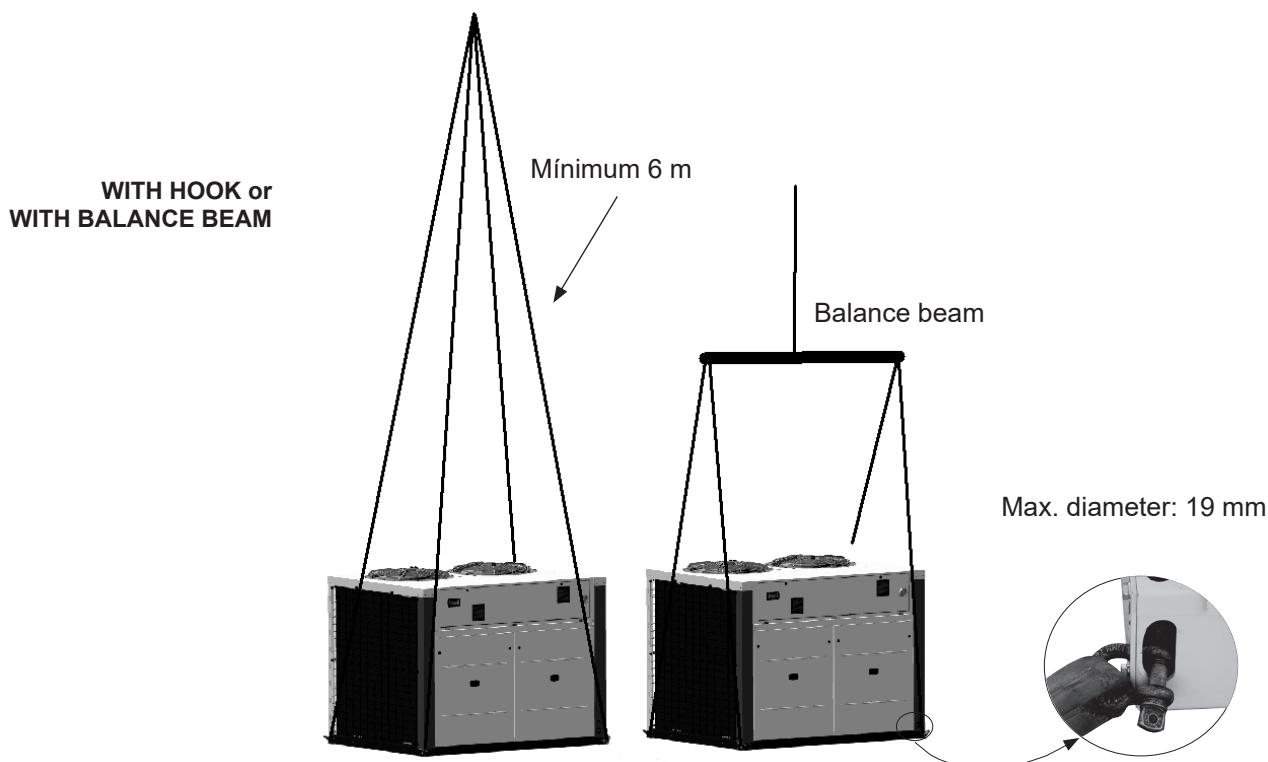

NOTE: Use slingers of 6 m with the hook in order to prevent pressure on the top of the unit because it can be damaged. Whenever it is possible, use balance beam.

2.- INSTALLATION

2.4.- ANTIVIBRATION MOUNTING

1. Mounting on a low sensibility zone

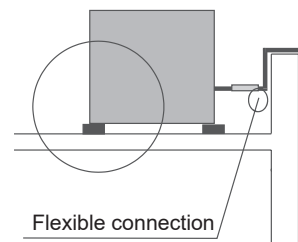
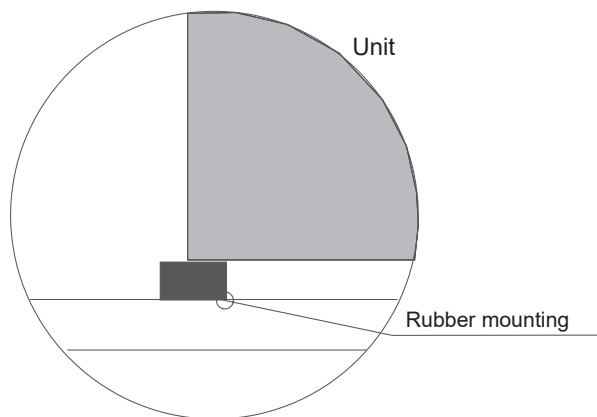

2. Mounting on a medium sensibility zone

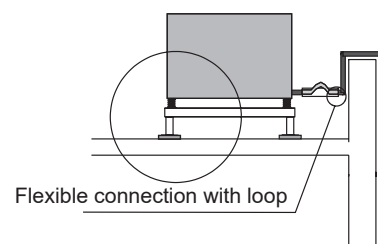
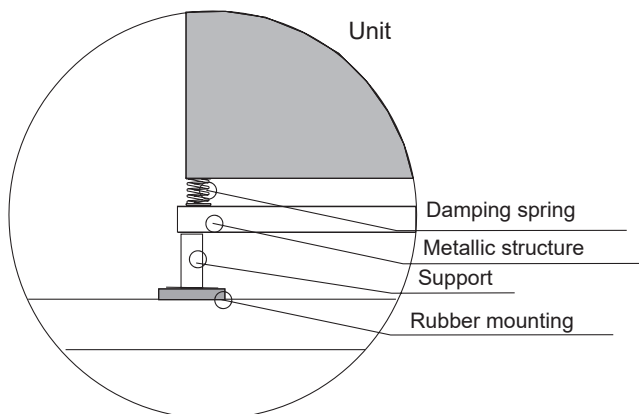

3. Mounting on a high sensibility zone (Check floor load)

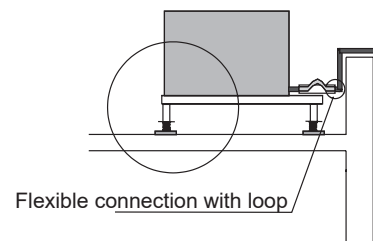
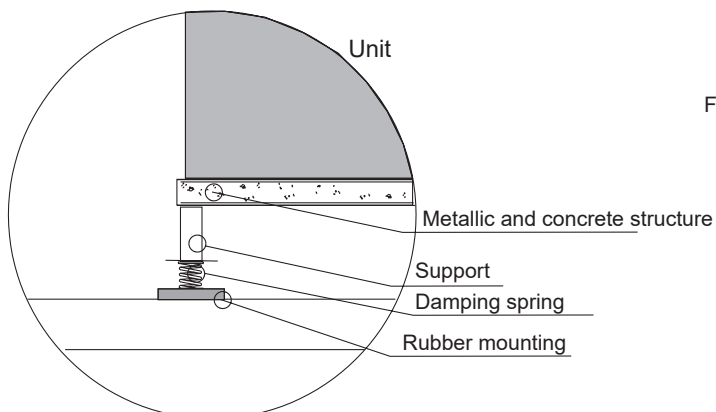

2.- INSTALLATION

2.5.- WEIGHT DISTRIBUTION (kg) - Units with water tank

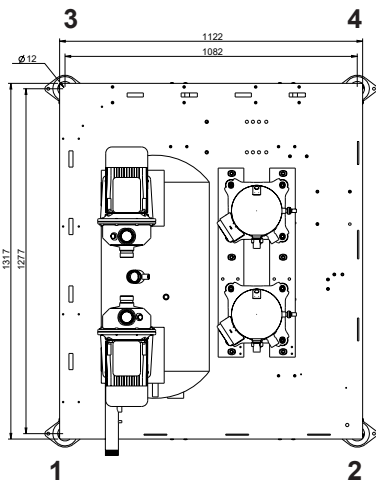

Nr. Position	STD Unit					With Dual Pump					With Dual Pump & Water tank				
	1	2	3	4	Total (Kg)	1	2	3	4	Total (Kg)	1	2	3	4	Total (Kg)
GAC020SM2M	81	74	78	79	312	92	88	93	84	357	135	124	135	107	502
GAC025SM2M	83	75	80	81	319	94	90	95	85	364	137	126	137	108	509
GAC030SM2M	89	81	86	87	342	101	97	101	91	390	144	133	144	114	535
GAC035SM2M	95	86	92	93	366	107	103	108	97	414	151	139	151	119	559
GAC040SM2M	96	88	93	95	371	108	104	109	98	419	152	140	152	120	564
GAC045SM2M	100	91	97	98	386	112	108	113	102	434	156	143	156	123	579
GAH020SM2M	87	79	84	85	335	98	94	99	89	380	142	130	142	111	525
GAH025SM2M	88	80	85	87	341	100	96	100	90	386	143	132	143	113	531
GAH030SM2M	96	87	93	94	370	108	104	109	98	418	152	139	152	119	563
GAH035SM2M	102	93	99	100	394	114	110	115	103	442	158	145	158	125	587
GAH040SM2M	104	94	100	102	400	116	111	116	105	448	160	147	160	126	593
GAH045SM2M	109	99	105	107	421	121	116	122	110	469	166	152	166	130	614

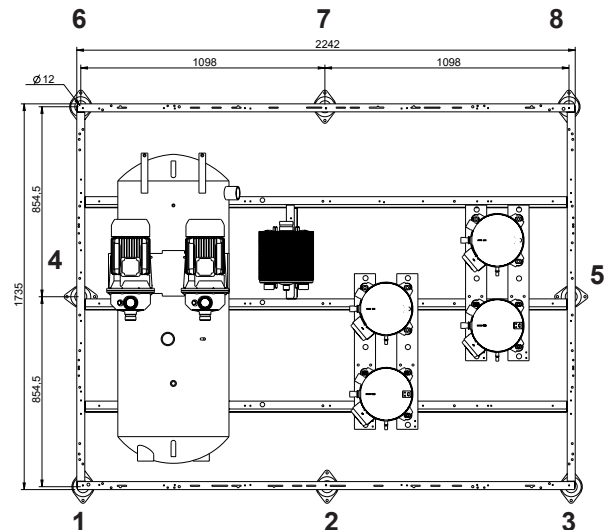
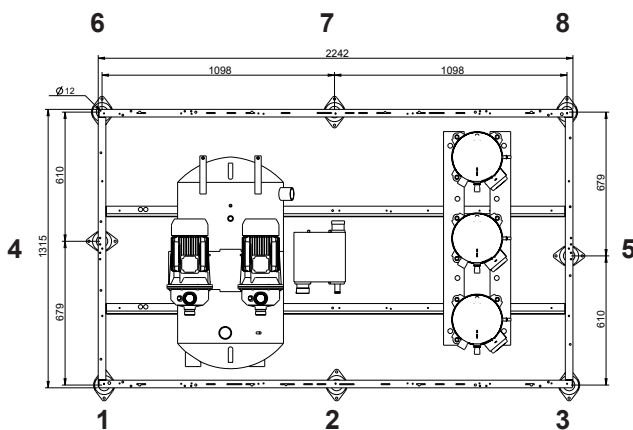

Nr. Position	STD Unit									With Dual Pump								With Dual Pump & Water tank									
	1	2	3	4	5	6	7	8	Total (Kg)	1	2	3	4	5	6	7	8	Total (Kg)	1	2	3	4	5	6	7	8	Total (Kg)
GAC055SM2M	79	72	68	72	69	77	74	90	602	90	79	75	89	77	86	79	85	660	133	115	98	134	105	124	115	132	955
GAC060SM2M	83	75	71	75	72	80	77	93	627	94	82	77	92	79	89	82	88	685	137	118	101	137	108	127	118	135	980
GAC070SM2M	87	79	74	79	76	84	81	98	657	98	86	81	96	83	93	86	92	715	141	121	104	141	111	131	121	139	1010
GAC080SM2M	93	85	80	85	81	90	87	105	706	105	92	86	103	89	99	92	99	764	148	127	109	148	116	138	127	146	1059
GAH055SM2M	85	77	73	77	74	83	79	96	645	96	84	79	95	82	91	84	91	703	139	120	103	140	110	130	120	137	998
GAH060SM2M	90	82	77	82	79	87	84	102	683	101	89	84	100	86	96	89	96	741	144	124	106	145	114	135	124	143	1036
GAH070SM2M	94	86	81	86	82	92	88	107	715	106	93	87	104	90	100	93	100	773	149	128	110	149	117	139	128	147	1068
GAH080SM2M	102	93	87	93	89	99	95	115	773	114	100	94	112	96	108	100	107	831	157	135	116	158	124	146	135	155	1126
GAC090SM2M	103	114	116	103	110	103	114	113	876	118	120	121	122	113	118	113	117	941	169	163	169	169	156	163	156	156	1301
GAC110SM2M	105	116	118	105	112	105	116	115	892	120	122	123	124	115	120	115	119	957	171	165	171	171	158	165	158	158	1317
GAC125SM2M	105	116	118	105	112	105	116	115	892	120	122	123	124	115	120	115	119	957	171	165	171	171	158	165	158	158	1317
GAC110DM2M	117	129	131	117	124	117	129	128	989	132	134	136	137	127	132	127	131	1054	180	178	177	179	170	178	177	176	1414
GAC125DM2M	118	130	132	118	125	118	130	129	1000	133	135	137	138	128	133	128	132	1065	181	180	178	180	171	180	178	177	1425
GAH090SM2M	109	121	122	109	116	109	121	120	927	124	126	128	129	119	124	119	123	992	172	170	169	171	162	170	169	168	1352
GAH110SM2M	117	129	131	117	124	117	129	128	995	133	135	137	138	127	133	127	131	1060	180	179	178	180	170	179	178	177	1420
GAH125SM2M	117	129	131	117	124	117	129	128	995	133	135	137	138	127	133	127	131	1060	180	179	178	180	170	179	178	177	1420
GAH110DM2M	125	138	140	125	133	125	138	137	1061	141	143	145	146	135	141	135	140	1126	189	187	186	188	178	187	186	185	1486
GAH125DM2M	127	139	142	127	134	127	139	138	1073	142	145	147	148	137	142	137	141	1138	190	189	187	190	180	189	187	187	1498

2.- INSTALLATION

2.5.- WEIGHT APPROXIMATE DISTRIBUTION (kg)

Units with water tank

Nr. Position	STD Unit										Total (Kg)
	1	2	3	4	5	6	7	8	9	10	
GAC140DM2M	151	150	153	149	147	143	142	123	122	122	1401
GAC160DM2M	163	161	164	160	158	154	152	133	131	131	1508
GAC185DM2M	170	169	172	167	165	161	159	139	137	137	1575
GAH140DM2M	160	159	162	157	156	151	150	131	129	129	1483
GAH160DM2M	172	170	174	169	167	162	161	140	139	139	1592
GAH185DM2M	180	178	181	176	175	170	168	146	145	145	1663

Nr. Position	With Dual Pump										Total (Kg)
	1	2	3	4	5	6	7	8	9	10	
GAC140DM2M	162	165	161	156	155	150	149	137	137	146	1518
GAC160DM2M	174	177	172	167	166	161	159	146	146	156	1625
GAC185DM2M	181	184	179	174	173	168	166	152	152	162	1692
GAH140DM2M	171	174	170	165	163	158	157	144	144	154	1600
GAH160DM2M	183	186	181	176	174	169	168	154	154	164	1709
GAH185DM2M	190	194	189	183	182	176	174	160	160	171	1780

Nr. Position	With Dual Pump & Water tank										Total (Kg)
	1	2	3	4	5	6	7	8	9	10	
GAC140DM2M	191	187	189	191	193	191	195	243	248	271	2098
GAC160DM2M	201	196	198	201	203	201	205	256	260	284	2205
GAC185DM2M	207	202	205	207	209	207	211	264	268	293	2272
GAH140DM2M	198	194	196	198	201	198	203	253	257	281	2180
GAH160DM2M	208	204	206	208	211	208	213	266	270	295	2289
GAH185DM2M	215	210	212	215	217	215	220	274	279	304	2360

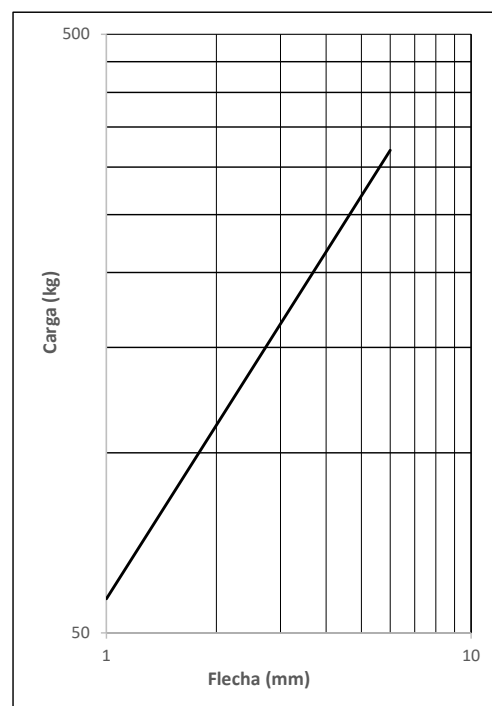
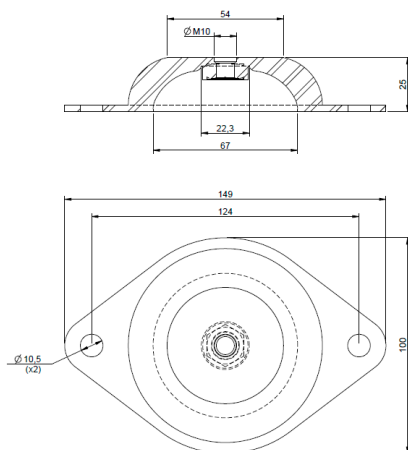
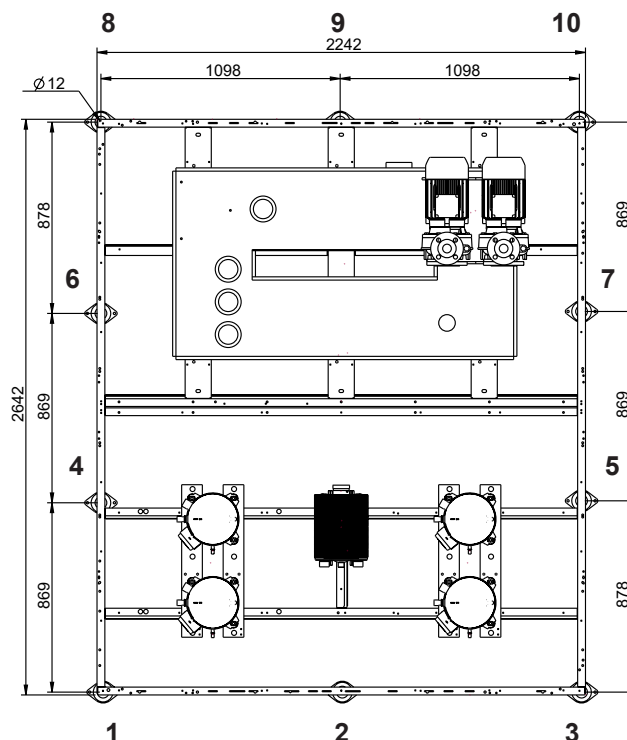

2.- INSTALLATION

2.6.- INSTALLATION CLEARANCES

Clearance around the unit, for any unit version. Keep this space free around the unit for installation. Failure to install the units as shown will impact performance and reliability.

STANDARD VERSION

UNIT WITH STANDARD EC FANS (SEAS) OR HIGH PRESSURE EC FANS (HIPF)

**GAC/GAH
020S-025S-035S-045S**

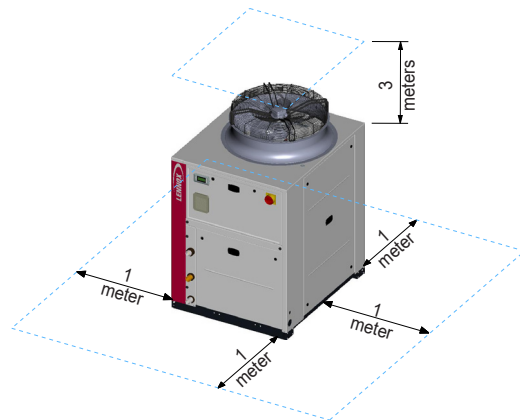
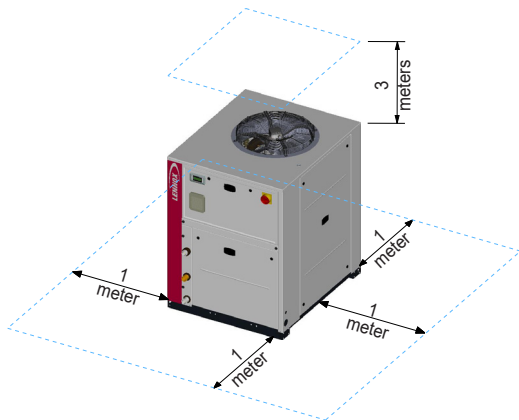

**GAC/GAH
055S**

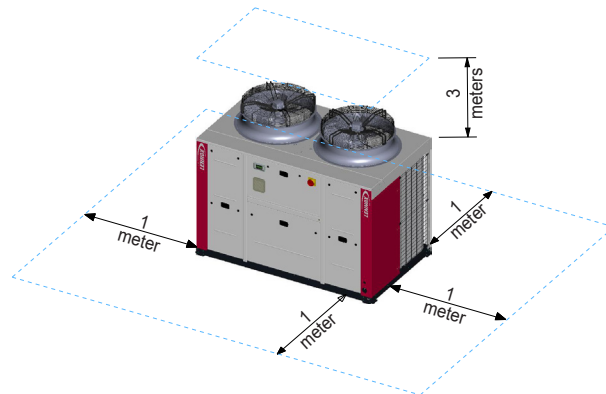
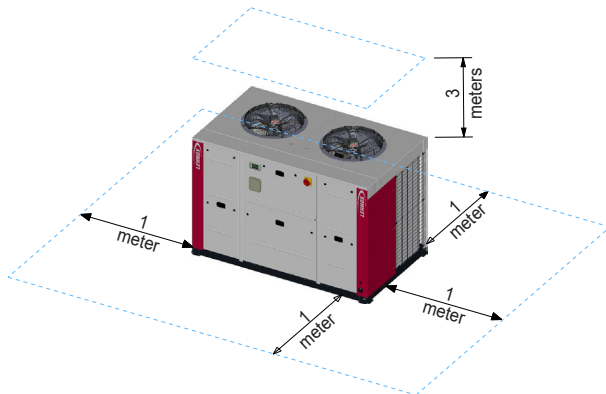

**GAC/GAH
060S-070S-080S**

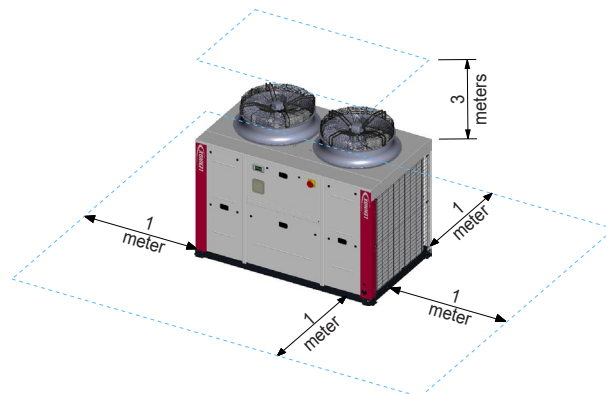
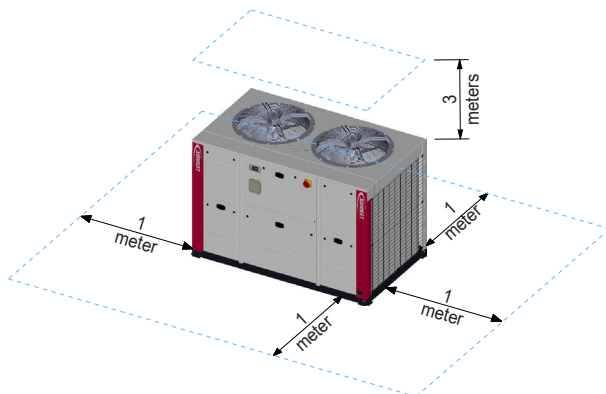

**GAC
030S-110S-125S**

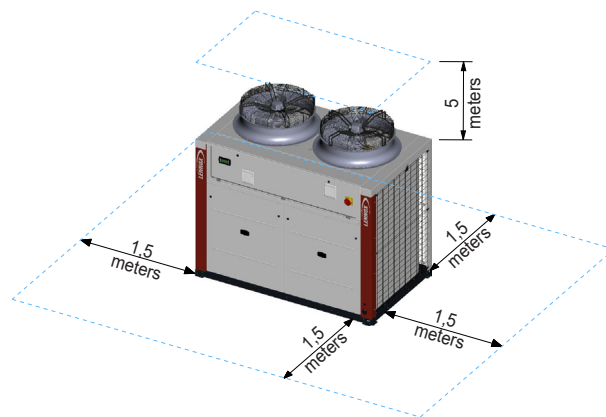
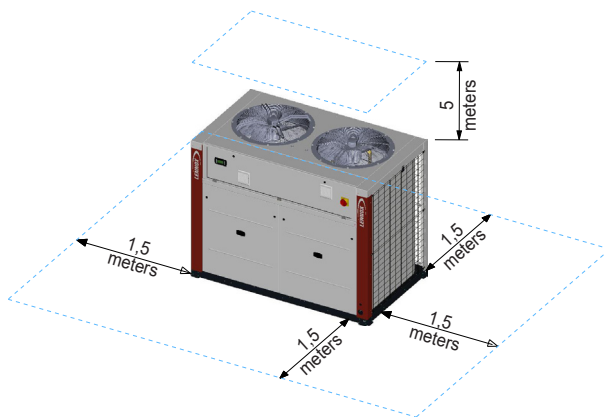

2.- INSTALLATION

2.6.- INSTALLATION CLEARANCES

Clearance around the unit, for any unit version. Keep this space free around the unit for installation.
Failure to install the units as shown will impact performance and reliability.

STANDARD VERSION

UNIT WITH STANDARD EC FANS (SEAS) OR HIGH PRESSURE EC FANS (HIPF)

**GAC 110D-125D GAH
090S-125S**

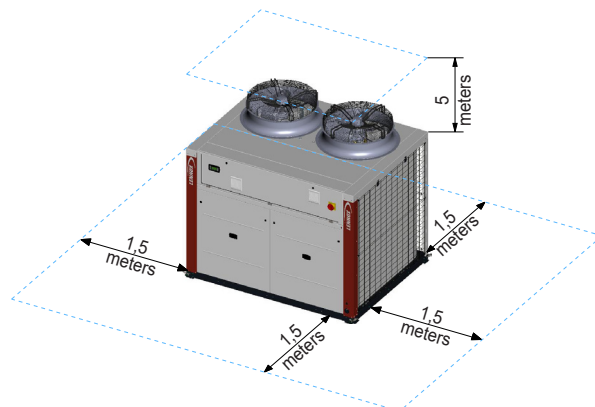
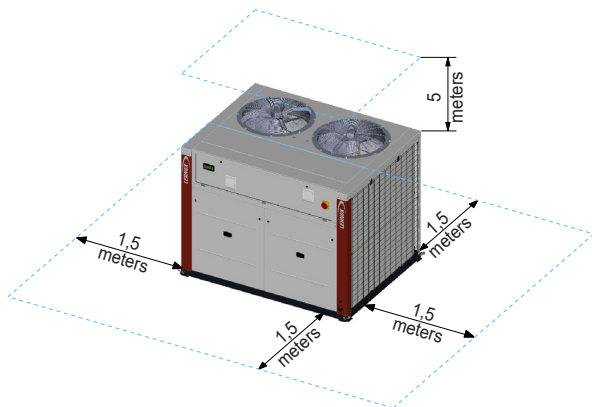

**GAC/GAH
140D**

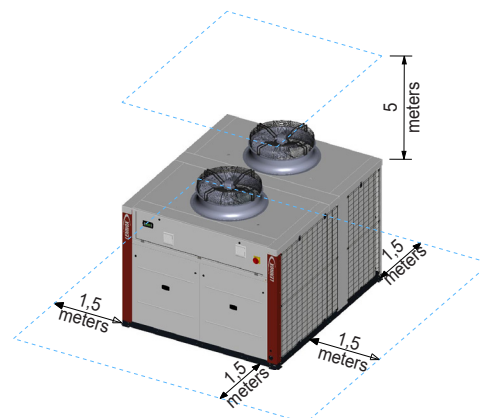
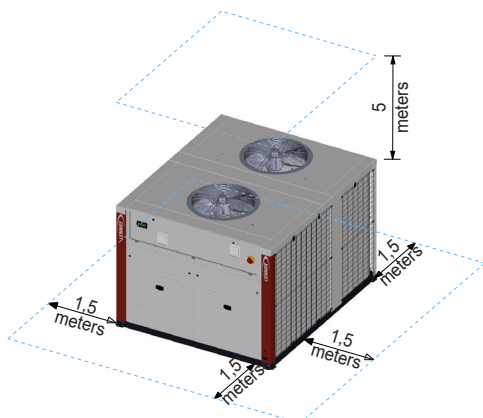

**GAC/GAH
160D-185D**

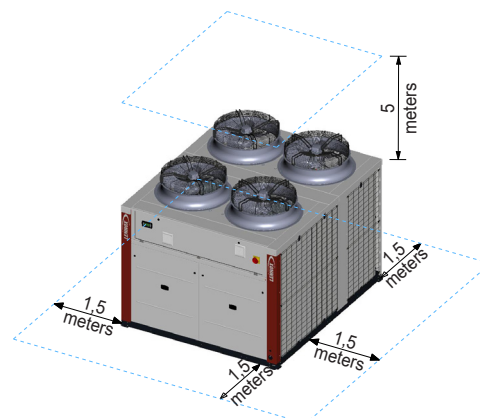
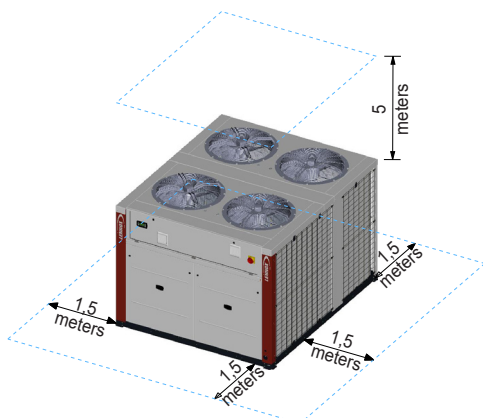

2.- INSTALLATION

2.7.- UNIT INSTALLATION

1. The eComfort units could be installed outside or inside.
2. See the minimum clearance diagrams for access - air supply to the batteries in the heating section of the unit (see page 25).
3. Assemble the unit on a resistant base, preferably concrete. To prevent vibrations, the concrete base should not come into contact with the building's foundations.
4. It is advisable to assemble the unit on shock absorbers (antivibration mountings).
5. During heating mode (heating pump coolers) ice forms in the coils. The defrost process is activated during heating mode in heat pump units, when the outside temperature is low and the outdoor coil could become frozen.

To melt the ice, the defrost function will switch the unit to cooling operation for a short period. When the evaporation temperature starts to drop, a defrost period sets in to provide sufficient heat transfer. During defrosting, the ice melts from the batteries. As a result, the ice contains water which must be removed.

WARNING



If the unit is exposed for long periods to installation conditions below 0°C the water from defrost can freeze in the base of the unit. This prevents drainage. Ice build up can occur preventing correct operation. For these conditions contact customer service team.

6. The heat exchanger water flow during cooling must be the same as during heating.
7. The use of a water filter in the water circuit upstream of the heat exchanger is mandatory. These filters must remove all particles with a diameter greater than 1 mm, and must be positioned within 1 meter of the inlet of the exchanger. They may be supplied as an option by the manufacturer.



LACK OF FILTER AT THE INLET OF A PLATE HEAT EXCHANGER WILL MAKE WARRANTY VOID.

It is important to follow non exhaustive recommendations hereunder:

- The water pipes must not transmit any radial or axial force to the heat exchangers nor any vibration. (Use flexible connections to reduce the transmission of vibrations.)
 - Manual or automatic air bleeders must be installed at all high points in the circuit(s).
 - Drain connections must be installed at all low points to allow the whole circuit to be drained.
 - An expansion device must be installed to maintain pressure in the circuit(s) as well as a safety device
 - Comply with the water inlet and outlet connections shown on the unit.
 - Install thermometers in both the entering and leaving water connections.
 - Install stop valves, close to the entering and leaving water connections.
 - After testing for leaks, insulate all pipe work, to reduce thermal leaks and to prevent condensation.
 - If the external water pipes are in an area, where the ambient temperature is likely to fall below 0°C, insulate the piping and add an electric heater. As an option, the internal unit piping is protected.
 - Ensure full earthing continuity
 - Connection pipes must under no circumstances generate strain on the piping system of our units. To do this, appropriate means of support and fastening must be used.
 - Respect a sufficient number of supports for the piping according to their size and weight under operating conditions and to design the piping to avoid a water hammer phenomenon
8. Use water treating if necessary.
 9. Location inside:

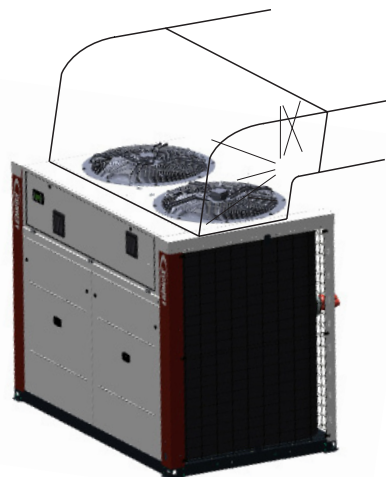
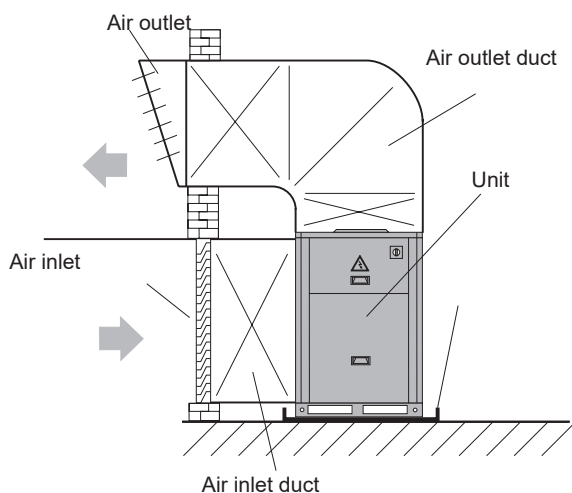

2.- INSTALLATION

For location inside, keep in mind following advice:

- In heat pump units during defrost cycle, the units produce a great amount of water melting the ice off coils.
If you wish to drain the water, adequate drainage should be installed below the unit to collect and carry out the water where desired.
 - Air duct installation:
If air duct has been installed, the operating limits get reduced
10. For cooling or heat pump units the hydraulic system must contain the following components pump, buffer tank, expansion device, safety valve, water filter, flow switch.
 11. To obtain the total water system pressure drop add the unit pressure drop + water pipework + fittings and terminal unit pressure drops the water pump can be selected to provide the correct water flow across the heat exchanger.
 12. A water balancing valve is advised to ensure correct water flow.



IMPORTANT

If the outside temperature in the area where the eComfort unit is to be installed is likely to drop below 5°C, it is very important to take the following precautions to avoid that water in the circuit freezing, that may produce damage to the components.

- If unit has to work under low outside temperatures:

* Do not disconnect power supply in order that water pump starts when detects water temperatures below +5 °C (only Hydraulic and Hydronic models).

* If the outside temperature where the system is to be installed or the water outlet temperature is likely to drop below 5°C, it is very important to use glycol anti-freeze.

The amount of anti-freeze required will vary depending on the minimum ambient temperature or the water outlet temperature.

When the percentage of glycol increases the standard pump flow decreases, the pressure drop increases and the cooling and thermal capacities drop. As a result the minimum flow must be multiplied by the coefficient shown in the table:

Minimum ambient temperature or water outlet temperature	Ethylene Glycol %	Pressure drop	Water flow	Power input	Capacities	
					Cooling mode	Heating mode
From +5°C to 0°C	10%	1,05	1,02	0,997	0,995	0,994
From 0°C to -5°C	20%	1,10	1,05	0,996	0,985	0,993
From -5°C to -10°C	30%	1,15	1,08	0,995	0,975	0,99
From -10°C to -15°C	35%	1,18	1,10	0,994	0,965	0,987

Also is advisable to use the option “evaporator anti freeze protection”

Failure to follow this advice, may result in damage to the installation.

Optionally, an immersion heater can be supplied complete with safety thermostat and pressure switch fitted in the buffer tank of the cooling only chiller. A similar option is available for heat pump versions with the added advantage of a supplementary heating source (Hydronic version units).



Legislation does not allow refrigerant gas emissions to the atmosphere, so the refrigerants have to be recycled to avoid being released to the aosphere.

Those recycled refrigerants shall be processed afterwards by an authorized waste manager. Those components derived from the recycling of the unit have to be managed by authorized waste manager or be left in local waste facilities according the local normative in each country.

2.- INSTALLATION

2.8.-ELECTRICAL CONNECTIONS



- BEFORE MAKING ANY ELECTRICAL CONNECTIONS, BE SURE THAT ALL CIRCUIT BREAKERS ARE OPEN AND SUPPLY IS OFF.
- IN ORDER TO CARRY OUT THE ELECTRICAL CONNECTIONS, FOLLOW THE ELECTRICAL DIAGRAM SUPPLIED WITH THE UNIT.



Before connecting the electric power cables (L1 - L2 - L3), it is imperative to check the correct order of the 3 phases before connecting to the main disconnect switch.
Use proper wire terminal material that is compatible to the type of wire (Copper or Aluminum) being used.
Use proper procedures and coatings when using aluminum wires to avoid galvanic corrosion which may lead to a short circuit event.

Recommended cable selection

The sizing of the power cables is the responsibility of the installer. It must be done in accordance with the electrical values of each unit (noted at the time of ordering, the firm plate and on the electric diagram) and according to the **regulations of each country**.

The table below is given as an indication and does not engage the responsibility of LENNOX.

Once the selection is made, the installer must make the adaptations if necessary.

The connections on the main switch of the unit are to be realized with lugs or bars. In case of use of aluminum wires, the customer must use bi-metal terminals.

- WTHH: Water tank electrical heater.
- The cable sections have been calculated based on.
 - A distance of 50m and variation of -10V.
 - XLPE insulation copper cable over perforated cable tray.
 - Max. T^a: 50°C
 - Type of cable in Cu RV-K.
- Do not start the unit if the drop is greater than this.
- Ground wires must be properly connected and have a greater length than the phase wires.

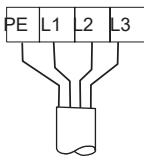
POWER SUPPLY	UNIT MODEL	NUMBER OF WIRE x SECTION			
		COBRE / CUPPER CU		ALUMINIO / ALUMINIUM AL	
		WITHOUT WTHH	WITH WTHH	WITHOUT WTHH	WITH WTHH
 <p>3 ~ 400V-50Hz + PE</p>	20SM2M	4G x 6 mm ²	4G x 6 mm ²	4G x 6 mm ²	4G x 10 mm ²
	25SM2M	4G x 6 mm ²	4G x 10 mm ²	4G x 6 mm ²	4G x 10 mm ²
	30SM2M	4G x 6 mm ²	4G x 10 mm ²	4G x 10 mm ²	4G x 16 mm ²
	35SM2M	4G x 6 mm ²	4G x 10 mm ²	4G x 10 mm ²	4G x 16 mm ²
	40SM2M	4G x 6 mm ²	4G x 16 mm ²	4G x 10 mm ²	4G x 16 mm ²
	45SM2M	4G x 10 mm ²	4G x 16 mm ²	4G x 10 mm ²	4G x 25 mm ²
	55SM2M	4G x 10 mm ²	3 x 25 mm ² 1 x 16 mm ²	4G x 16 mm ²	3 x 35 mm ² 1 x 16 mm ²
	60SM2M	4G x 16 mm ²	3 x 35 mm ² 1 x 16 mm ²	4G x 25 mm ²	3 x 50 mm ² 1 x 25 mm ²
	70SM2M	4G x 16 mm ²	3 x 35 mm ² 1 x 16 mm ²	3 x 35 mm ² 1 x 16 mm ²	3 x 50 mm ² 1 x 25 mm ²
	80SM2M	4G x 25 mm ²	3 x 35 mm ² 1 x 16 mm ²	3 x 35 mm ² 1 x 16 mm ²	3 x 70 mm ² 1 x 25 mm ²
	90SM2M	3 x 25 mm ² 1 x 16 mm ²	3 x 50 mm ² 1 x 25 mm ²	3 x 50 mm ² 1 x 16 mm ²	3 x 95 mm ² 1 x 35 mm ²
	110SM2M	3 x 35 mm ² 1 x 16 mm ²	3 x 70 mm ² 1 x 35 mm ²	3 x 70 mm ² 1 x 25 mm ²	3 x 95 mm ² 1 x 50 mm ²
	125SM2M	3 x 50 mm ² 1 x 16 mm ²	3 x 70 mm ² 1 x 35 mm ²	3 x 70 mm ² 1 x 35 mm ²	3 x 120 mm ² 1 x 50 mm ²
	110DM2M	3 x 35 mm ² 1 x 16 mm ²	3 x 70 mm ² 1 x 35 mm ²	3 x 50 mm ² 1 x 25 mm ²	3 x 95 mm ² 1 x 50 mm ²
	125DM2M	3 x 50 mm ² 1 x 25 mm ²	3 x 70 mm ² 1 x 35 mm ²	3 x 70 mm ² 1 x 35 mm ²	3 x 120 mm ² 1 x 70 mm ²
140DM2M	3 x 70 mm ² 1 x 25 mm ²	3 x 95 mm ² 1 x 50 mm ²	3 x 95 mm ² 1 x 35 mm ²	3 x 150 mm ² 1 x 95 mm ²	
160DM2M	3 x 70 mm ² 1 x 35 mm ²	3 x 120 mm ² 1 x 50 mm ²	3 x 95 mm ² 1 x 50 mm ²	3 x 150 mm ² 1 x 95 mm ²	
185DM2M	3 x 95 mm ² 1 x 35 mm ²	3 x 120 mm ² 1 x 70 mm ²	3 x 120 mm ² 1 x 70 mm ²	3 x 185 mm ² 1 x 95 mm ²	

2.- INSTALLATION

2.8.-ELECTRICAL CONNECTIONS

GAC/GAH 020 - 185

VOLTAGE OPERATION LIMITS

MODELS	VOLTAGE	LIMITS
020-185	3~400V-50Hz ±10%	3~360-440V-50Hz

Main switch pad dimension

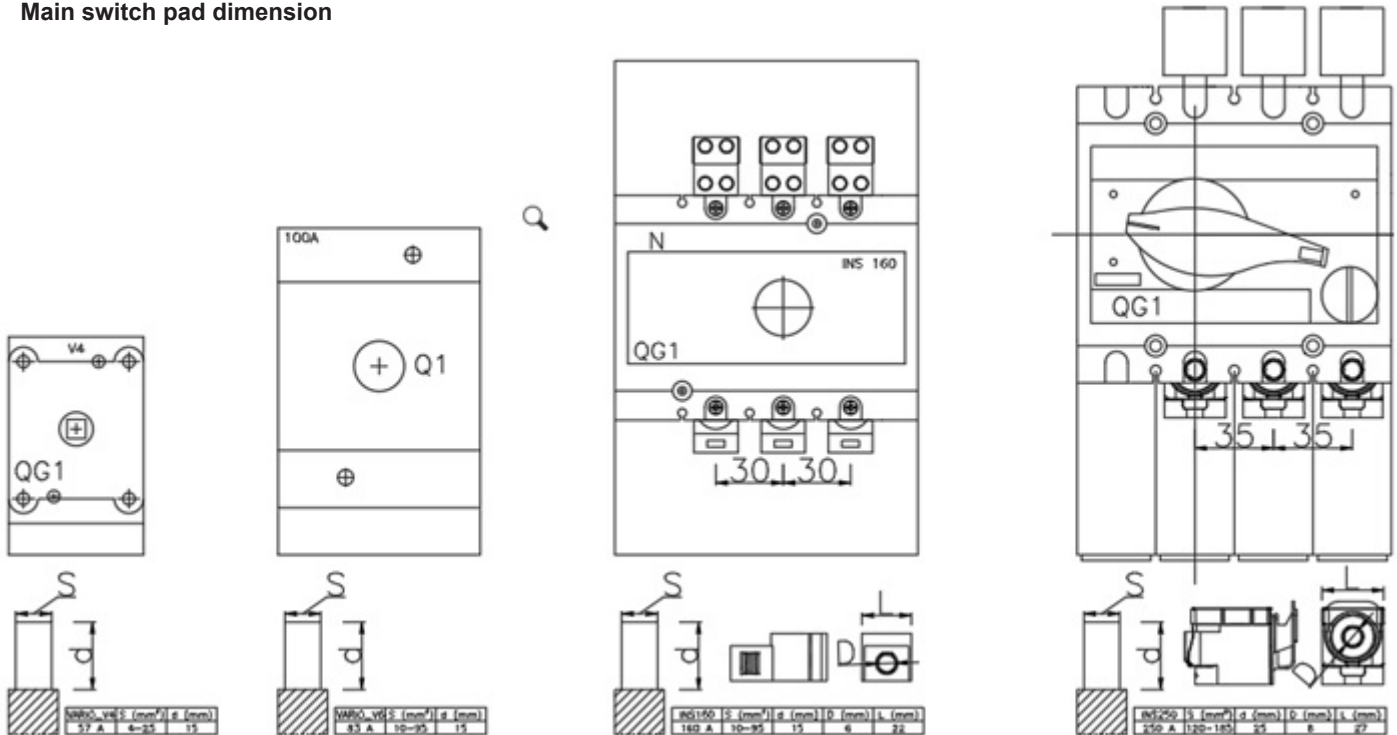

Customer protection information

In order to protect our unit, LENNOX recommends the implementation of this type of protection upstream. There are two options available, either circuit breaker protection or fuse protection.

The customer must provide the necessary equipment in his installation to protect the power line that feeds our unit.

A differential of 300mA is recommended.

If the unit is equipped with variable condenser fans or variable speed pumps or compressor, a type B differential is recommended.

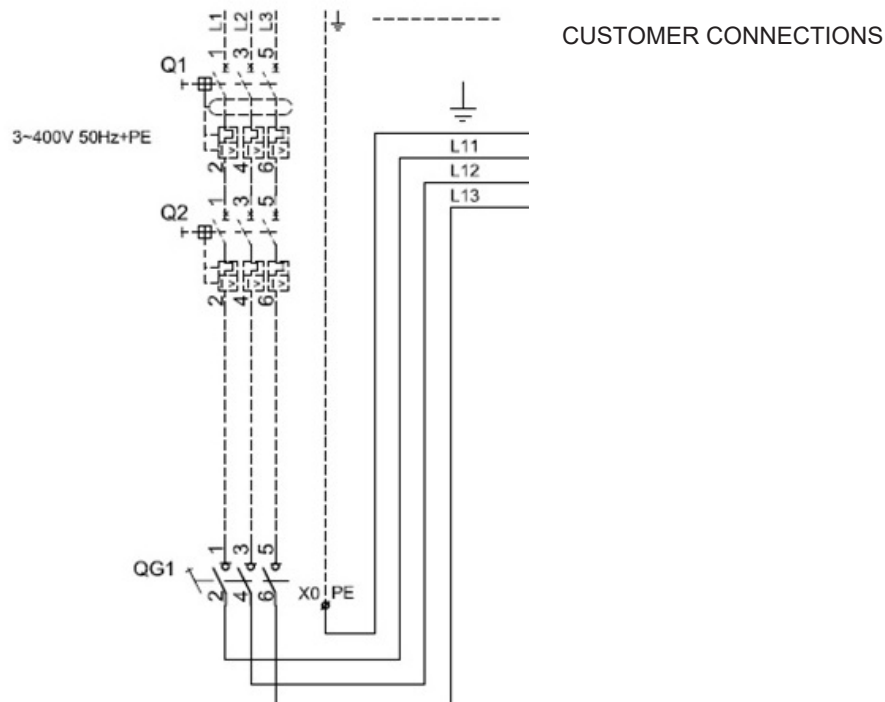

2.- INSTALLATION

2.9 -PARTIAL HEAT RECOVERY OPTION

The aim of the Partial Heat Recovery (PHRF) is to recover temperature heat from the compressor discharge gases by means of a condensing water heat exchanger.

The heat recovery capacity depends on the operating conditions (the compressor discharge temperature comes from the HP/LP ratio), on the number of compressor running, on the water flow and on the water inlet temperature.

The unit will always be driven by the air conditioning load. In any case, if there is no load on the cooling side, the unit will not be able to generate heat. The heat capacity will always be in accordance with the cooling capacity and the absorbed power of the unit.

The simplest regulation we recommend: a 3-way valve with a regulation on the water temperature. All regulation should be managed by the customer

GAC-H 090S-110S-125S

CUSTOMER CONNECTION

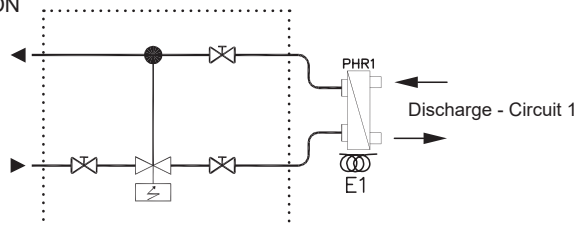

GAC-H 110D-125D-140D-160D-185D

CUSTOMER CONNECTION

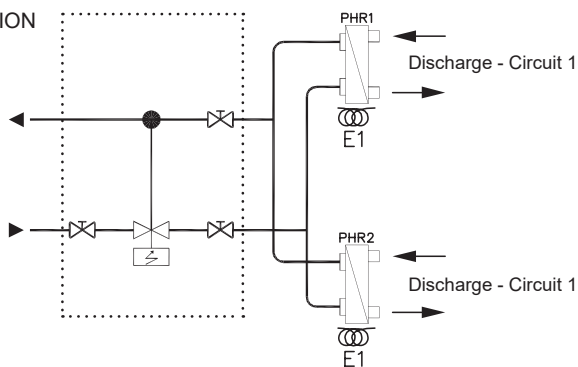

3.- COMMISSIONING AND OPERATION

LENNOX REFAC, S.A. Designs and develops its machines always looking for the greater comfort and well-being of its customers and users, at the same time as the greater energy efficiency of the elements that constitute the units. This effort would be fruitless if it was not united to a responsible use of these equipment. For this reason, we invite you to use these machines in a responsible way with the environment, combining the adequate comfort, with a responsible consumption of the energy resources.

3.1.- STEPS TO FOLLOW FOR COMMISSIONING THE UNITS

Before commissioning the unit check the following:

1. Check that the voltage is the same as the rated voltage on the specification plate.
 2. Check that the supply to the control system is connected in accordance with the electrical diagram (if incorporates)
 3. Make sure that the water connections are correct and have not been altered, as this can result in incorrect operation the flow divider will not operate if the connections are mixe.
 4. Check that the main switch is ON.
 5. The compressor must not be started until the crankcase heater has been running for at least 8 hours.
 6. Check the water pump's direction of rotation.
 7. Check for air in the water system. Purge if necessary.
 8. Check that the fan can rotate freely.
- The compressor has an electric heating element to assure a separation between the Refrigerant and the oil in the housing. This heater is activated when the compressor is off and stops working when the compressor is on. About eight hours before start up or after a long shutdown period, voltage should be supplied to the unit and main switch activated in order to this heater will be activated.
 - Check that the compressor starts after several minutes since water pump is working.
 - Adjust the control to select the operating mode.
 - Water connections: before running the unit for the first time, check that the water circuits are connected to the heat exchangers (for example, no inversion between evaporator and condenser or between the water inlets and outlets. Waer pump will be preferably upstream, so the evaporator/condenser will be under possitive pressure. Water inlet and outlet connections are indicated in the certified scheme sent with the unit or depicted in the manual. A filter must be installed in the water circuit upstream the heat exchanger. This filters must stop all the particles higher than 1 mm in diameter and must be placed at 1 m maximum from the exchanger inlet.



REMEMBER THAT THE COMPRESSOR IS A SCROLL TYPE COMPRESSOR:

Before starting the unit, the compressor should be checked that rotates in the correct direction, through a three phase protection. Scroll type compressors only compress in one direction of the rotation. Therefore, it is essential that the phase connection for scroll-type three-phase compressors be carried out correctly (the correct direction of rotation can be checked when the pressure on the suction side decreases and the pressure on the discharge side increases when the compressor is activated). If the connection is wrong, the rotation will be reversed causing a high noise level and a reduction in the amount of current consumed. If this occurs, the compressor's internal protection system will operate in shutting down the unit. The solution is to disconnect, switch the wires between two of the phases and connect the three again).

- Occasionally, when compressor stops and starts, there is a metallic noise because of spirals of the compressor. This is normal.
- Check compressor oil level, sight glass included (on the sides of the compressor, the level should be between 1/4 and 3/4 in the sight glass, while during operation the level should be between 3/4 and full).
- Check that operating pressure values are normal.
- Measure electrical consumption for the unit.
- Check the electrical consumption of the compressor and the fans with what is specified in the physical data sheets.
- In the case of a Heat Pump unit, make a cycle change checking that the 4-way valve makes the change correctly. Check the pressure values in the new cycle.

3.- COMMISSIONING AND OPERATION

3.2.- STEPS TO FOLLOW FOR CONTROL SETTING

I. SETTINGS

1. Check unit clock settings

2. Scheduling (depend on customer requirements) Zone & Mode (NIGHT, DAY, DAY I, DAY II)

(2138): Number of zone desired

(2141): Start time of zone 0 set to 00h00 to start each day

(2142): Starts time of zone 1 adjustable every day from Monday to Sunday

(2143): Starts time of zone 2 adjustable every day from Monday to Sunday

(2144): Starts time of zone 3 adjustable every day from Monday to Sunday

(2145): Starts time of zone 4 adjustable every day from Monday to Sunday

(2146): Starts time of zone 5 adjustable every day from Monday to Sunday

(2147): Starts time of zone 6 adjustable every day from Monday to Sunday

(2139): Number of mode desired

(2141): Mode linked to the zone 0 adjustable every day from Monday to Sunday

(2142): Mode linked to the zone 1 adjustable every day from Monday to Sunday

(2143): Mode linked to the zone 2 adjustable every day from Monday to Sunday

(2144): Mode linked to the zone 3 adjustable every day from Monday to Sunday

(2145): Mode linked to the zone 4 adjustable every day from Monday to Sunday

(2146): Mode linked to the zone 5 adjustable every day from Monday to Sunday

(2147): Mode linked to the zone 6 adjustable every day from Monday to Sunday

3. Set point per mode

(2113), (3113): Schedule on/off

(3431): Enable of the compressor(s) on circuit 1

(3432): Enable of the compressor(s) on circuit 2

(2236): Outside air temperature corresponding to the water evaporator set point (2238)

(2237): Outside air temperature corresponding to the water evaporator set point (2239)

(2238): Water temperature set point corresponding to the outside air temperature (2236)

(2239): Water temperature set point corresponding to the outside air temperature (2237)

(2246): Outside air temperature corresponding to the water evaporator set point (2248)

(2247): Outside air temperature corresponding to the water evaporator set point (2249)

(2248): Water temperature set point corresponding to the outside air temperature (2246)

(2249): Water temperature set point corresponding to the outside air temperature (2247)

(3341): Pump evaporator mode (P1on, P1Auto, P2on, P2Auto, P1P2on, P1P2AUTO)

(3541): Condensing fan control mode (Auto, AutoQuiet, Quiet)

(3542): Sound level (dBa)

4. Regulation water temperature (if no scheduling configured)

Cooling mode :

(2236): Outside air temperature corresponding to the water evaporator set point (2238)

(2237): Outside air temperature corresponding to the water evaporator set point (2239)

(2238): Water temperature set point corresponding to the outside air temperature (2236)

(2239): Water temperature set point corresponding to the outside air temperature (2237)

Heating mode :

(2246): Outside air temperature corresponding to the water evaporator set point (2248)

(2247): Outside air temperature corresponding to the water evaporator set point (2249)

(2248): Water temperature set point corresponding to the outside air temperature (2246)

(2249): Water temperature set point corresponding to the outside air temperature (2247)

5. Changeover mode (only for heat pump)

(2224): Changeover mode for each schedule mode (NIGHT, DAY, DAY I, DAY II, and BMS).

6. Pump mode :

(3343) : Fix, Delta T, Delta P, P.out, Flow

3.- COMMISSIONING AND OPERATION

3.2.- STEPS TO FOLLOW FOR CONTROL SETTING

7. Remote control connection (on/off, cool/heat, alarm)

- (3141): BM-ID3 digital input configuration setting
- (3142): BM-ID4 digital input configuration setting
- (3131): BM-NO1 output relay configuration setting

8. BMS configuration (address, baud rate)

- (3825): Watchdog for activation of the BMS mode
- (3826): BMS address
- (3827): BMS protocol
- (3828): BMS baud rate
- (3829): BMS Modbus RTU format

II. Test

- Check electrical connections
 - (power supply & phase order)
 - External connexions (customer inputs/relays/displays)
 - Check the thermal protection of the circuit brakers. Watch out the Condenser fans circuit breaker protection will be 2xImax
- Check water filter & hydraulic connections
- Open the unit and check inside
- Power-up the unit

1. Evaporator pump

- (3114)= 'Pump Evap' (1 or 2 in case of double pump)
 - Check the flow switch status in the menu (2218)
 - Check the electrical consumptions (in case of variable pump in the pump technical service screen pressing PRG)
 - Check the evaporator DP in menus
 - After this test, check flow switch opens

2. Condenser fan

- (3114)= 'C*.Fan.LS' (low speed)
- (3114)= 'C*.Fan.HS' (high speed)
- (3114)= 'C*.100%' (modulating speed)
 - Check the electrical consumptions (in case of EC fan in the fan technical service screen pressing PRG)

3. Frigorific circuit test

Cooling mode

- (3114)= 'C1.Cool'
- Check the circuit pressures and temperatures
- Check the electrical consumptions

(3114)= 'C2.Cool'

- Check the circuit pressures and temperatures
- Check the electrical consumptions

Heating mode

- (3114)= 'C*.Heat'
- Check the circuit pressures and temperatures
- Check the electrical consumptions

4. HP cut off

(3114)= 'HP Cut-Off C*'

5. Electrical auxiliary heater

- (3114)= 'Auxiliary heater'
- Check the inlet / outlet temperatures
- Check the electrical consumptions

6. Electrical antifreeze heater

- (3114)= 'Antifreeze heater'
- Check the control voltage on the TRIAC (10vdc)

3.- COMMISSIONING AND OPERATION

3.3.- CHECKING THE WATER FLOW RATE

It is very important that the unit operates at the correct water flow rate. It is dangerous to leave the unit operating at a low flow rate as this could result in serious damage to components as well as the water exchanger. If the unit operates at too high a flow rate, this will also hinder optimum performance. The best way of determining the operating flow rate is to measure the temperature difference between the inlet and water outlet.

Checking the water flow rate (it is vital to measure the thermal peak) (Standard unit)

For nominal and minimum water flow the difference between the inlet and water outlet temperature should be 5°C (cooling and heating pump units in cooling cycle only) for an inlet temperature of 12°C, an outlet temperature of 7°C and an outside temperature of 35°C. If these conditions change, the unit capacity will also change and as a result for nominal flow the difference between the inlet and water outlet temperature will vary slightly from 5°C as can be seen in the following table, based on nominal flow rate.

Water outlet °C	ΔT (Water inlet temperature - Water outlet temperature)						
	Outside temperature (°C)						
	15	20	25	30	35	40	45
7	6,1	5,8	5,5	5,3	5,0	4,7	4,4
9	6,5	6,2	5,9	5,6	5,3	5,0	4,7
11	7,0	6,7	6,4	6,0	5,7	5,4	5,0

If the unit must be started in the heating cycle and if you wish to operate at nominal cooling rate, the following shows the approximate differences between the inlet and water outlet temperatures for the various conditions.

Water outlet °C	ΔT (Water inlet temperature - Water outlet temperature)				
	Outside Temperature (°C BH)				
	-6	0	6	12	18
35	4,5	5,5	6,5	7,5	8,5
50	4	5	6	7	8

Note:

The unit control system displays the inlet and water outlet temperature to be displayed. See the Control Description section.

Check that the correct water pump has been selected, taking into account the loss of pressure in the hydraulic system. It is dangerous to let the unit run at a low rate and any faults which may result will not be covered under warranty.

Do not start up the air conditioning units or the fan coils until the water temperature reaches the set temperature or use an automatic control device which cancels the air conditioning unit operation if the installation is not properly set.

When everything is operating normally, take a reading of all the data and **fill out the Commissioning Sheet**.

3.- COMMISSIONING AND OPERATION

3.4.- WATER ANALYSIS

The water must be analysed; the water circuit installed must include all items necessary for treatment of the water: filters, additives, intermediate exchangers, bleed valves, vents, isolating valves etc... depending on the results of the water analysis.

We do not advise operation of the units with open loops which can cause problems with oxygenation, or operation with untreated ground water.

Use of untreated or improperly treated water can cause deposits of scale, algae and sludge or cause corrosion and erosion. It is advisable to call in a qualified water treatment specialist to determine what kind of treatment will be necessary. The manufacturer cannot accept liability for damage caused by the use of untreated or improperly treated water, salt water or brine.

Here are our non exhaustive recommendations given as an indication:

- No NH_4^+ ammonium ions in the water, they are very detrimental for copper. $<10\text{mg/l}$
- Cl^- Chloride ions are detrimental for copper with a risk of perforations by corrosion by puncture. $< 10 \text{ mg/l}$.
- SO_4^{2-} sulphate ions can cause perforating corrosion. $< 30 \text{ mg/l}$.
- No fluoride ions ($<0.1 \text{ mg/l}$).
- No Fe^{2+} and Fe^{3+} ions with dissolved oxygen. Dissolved iron $< 5 \text{ mg/l}$ with dissolved oxygen $< 5 \text{ mg/l}$. Over those values, it means a corrosion of steel which may generate a corrosion of copper parts under deposit of Fe – this is mainly the case with shell and tube heat exchangers.
- Dissolved silicon: silicon is an acid element of water and can also lead to corrosion risks. Content $< 1\text{mg/l}$.
- Water hardness: TH $>2.8 \text{ K}$. Values between 10 and 25 can be recommended. This will facilitate scale deposit that can limit corrosion of copper. TH values that are too high can cause piping blockage over time.
- TAC < 100 .
- Dissolved oxygen: Any sudden change in water oxygenation conditions must be avoided. It is as detrimental to deoxygenate the water by mixing it with inert gas as it is to over-oxygenate it by mixing it with pure oxygen. The disturbance of the oxygenation conditions encourages destabilisation of copper hydroxides and enlargement of particles.
- Specific resistance – electric conductivity: the higher the specific resistance, the slower the corrosion tendency. Values above 3000 Ohm/cm are desirable. A neutral environment favours maximum specific resistance values. For electric conductivity values in the order of $200\text{-}6000 \text{ S/cm}$ can be recommended.
- pH: pH neutral at 20°C ($7 < \text{pH} < 8$)

4.- MAINTENANCE

When carrying out maintenance works on these units, please make a correct segregation of the non-hazardous waste generated: insulation, air filters, plastic or metallic elements, packaging, etc., as well as waste considered hazardous: oils, filters and rags impregnated with oils, welding elements such as filler material, strippers, electrical and electronic waste, batteries, lamps, etc., these must be managed by an authorized dealer.

The refrigerant gas can be reused, or collected in a bottle and managed as hazardous waste by an authorized dealer.

4.1.- PREVENTIVE MAINTENANCE



PREVENTIVE MAINTENANCE PREVENTS COSTLY REPAIRS.

We recommend regular and thorough servicing of the LENNOX unit. It is therefore advisable to ask your dealer about maintenance contracts. Check maintenance of the following points (depending on the operating conditions maintenance every 6 months may be necessary).

Local legislation always takes precedence.

GENERAL STATE OF THE CASING:

Casing, paint, deterioration due to bumps, rust spots, leveling and supporting, state of the antivibration mounts, if installed, screwed panels, etc.

ELECTRICAL CONNECTIONS:

State of cables, tightness of screws, grounding, current draw of the compressor and fans and checking that the unit is receiving the correct voltage.

REFRIGERANT CIRCUIT:

Check that pressure values are correct and that there are no leaks. Check that there is no damage to the pipe insulation, that the state of the batteries is correct and that there are no chips or clogs retained by the air flow, etc.

COMPRESSOR:

Inspect the oil level.

Inspect the state of the compressor mountings.

FANS:

Check that fans turn freely and in the correct direction without excessive noises.

CONTROL:

Check Set Points and normal operation.

WATER:

If the installation contains anti-freeze, regularly check the state of the anti-freeze as well as the cleanliness of the water.

WATER FILTER:

Clean the water inlet filter if necessary.

WATER PUMP:

When the installation is going to work with percentages of glycol up to 20% and water temperatures below -5°C, even do we use a specific closing for the water pump, it is advisable to clean the water pump's closing every year and a half, in order to avoid leaks by crystallization.

PLATE EXCHANGER:

Prove the general isolation state and tightness of the water connections.

CHECK FOR REFRIGERANT LEAKAGE AND WATER LEAKAGE.

4.- MAINTENANCE

4.2.- MAINTENANCE PLAN

N°	MAINTENANCE PLAN		Monthly	+ Quarterly	Half Yearly
	Task	Operating mode			
1	Inspection of the microchannel coils aluminum-copper connexions for corrosion	Inspection to be realised when cleaning the coils. If corrosion is detected, a preventive treatment needs to be done following our recommendations			
2	Cleaning the coils (In accordance with local regulations)	It's mandatory to clean the external coils, according to the environment where the unit is located, the frequency of the cleaning varies from once in a month to minimum twice in a year. The performance and the sustainability of the machine is based on the perfect heat exchange. The use of a neutral pH cleaning product is mandatory (WARNING: Fins and copper tubes are very fragile! Any damage WILL reduce the performances of the unit).			
3	Inspection of compressors electrical intensities	Check the electrical intensity of each compressor on the 3 phases of partial load and at 100% - with a certain frequency, according to the utilization of the machine. Example : Monthly : If the unit is used all over the year Half Year : if seasonal use			
4	Electrical cabinets air-filters cleaning	Based on the environment of the installation, it's mandatory to clean the filters from once a month to twice a year. To avoid overheating the electrical components. Check the filter fouling rate, clean or replace it when needed by an original filter	•	•	•
5	Inspection of the condensers fans	Check the rotation of the fan (free rotation, detection of vibrations or bearing noises) Check for the Amps consumed on all three phases; compare it with the nominal value given in the electrical wiring diagram. Check the status of the fan blades and its protections.			
6	Visual inspection of the oil level and check the oil for traces of acidity in the refrigerant circuits	Visually check the oil level through the sight glass on the side of the compressor casing. Test the oil every 3 years and after each intervention on the refrigerant circuit			
7	Check the 4-way valve	When in cooling mode, change it to HeatPump mode. Reset the control.			
8	Check the position of the crankcase heaters (around the compressor) and it's the proper operation	Check the right fixation of the crankcase heaters , if it is tight enough And verify the crankcase heaters overall working.			
9	Verification of the defrost cycle with 4-way valve inversion.	Switch the unit to heat pump mode. Change the set point to obtain the standard defrost mode and reduce the cycle time to the min value. Check the operation of the defrost cycle.			
10	Check the water pressure in the circuit if it's possible	Check the water pressure in the circuit and the efficiency of the expansion vessel		•	
11	Check overall working of the flow controller	Cut-off the compressors, stop the water circulation. Then start the unit and wait for the water flow failing signal in the controller.			
12	Check the circulation pumps	Check the absorbed electrical intensity and the correct rotation of the pumps. Check the water-tightness of the pump mechanical seal and if needed follow the manufacturer maintenance plan.			

N°	MAINTENANCE PLAN		Monthly	+ Quarterly	Half Yearly
	Task	Operating mode			
13	Check water flow	Measure the water flow rate and compare to the selected initial value from the order			
14	Inspection and cleaning the water filter	ATTENTION : The water circuit can be under pressure. Follow the usual precautions when depressurizing the circuit before opening. Ignoring this rules can lead to accidents and cause injury to the personal.			
15	Check the watertightness of the unit and it's accessories	Verify the gaskets, if cracked or ripped, repair them or replace them.			
16	Check CLIMATIC™ control, set-points and variables	Refer to the commissioning sheet; Check all set points are set according to this document.			
17	Check refrigeration system for proper functioning (Thermal expansion valve)	Retrieve/Check the values of overheating and subcooling. Resume the expansion valve settings when needed and verify the behavior in partial loads and at 100%. Resume settings to obtain overheating between 5K and 10K			
18	Check refrigeration system for proper functioning (Electronic expansion valve)	Retrieve/Check the values of the pressure and temperature sensors. Check also the good behavior of the expansion valve (Open/closed) in full load and partial load. The overheated must be between 5K and 8K.			
19	Check the position and tightness of refrigeration components	Check systematically all connections and fixings on the refrigeration circuit. Check for oil traces, eventually a leak test should be conducted. Check operating pressures correspond to the ones indicated on the commissioning sheet.			
20	SIGHT GLASS (when applicable)	The liquid refrigerant flow through the sight glass should be steady and without bubbles. Bubbles are a sign of a low charge, a possible leak, or of a restriction in the liquid line. Each sight glass is fitted with a humidity indicator. The color of the element changes according to the level of humidity in the refrigerant, but also according to temperature. It should indicate «dry refrigerant. If it shows «wet» or «CAUTION», contact a qualified refrigeration technician. CAUTION: when starting up the unit, run the compressor for at least 2 hours before taking a humidity reading. The humidity detector is also sensitive to temperature, and as a consequence, the system must be at normal operating temperature to give a meaningful reading.			
21	Check antifreeze protection	Test antifreeze function (leakage rate, frost protection thermostat)			
22	Check refrigeration 3-way valve	Check the proper functioning of the system.			
23	Check tightness of all electrical connections	Power down the unit and check and tighten all screws, terminal and electric connections (including the terminal boxes) When turning on the unit, check the deterioration of the electrical components with a thermal camera, with the unit working at 100% of it's power.			
24	Check HP / LP safety switches	Install a pressure gauge HP / LP and check if the safety switches overall working.			

N°	MAINTENANCE PLAN		Monthly	+ Quarterly	Half Yearly
	Task	Operating mode			
25	Check the value of the analogue sensors	Install the pressure gauge calibrated to check the analogue sensors . Install a thermometer calibrated to control the sensors.			
26	Check the position of all sensors	Check the good positioning and the fixation of all sensors.			•
27	Check anti-vibration mountings, for wear and tear.	Visually check anti-vibration mountings on compressors and centrifugal fan. Replace if damaged.			•
28	Check Glycol concentration in the water circuit	Check the glycol concentration in the pressurized water circuit. (a concentration of 30% gives a protection down to approx.. -15°C) Check the circuit pressure			
29	Check casing and equipment corrosion	To treat and neutralize eventuals rust spots			•
30	Check the watertightness of the unit and it's accessories	Verify the gaskets, if cracked or ripped, repair them or replace them.			•
31	Check the watertightness of the water circuit	Check for water leaks and repair if it's needed.			•
32	Check the water pump	When the installation is going to work with percentages of glycol up to 20% and water temperatures below -5°C, even do we use a specific closing for the water pump, it is advisable to clean the water pump's closing every year and a half, in order to avoid leaks by crystallization.			
33	Plate exchanger	Prove the general isolation state and tightness of the water connection and the freeze protection.			
34	Check the expansion vessel if appropriate	Measure the pressure under the different water modes (from +7°C to +45°C)			
35	Check the software version	Contact the manufacturer for updates			

4.- MAINTENANCE

4 3- CLEANING THE CONDENSER

4.3.1 - Air cooled condensers

Clean the coils either with a vacuum cleaner, cold water, compressed air, or with a soft brush (non metallic). On units installed in a corrosive atmosphere, coil cleaning should be part of the regular maintenance program. On this type of installation, all dust gathered on the coils should be quickly removed by regular cleaning.

Caution: Except for NEOSYS range with MCHx coils, do not use high pressure cleaners that could cause permanent damage to the aluminium coil fins.

Specific maintenance of microchannels exchangers connection



For microchannel heat exchangers, the coil connexion to the circuit is made by means of a solder copper / aluminum. This connection is protected from galvanic corrosion by a special resin encapsulated in a heat-shrinkable sheath.

This sleeve must be regularly visually inspected during unit cleaning operations to detect a possible premature deterioration.



Good shape



Bad shape

Indeed with slightly corrosive atmospheres, a small copper etching can lead to a loss of adhesion of the resin thus allowing moisture to seep under the sleeve while triggering galvanic corrosion phenomena between the aluminum and the Copper.

If this attack is not detected in time, a leak may appear and then force change of the exchanger.



Galvanic corrosion under the plastic sleeve.



A LEAKAGE BY CORROSION DUE TO A LACK OF CONDENSER MAINTENANCE IS NOT COVERED BY UNIT WARRANTY

In case of deterioration of the sleeve, it must be removed and replaced by polyurethane sealant - like Sikaflex 221 or equivalent. In this case the recommended procedure is as follows :

4.- MAINTENANCE

4 3- CLEANING THE CONDENSER

Step 1

Remove the damaged sleeve by operating a longitudinal section as in the photo below :



Step 2

Clean the connection with a wire brush and a synthetic abrasive as one can find on the back of kitchen sponges :



Step 3

Clean and dry the connector with paper towels and acetone to remove any grease or surface pollution.

Step 4

Apply polyurethane sealant – like Sikaflex 221 - with a pistol and then spread it over the entire surface to be covered with a brush :



Feel free to add some polyurethane sealant to ensure complete coverage of the area.

4.3.2 - Plate heat exchanger condensers

Use a non corrosive solvent to remove scale deposits. The equipment to be used for external water circulation, the quantity of solvent and the safety measures to be taken must be approved by the company supplying the cleaning products or by the company conducting these operations.

4 4- PROCESS FOR REPLACING A COMPRESSOR ON THE FIELD

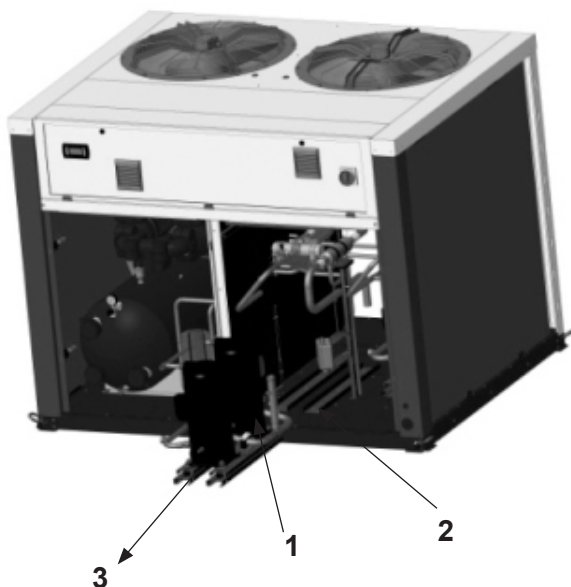

1. Unweld discharge and suction line
2. Unscrew the rails compressor support
3. Slide the rails of compressors out of the unit
4. Replace the compressor
5. Slide again the rails inside the unit and fix the rails

4.- MAINTENANCE

4.5.- CORRECTIVE MAINTENANCE



IMPORTANT MAKE SURE THAT THE UNIT IS COMPLETELY DISCONNECTED FROM THE POWER SUPPLY WHEN CARRYING OUT ANY TYPE OF WORK ON THE MACHINE

If some component in the cooling circuit must be replaced, follow these recommendations:

- Always use original replacement parts.
- Regulation prohibits the release on the refrigerant into the atmosphere.
- If cuts must be made in the pipe work, use pipe cutters. Do not use saws or any other tools that produce filings.
- All brazing must be carried out in a nitrogen atmosphere to prevent corrosion from forming.
- Use silver alloy brazing rod.
- Take special care that the flame from the torch is aimed in the opposite direction from the component to be welded and is covered with a wet rag in order to avoid overheating.

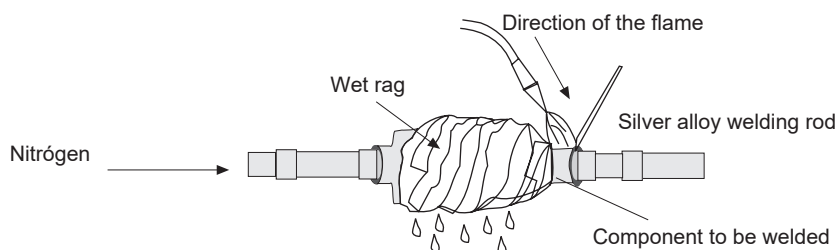

- Take very special care if 4-way check valves are to be replaced since these have internal components that are very heat-sensitive such as plastic, teflon, etc.
- If a compressor must be replaced, disconnect it electrically and un-braze the suction and discharge lines. Remove the securing screws and replace the old compressor with the new one. Check that the new compressor has the correct oil charge, screw it to the base and connect the lines and electrical connections.
- Carry out the vacuum above and below through the Schrader valves of the outdoor unit until -750 mm Hg is reached. Once this level of vacuum has been reached, keep the pump in operation for at least one hour. **DO NOT USE THE COMPRESSOR AS A VACUUM PUMP.** If the compressor runs in vacuum it will fail.
- Charge the unit with refrigerant according to the data on the Rating Plate for the unit and check that there are no leaks.



PRECAUTIONS TO BE TAKEN IN THE USE OF R-410A REFRIGERANT

The following precautions characteristic of this gas should be taken:

- The Vacuum Pump must have a Check Valve or Solenoid Valve.
- Pressure Gauges and Hoses for the exclusive use with R-410A Refrigerant should be used.
- The charge should be carried out in the Liquid Phase.
- Always use scales to weight-in charge
- Use the Leak Detector exclusive for R-410AC Refrigerant.
- Do not use mineral oil, only synthetic oil to ream, expand or make connections.
- Keep pipes capped before using them and be very thorough about any possible moisture and dirt (dust, filings, burrs, etc.).
- Brazing should always be carried out in a nitrogen atmosphere.
- Reamers should always be well sharpened.
- The refrigerant bottle must contain at least 2 % of the total amount.
- All the components derived from the recycling of the unit should be managed according local legislation, and have to be classified and separated while dealt by authorized waste manager or be left in local waste facilities.
- Refrigerant fluids, electronic boards, heat exchangers and the oil extracted from the refrigerant circuit, as well as the oil recipients used must be recycled as hazardous waste according the local normative through an authorized waste manager or be left in local waste facilities. The rest of the components considered as non-hazardous wastes must be recycled according to the corresponding norms.
- At the end of its life, the equipment should be recycled in local waste facilities or by an authorized waste manager.

4. MAINTENANCE

4.6.- FAILURE DIAGNOSIS

PROBLEM	CAUSE	ACTION
The unit does not start after the last start.	<ul style="list-style-type: none"> • Disconnected supply. • Main switch set to STOP. • No water flow. • Fuses are broken. • Low electrical supply. • One of the safety devices has been activated. • Compressor fault. • Low water temperature. 	<ul style="list-style-type: none"> • Check electrical supply. • Connect main switch. • Start water pump (and check air in system). • Check voltage. • Check antifreeze thermostat. • Check high/low pressure switch. • Change compressor. • Create demand for cooling.
The fan does not work (although the compressor is operating).	<ul style="list-style-type: none"> • Internal safety device open. • Bad connection. • Poor condensation control. 	<ul style="list-style-type: none"> • Let the motor cool. • Connect properly. • Check operation.
The compressor stops when the high pressure switch is cut off.	<ul style="list-style-type: none"> • Condenser coil blocked. • Unit operating outside of limiting. • Abnormal operation of the fans. 	<ul style="list-style-type: none"> • Maintain condenser coil. • Check the ventilators.
The compressor stops when the low pressure switch is cut off.	<ul style="list-style-type: none"> * Insufficient charge. * The water exchanger is blocked (water side). * No water flow. * Expansion valve blocked 	<ul style="list-style-type: none"> * Check the charge. * Maintain the exchanger. * Check that there is sufficient water flow. * Change expansion valve.
The oil level in the compressor is very low.	<ul style="list-style-type: none"> • The crank case heater is not working. 	<ul style="list-style-type: none"> • Replace the crank case heater and check oil level.
High noise level of compressor and high and low pressures are abnormal.	<ul style="list-style-type: none"> • Phase connection for compressor power supply incorrectly. 	<ul style="list-style-type: none"> • Switch the wires between two of the phases of compressor power supply.

5. RISK ANALYSIS AND HAZARDOUS SITUATIONS ACCORDING TO PED DIRECTIVE

N°	Event	Effect	Risk	Actions to Eliminate the Risk	Information to minimise the occurrence of a risk
1A	Violent Chocks, Static or Dynamic Loads applied	Appearance of cracks, distortions, possibility of rupture	Leaks, liquid or gas projections, Metal parts projections.	Only handling the units using the chassis and lifting rings if available.	Handling procedure shown in the IOM supplied with the unit.
2A	Unit not installed properly or leveled to the ground	Unusual stress in the frame leading to possible and strains vibrations and cracks	Leaks	Level the machine during commissioning. In the case where the unit is installed on anti-vibration mountings, all supporting points must be used and the block hardness must be selected according to the type of units being installed.	Indications on general mechanical drawings in the technical guide and the IOM supplied with the unit.
3A	Unsuited hydraulic or refrigeration pipe- work	Unusual stress on the pipe-work leading to possible and strains vibrations and cracks	Leaks	Proper support and fitting of the pipe-work on site.	Indications in the technical IOM supplied with the unit.
4A	Outdoor temperature below freezing	Strains, vibrations and cracks, pipe bursting.	Partial or complete destruction of the circuit, liquid/ gas could be thrown out of the unit	Provide anti-frost protection (ei: Water treated with Glycol, or trace heaters along the pipe-work)	Indications in the technical IOM supplied with the unit.
5A	Circuits exposed to an unusual heat source.	Modification of the mechanical properties of certain materials with a risk or rupture or pipe bursting, leaks or cracks appearing.	Partial or complete destruction of the circuit, liquid/ gas could be thrown out of the unit	Recommended minimum and maximum outdoor temperature– 20°C to 50°C during operation.	Indications of the Min and Max outdoor temperature on the unit nameplate
				–30°C to 50°C during storage Do not expose any part of the machine to a naked flame	
6A	Unusual increase in the temperature of the Chilled water return to the evaporator or the hot return water to the condenser	Increase of the refrigerant pressure in the heat exchanger with risk of exceeding the working pressure leading to possible strains, vibrations, cracks and pipe or vessel bursting.	Partial or complete destruction of the circuit, liquid/gas/ metal parts could be thrown out of the unit	Maximum chilled water return temperature: 45°C	Indications in the technical IOM supplied with the unit.
				Maximum hot return water temperature: 50°C	
				Install a temperature limitation device	
7A	Possibility of a unit being hit by lightning	Extreme heat, explosion, cracks.	Partial or complete destruction of the circuit, liquid/gas/ metal parts could be thrown out of the unit	Provide an appropriate protection against lightning.	Indications in the technical IOM supplied

5. RISK ANALYSIS AND HAZARDOUS SITUATIONS ACCORDING TO PED DIRECTIVE

N°	Event	Effect	Risk	Actions to Eliminate the Risk	Information to minimise the occurrence of a risk
8A	Unit exposed to extremely corrosive materials.	Modification of the mechanical and chemical properties of certain materials with a risk or corrosion rupture, pipe bursting, leaks and cracks.	Partial or complete destruction of the circuit, liquid/gas/ metal parts could be thrown out of the unit	Protect the units against these types of products	Indications in the technical IOM supplied
9A	Unit exposed to explosive materials.	Risk of explosion or pipe bursting.	Partial or complete destruction of the circuit, liquid/gas/ metal parts could be thrown out of the unit	Protect the units against these types of products	Indications in the technical IOM supplied
10A	Inappropriate Heat Transfer Fluid	Corrosion, excessive heat	Partial or complete destruction of the circuit. Leaks	Usual fluids are Water or Water with Glycol.	Indications in the technical IOM supplied
11A	Inappropriate refrigerant fluid in the circuit	Corrosion, excessive heat, combustion or explosion	Partial or complete destruction of the circuit, liquid/gas/ metal parts could be thrown out of the unit	Only use the fluid specified on the unit's nameplate.	Indications of the refrigerant fluid on the unit nameplate
12A	Inappropriate oil in the compressor	Corrosion, excessive heat,	Partial or complete destruction of the circuit. Leaks	Authorized oils: Refer to the compressor nameplate or the documentation.	Indication on the compressor nameplate or the manufacturer documentation.
13A	Working on a part under pressure	Risk of explosion or part bursting away from the machine.	Liquid/gas/metal parts could be thrown out of the unit	Isolate the section of the circuit to be worked on and recover the refrigerant before any work. Always wear protection goggles and gloves.	Indications in the technical IOM supplied
14A	Brazing or un-brazing parts from the circuit	Strains, cracks, pipe bursting	Partial or complete destruction of the circuit, liquid/gas/ metal parts could be thrown out of the unit	Parts to be brazed using best engineering practices. Use brazing materials approved by LENNOX. Ensure the circuit is leak free before refilling with refrigerant.	Indications in the technical IOM supplied
15A	Unit exposed to inductive interferences	Corrosions, cracks	leaks	Ensure the unit is earthed properly	Indications in the technical IOM supplied
16A	Unit exposed to internal or external vibrations	Strains, cracks, explosions	Partial or complete destruction of the circuit, liquid/gas/ metal parts could be thrown out of the unit	Inspect the unit regularly	Indications in the technical IOM supplied

6. END OF THE MACHINE LIFE

At the end of the useful life of the units, please take into account the correct segregation of the waste generated. No Hazardous like: Painted metallic parts, plastic elements, copper pipes, batteries, exchangers, liquid receivers, water pumps, fans.. And Hazardous Materials such as batteries, electrical and electronic elements, compressors, dehydrating filters, valves or refrigerant gas, etc. to be managed with an authorized dealer.

SALES OFFICES :

BELGIUM AND LUXEMBOURG

 + 32 3 633 3045

FRANCE

 +33 1 64 76 23 23

GERMANY

 +49 (0) 211 950 79 60

ITALY

 + 39 02 495 26 200

NETHERLANDS

 + 31 332 471 800

POLAND

 +48 22 58 48 610

PORTUGAL

 +351 229 066 050

SPAIN

 +34 915 401 810

UKRAINE

 +38 044 585 59 10

UNITED KINGDOM AND IRELAND

 +44 1604 669 100

OTHER COUNTRIES :

LENNOX DISTRIBUTION

 +33 4 72 23 20 20



Due to LENNOX EMEA ongoing commitment to quality, the specifications, ratings and dimensions are subject to change without notice and without incurring liability. Improper installation, adjustment, alteration, service or maintenance can cause property damage or personal injury. Installation and service must be performed by a qualified installer and servicing agency.



www.lennoxemea.com

MIL160E-0720 07-2020

